

T6 - Centrally Connected & VONOPLAN T6.

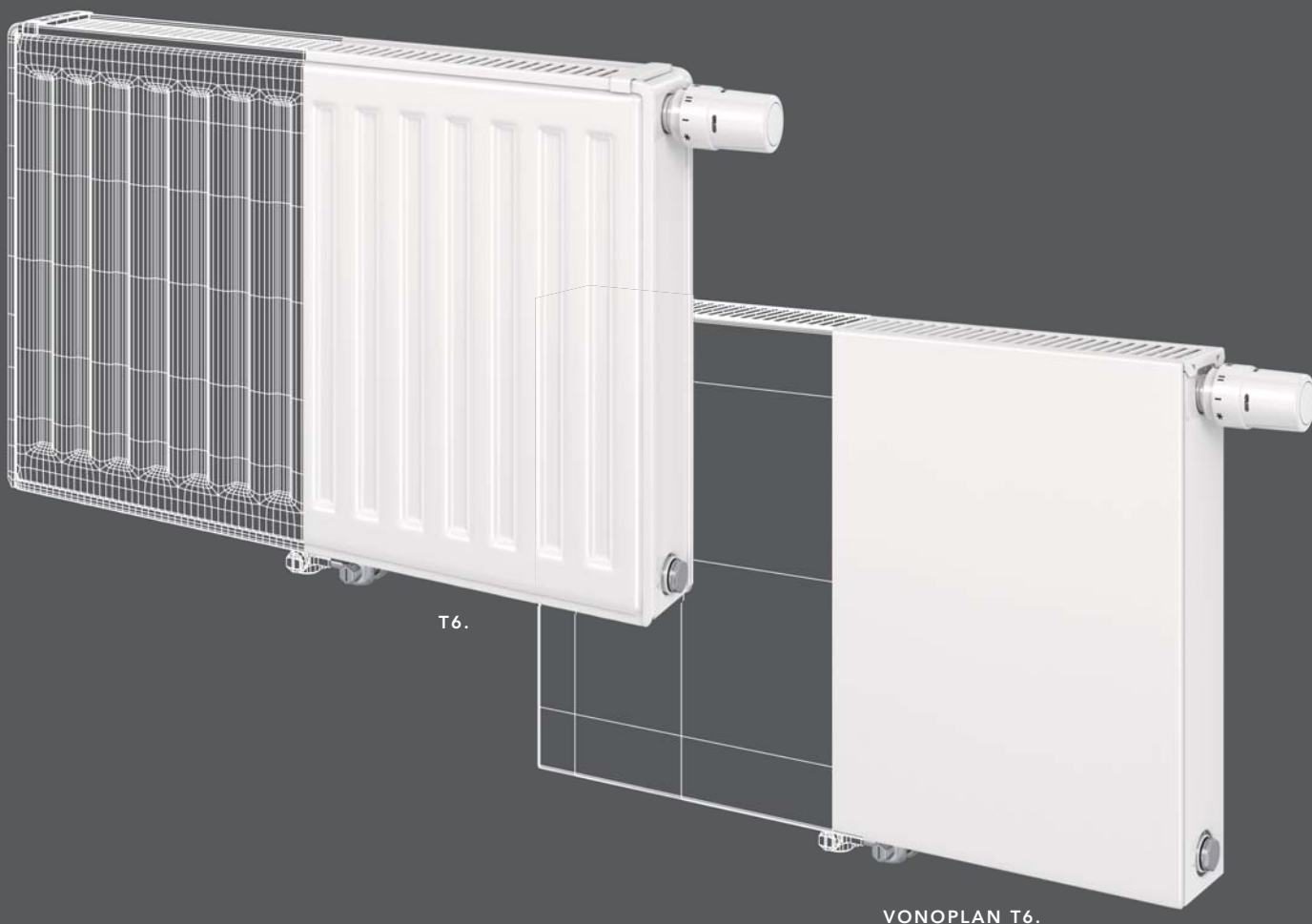

T6.

VONOPLAN T6.

General Specifications

Approval and Certification

VOGEL&NOOT offers strong products that meet the highest quality standards during manufacture and operation. All information on the quality and performance of **VOGEL&NOOT** panel radiators is verified and confirmed by recognised European institutions on an ongoing basis, thereby guaranteeing the highest level of heating performance and optimum product quality.



When used in systems designed and installed in accordance with the good practice recommendations given in the 'Application' section, the **VOGEL&NOOT T6** centrally connected and **VONOPLAN T6** radiators carry a ten year guarantee from date of purchase against defects caused by faulty materials or manufacture. However, failure to pay attention to these recommendations (in new or existing systems) may invalidate the manufacturer's warranty.

Material and Paint Finish

T6 centrally connected and **VONOPLAN T6** radiators are subjected to a thorough painting process involving degreasing, phosphating and primer coating (stoved) prior to the final finishing coat of white semi-gloss epoxy paint, which is cured at 210°C. Colour options are available, see pages 38 & 39, for a small extra charge and with a 6-8 week delivery lead time. This means that **T6** centrally connected and **VONOPLAN T6** radiators can be installed without further painting, although if desired (e.g. colour change), overpainting can be carried out using a good quality, oil-based gloss paint. Additionally, white touch-up paint is available.

T6 centrally connected radiators are made of cold-rolled sheet steel, and in accordance with EN 442-1, with stylish and robust waterways at 40 mm intervals. **VONOPLAN T6** has a galvanised front panel (1mm thick).

Packaging

All our radiators are individually wrapped in heavy duty polythene shrink-wrapping and are clearly marked externally with type and size. The radiator panels are also wrapped in cardboard and all corners are further protected with preformed caps.

The packaging is designed to enable full fitting and assembly of radiators into the heating system, without removal of the protective packaging - a real plus point for new building installations. Radiators left protected in this way can be filled and run up to 40°C during initial cleaning and commissioning of the heating system.

Fixings

Each **T6** centrally connected and **VONOPLAN T6** radiator is equipped with an integrated valve insert set and is suitable for double-pipe and single-pipe systems with a single-pipe manifold. Each radiator is supplied with a fitted valve top with a pre-set k_v -value. A range of thermostatic heads can be fitted directly to the built in valve by removing the protective cap. All radiators are supplied with welded suspension brackets on the back, drain plug, pivoting special vent plug and the dummy plug which are all fitted with seals. All types of radiator are equipped with a detachable top cover and two closed side panels.

For the correct installation of radiators it is essential that the fixing of the radiator is carried out in such a way that it is suitable for intended use AND predictable misuse. A number of elements need to be taken into consideration including the fixing method used to secure the radiator to the wall, the type and condition of the wall itself, and any additional potential forces or weights that may happen to be applied to the radiator, prior to finalising installation.

Accessories

Accessories are available for the **T6** centrally connected and **VONOPLAN T6** radiators. Please visit www.vogelandnoot.co.uk or call for more information.

Connections

All **T6** centrally connected and **VONOPLAN T6** radiators are fitted with 4 x 1/2" BSP connections and 2 x external thread 3/4" BSP bottom centre connections.

Our valve radiators' connections (external thread 3/4" BSP) comply in construction and tolerance with the specifications, in accordance with DIN V 3838. If conically sealed drain cocks are used (single-pipe operation), where an adjustment of tolerance of distance to the centre is not possible, we must repudiate liability for any damage connected to this.

Therefore we recommend to use only flat sealed drain cocks, or drain cocks where an adjustment of tolerance of the distance to the centre is possible.

Operating Pressures

Every **T6** centrally connected and **VONOPLAN T6** radiator is tested to a pressure of 13 bar (189 psi) and is suitable for a working pressure of up to 10 bar (145 psi). They also have a maximum operating temperature of 110°C. With single-pipe installations, a cycle's maximum radiator power of about 10kW at $T = T_1 - T_2 = 20 \text{ K}$ (at $T_1 = 90^\circ\text{C}$) has to be taken into account.

12 T6 - Centrally Connected & VONOPLAN T6

General Specifications

General Specifications (continued...)

Application

T6 centrally connected and **VONOPLAN T6** radiators are for use in indirect or closed circuit heating systems only, which have been properly designed and installed in accordance with the recommendations of BS 5449. In open-vented systems, special attention should be paid to the correct location of the pump in relation to the cold feed and vent pipe connections, to avoid ingress of air or water discharge through the open vent.

All installation work should be carried out in accordance with recognised good practice to ensure long life. In particular, careful attention should be paid to the following:

- Soldered joints should be made with a minimum amount of solder and flux. Choose a flux which is readily soluble in water.
- Copper pipes should be cut and cleaned in such a way as to avoid small copper particles being left in the system (this can lead to electrolytic action and eventual corrosion in the radiator).
- Corrosion inhibitors should be used strictly in accordance with the manufacturer's instructions.

Individual installation instructions are supplied in each radiator package.

Safety Precautions

Radiators are hot when in use, and as such, present a risk of burns to users on prolonged contact. The temperature of a radiator is dependent on the temperature of the system water, as set by the system installer or user. Installers and users should ensure that those who may come into close proximity to hot radiators are aware of the risk of burns. Installers and users should take all necessary steps to minimise the risks of burns. If the risk is significant, consideration should be given to installing low surface temperature radiators, or to placing guards in front of the radiators.

Heat Output

The **T6** centrally connected and **VONOPLAN T6** radiators have an advanced design giving high efficiency characteristics. The high outputs per unit surface area for the convector models have been achieved by ensuring excellent contact between the convector plates and both the water channels and dividing metal of the radiator panels. The convector surface is spot-welded to the metal channels and fits neatly into grooves on the water channels, thus ensuring high heat transfer rates.

The radiator outputs quoted in this brochure are based on a mean water temperature in the radiator of 70°C (158°F) and a room temperature of 20° (68°F) - Delta T50.

For other operating conditions - i.e. differences between mean water temperature and room temperature other than 50°C - the correction factors in the following table should be applied (see example right).

Centigrade	Factor	Fahrenheit
15°C	0.21	27°F
20°C	0.30	36°F
25°C	0.41	45°F
30°C	0.51	54°F
35°C	0.63	63°F
40°C	0.75	72°F
45°C	0.87	81°F
50°C	1.00	90°F
55°C	1.13	99°F
60°C	1.27	108°F
65°C	1.41	117°F
70°C	1.55	126°F

An example of radiator selection at a non-standard temperature difference is given below:

Example:

Heat emission required: 2000 Watts
Room air temperature required: 20°C
Mean water temperature in radiator: 65°C

1. Temperature difference = 65-20 = 45°C
2. From Factor Table 45°C gives a factor of: 0.87
3. Divide required heat emission by factor = $\frac{2000}{0.87}$ = 2298 Watts
4. From selection tables choose any radiator rated at 2298 Watts or more.

Distinguished by the ECO seal of quality



The panel radiators from **VOGEL&NOOT** bear the ECO seal of quality, which stands for all-round compatibility with all (renewable) energy sources. It guarantees that the radiators can be operated in an economical and ecologically-sound manner, with significant savings on heating costs (an average of 15%*) and an enormous reduction in CO₂ emissions.

*On average, in comparison with old sectional radiators, test results based on data from Pinkafeld University of Applied Sciences.

Model Overview

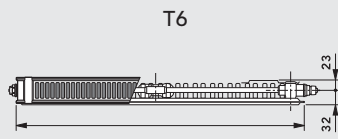

Length

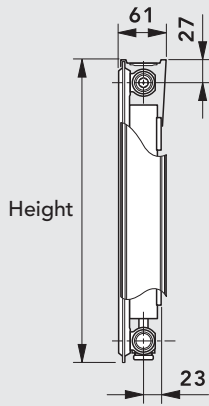

Height

VONOPLAN T6

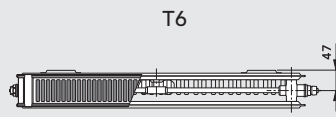
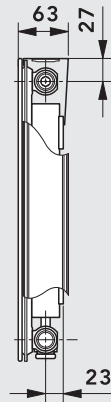
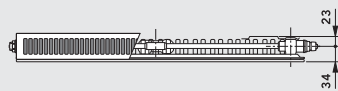

T6

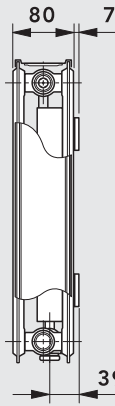

VONOPLAN T6

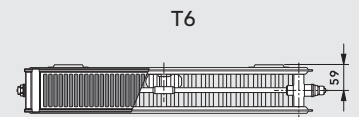
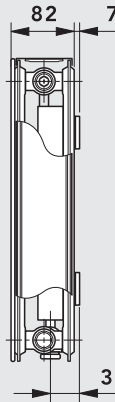

T6

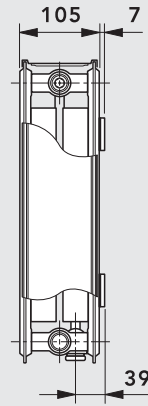

VONOPLAN T6

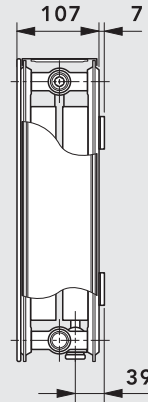
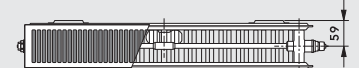

		K1SPG (Single Panel, Single Convector with Factory Fitted Top Grille and Side Panels)				P+ (Double Panel, Single Convector with Factory Fitted Top Grille and Side Panels)		K2 (Double Panel, Double Convector with Factory Fitted Top Grille and Side Panels)			
T6	Height (mm)	300	400	500*	600*	600*		300	400*	500*	600*
	Length (mm)	up to 2000				up to 2000		up to 2000			
VONOPLAN T6	Height (mm)	300	400	500*	600*	600*		300	400*	500*	600*
	Length (mm)	up to 2000				up to 2000		up to 2000			

Steps All lengths start at 400mm and are in increments of 200mm. *Also available in some lengths of 520, 720, 920, 1120 and 1320mm.

14 T6 - Centrally Connected & VONOPLAN T6

Technical Information

Weight and Water Content per Metre Length

Type	Height (mm)							
	300		400		500		600	
	Water Content (l)	Weight (kg)	Water Content (l)	Weight (kg)	Water Content (l)	Weight (kg)	Water Content (l)	Weight (kg)
K1SPG	2.00	0.95	2.60	1.28	3.30	1.46	3.70	1.63
P+	N/A	N/A	N/A	N/A	N/A	N/A	7.10	2.71
K2	3.90	1.79	5.00	2.46	6.10	2.82	7.10	3.16

Mounting Positions, Dimensions and Wall Brackets

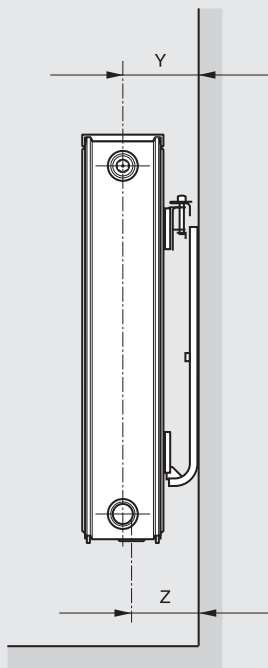

T6 & VONOPLAN T6

Type	Nominal Height (mm)	Y (mm)	Z (mm)
K1SPG	300 - 600	50	50
P+	300 - 600	74	66
K2	300 - 600	86	66

Y = Wall to side connection.

Z = Wall to centre bottom connection.

Wall Bracket for 300mm high

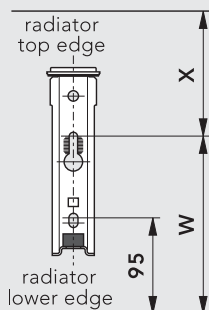

Wall Bracket for 400 - 600mm high

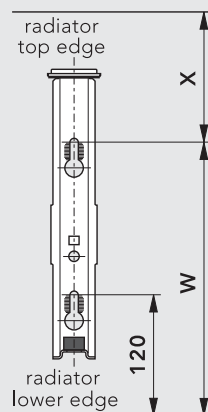

Nominal Height (mm)	W (mm)	X (mm)
300	175	125
400	271	129
500	371	129
600	471	129

Installation

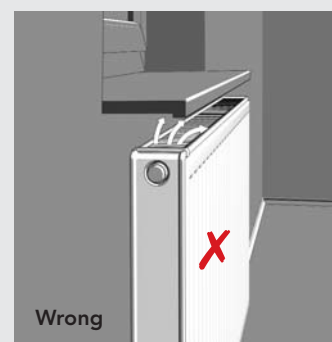
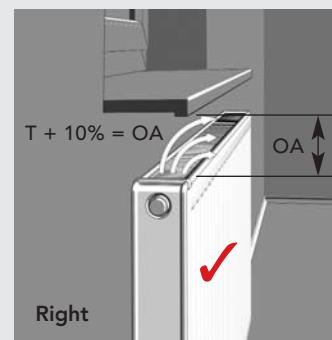

Bracket Positions and Dimensions

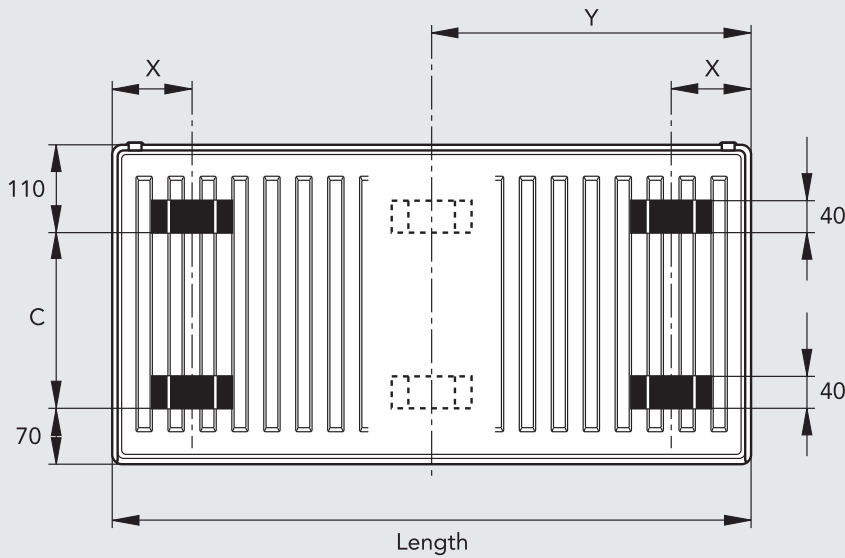

Type	X (mm)
K1SPG	93
P+	100
K2	100

Nominal Height (mm)	C (mm)
300	120
400	220
500	320
600	420

$$\text{Dimension Y} = \frac{\text{Overall Length}}{2}$$

For all radiators with an overall length of 1800mm and above.

Connection Modes - Double-pipe System

A: Single-sided connection

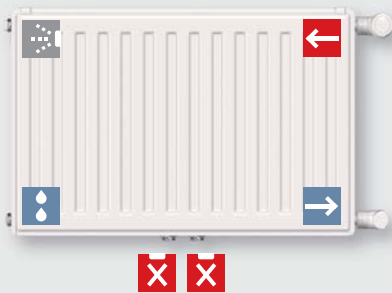

B: Connection both sides

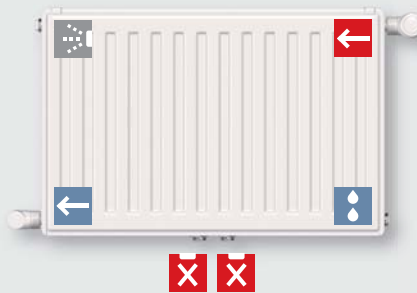

C: Connection on bottom

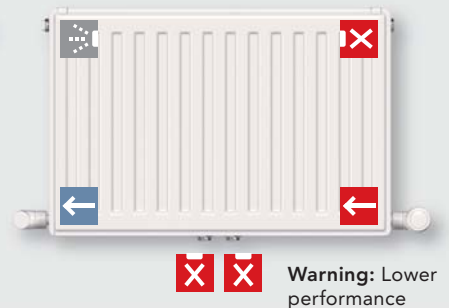

Caution: When using the T6 & VONOPLAN T6 radiator as a compact radiator, the 3/4" plastic screwing caps must be replaced by 3/4" chrome caps (accessory code: BPC). The plastic part of the special vent plug also has to be removed. Further information on double and single pipe operation is provided on pages 16 - 17.

Double-pipe Operation - Adjustment Tips for Built-in Valve

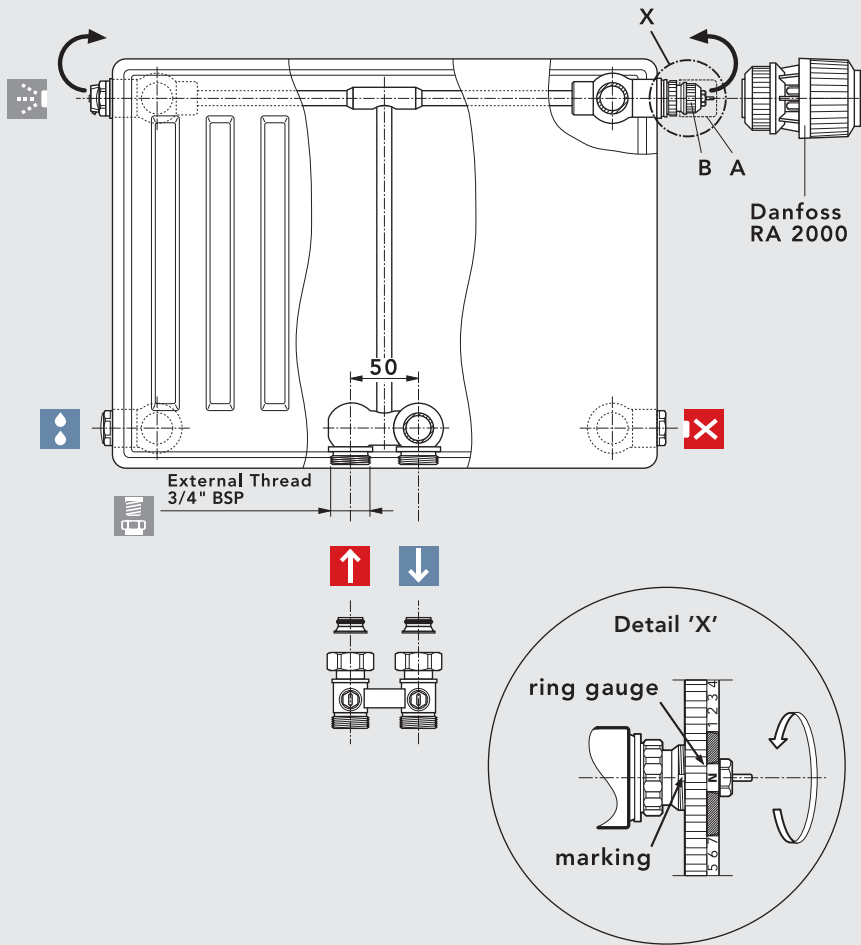

Setting instructions:

VOGEL&NOOT valve radiators are factory-fitted for double-pipe installations. Each individual radiator is fitted with a pre-adjusted valve insert, appropriate to the radiator output. The pre-set k_v -value is also marked in colour on the front surface.

Please note:

Should customised adjustments be required, the pre-set k_v -values can be altered as necessary.

Swapping the right-hand side built-in valve to the left-hand side is a simple operation at any time.

Radiators are delivered with protective caps. After removing the protective cap (position A) the following thermostat heads can be fitted directly to the built-in valve (position B): "RA 2000", "RAW" by Danfoss, "VK" by Heimeier, "D" by Herz, "thera DA" by MNG and "UNI XD" by Oventrop.



The Advantages of Hydraulic Calibration

- Up to 6% energy saving
- CO₂ reduction
- Increased comfort
- Complies with Energy-Efficiency regulations

A system without hydraulic calibration

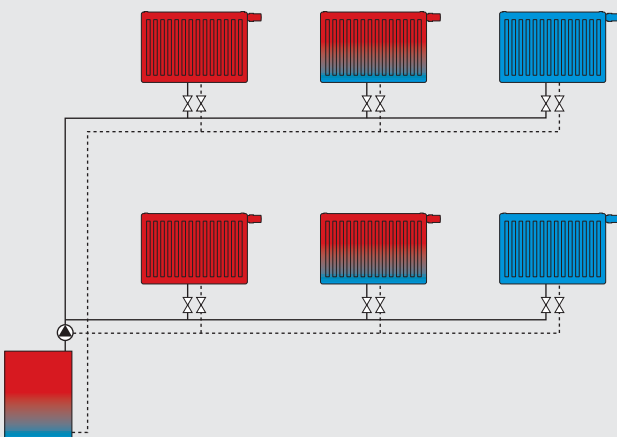

A system with hydraulic calibration

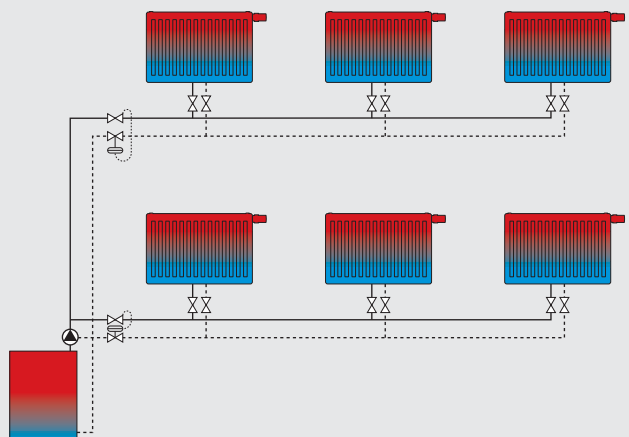

Single-pipe Operation - Factory-adjusted Built-in Valve

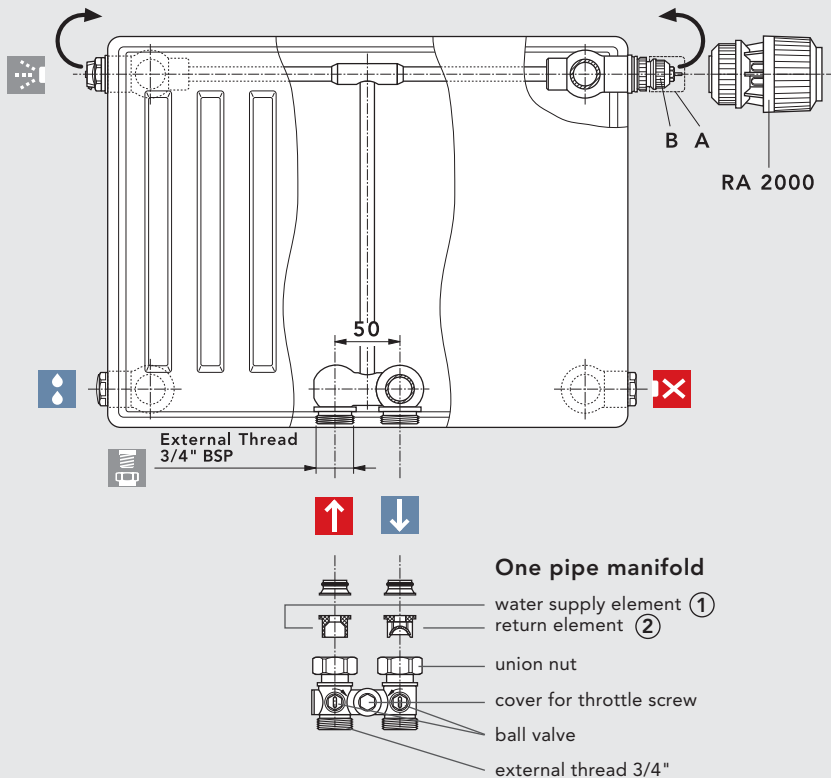

The radiator will be delivered with a protective cap. After removing the protective cap (position A) the following thermostat heads can be installed directly onto the built-in valve (position B): "RA 2000" and "RAW" by Danfoss, "VK" by Heimeier, "theraDA" by MNG, as well as "UNI XD" by Oventrop.

Caution:

During installation, take care that the return element ② has been installed at the water return and the supply element ① at the water supply.

Changing the built-in valve from the right-hand side to the left-hand side is an easy operation at any time.

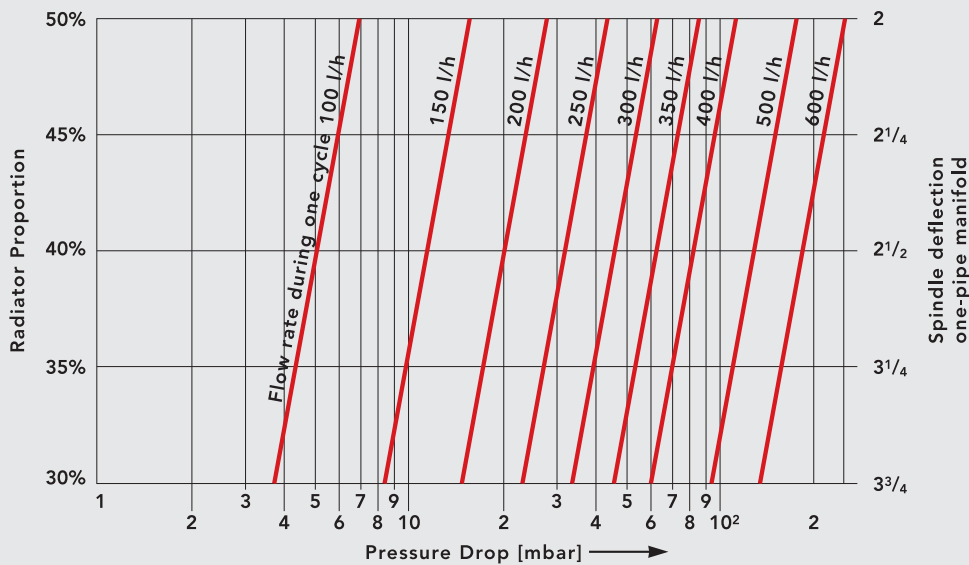

Chart 2
 Pressure drop (mbar) - single-pipe operation with a proportional deviation of 2K.

Default Setting:

- radiator proportion 30%: 3.75 revolutions *
- radiator proportion 35%: 3.25 revolutions *
- radiator proportion 40%: 2.50 revolutions *
- radiator proportion 45%: 2.25 revolutions *
- radiator proportion 50%: 2.00 revolutions *

*when starting, turn the bypass spindle of the one-pipe manifold **to the right** as far as it will go.

It is also possible to change the pre-adjusted valve setting when the equipment is operating at pressure.

Please take into account the maximum power per cycle (regarding single-pipe installations) of about 10 kW
 $\Delta T = T_1 - T_2 = 20 \text{ K}$ (at $T_1 = 90^\circ\text{C}$).

18 T6 - Centrally Connected & VONOPLAN T6

Heat Outputs

T6 - Centrally Connected Heat Outputs

K1SPG

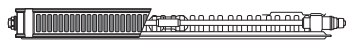

P+



K2



Nominal Height	Nominal Length (mm - inches)	K1SPG			P+			K2		
		Output (watts)	Output (Btu/h)	Order Code	Output (watts)	Output (Btu/h)	Order Code	Output (watts)	Output (Btu/h)	Order Code
300 mm - 12 in	600 - 23.6	339	1157	H11 030 060				657	2242	H22 030 060
	1000 - 39.4	565	1928	H11 030 100				1095	3736	H22 030 100
	1400 - 55.1	791	2699	H11 030 140				1533	5231	H22 030 140
	2000 - 78.7	1130	3856	H11 030 200				2190	7473	H22 030 200

400 mm - 16 in	400 - 15.7	283	966	H11 040 040				543	1852	H22 040 040
	600 - 23.6	425	1449	H11 040 060				814	2778	H22 040 060
	800 - 31.5	566	1933	H11 040 080				1086	3704	H22 040 080
	920 - 36.2							1248	4260	H22 040 092
	1000 - 39.4	708	2416	H11 040 100				1357	4630	H22 040 100
	1200 - 47.2	850	2899	H11 040 120				1628	5556	H22 040 120
	1400 - 55.1	991	3382	H11 040 140				1900	6482	H22 040 140
	1600 - 63.0	1133	3865	H11 040 160				2171	7408	H22 040 160
	1800 - 70.9	1274	4348	H11 040 180				2443	8334	H22 040 180
	2000 - 78.7	1416	4832	H11 040 200				2714	9261	H22 040 200

500 mm - 20 in	400 - 15.7	337	1151	H11 050 040				617	2106	H22 050 040
	520 - 20.4	438	1496	H11 050 052				802	2738	H22 050 052
	600 - 23.6	506	1726	H11 050 060				926	3159	H22 050 060
	720 - 28.3	607	2071	H11 050 072				1111	3791	H22 050 072
	800 - 31.5	674	2301	H11 050 080				1234	4212	H22 050 080
	920 - 36.2	776	2646	H11 050 092				1420	4844	H22 050 092
	1000 - 39.4	843	2876	H11 050 100				1543	5265	H22 050 100
	1200 - 47.2	1012	3452	H11 050 120				1852	6318	H22 050 120
	1400 - 55.1	1180	4027	H11 050 140				2160	7371	H22 050 140
	1600 - 63.0	1349	4602	H11 050 160				2469	8424	H22 050 160
	1800 - 70.9	1517	5178	H11 050 180				2777	9477	H22 050 180
	2000 - 78.7	1686	5753	H11 050 200				3086	10530	H22 050 200

600 mm - 24 in	400 - 15.7	376	1282	H11 060 040	543	1852	H21 060 040	685	2338	H22 060 040
	520 - 20.4	488	1666	H11 060 052	706	2408	H21 060 052	891	3039	H22 060 052
	600 - 23.6	563	1922	H11 060 060	814	2778	H21 060 060	1028	3507	H22 060 060
	720 - 28.3	676	2307	H11 060 072	977	3334	H21 060 072	1233	4208	H22 060 072
	800 - 31.5	751	2563	H11 060 080	1086	3704	H21 060 080	1370	4676	H22 060 080
	920 - 36.2	864	2948	H11 060 092	1248	4260	H21 060 092	1576	5377	H22 060 092
	1000 - 39.4	939	3204	H11 060 100	1357	4630	H21 060 100	1713	5845	H22 060 100
	1120 - 44.1	1052	3588	H11 060 112				1919	6546	H22 060 112
	1200 - 47.2	1127	3845	H11 060 120	1628	5556	H21 060 120	2056	7014	H22 060 120
	1400 - 55.1	1315	4486	H11 060 140	1900	6482	H21 060 140	2398	8183	H22 060 140
	1600 - 63.0	1502	5126	H11 060 160	2171	7408	H21 060 160	2741	9352	H22 060 160
	1800 - 70.9	1690	5767	H11 060 180	2443	8334	H21 060 180	3083	10521	H22 060 180
	2000 - 78.7	1878	6408	H11 060 200	2714	9261	H21 060 200	3426	11690	H22 060 200

N.B. The tabulated heat outputs are quoted at a mean water to air temperature difference of 50°C.

VONOPLAN T6 Heat Outputs

K1SPG



P+

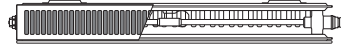

K2



Nominal Height 300 mm - 12 in	Nominal Length (mm - inches)	Output (watts)	Output (Btu/h)	Order Code	Output (watts)	Output (Btu/h)	Order Code	Output (watts)	Output (Btu/h)	Order Code
	600 - 23.6		319	1089	K11 030 060				643	2192
1000 - 39.4		532	1815	K11 030 100				1071	3654	K22 030 100
1400 - 55.1		745	2541	K11 030 140				1499	5116	K22 030 140
2000 - 78.7		1064	3630	K11 030 200				2142	7308	K22 030 200

Nominal Height 400 mm - 16 in	400 - 15.7	264	901	K11 040 040				534	1824	K22 040 040
	600 - 23.6	396	1351	K11 040 060				802	2735	K22 040 060
	800 - 31.5	528	1802	K11 040 080				1069	3647	K22 040 080
	920 - 36.2							1299	4194	K22 040 092
	1000 - 39.4	660	2252	K11 040 100				1336	4559	K22 040 100
	1200 - 47.2	792	2702	K11 040 120				1603	5471	K22 040 120
	1400 - 55.1	924	3153	K11 040 140				1870	6383	K22 040 140
	1600 - 63.0	1056	3603	K11 040 160				2138	7294	K22 040 160
	1800 - 70.9	1188	4054	K11 040 180				2405	8206	K22 040 180
	2000 - 78.7	1320	4504	K11 040 200				2672	9118	K22 040 200

Nominal Height 500 mm - 20 in	400 - 15.7	314	1070	K11 050 040				608	2074	K22 050 040
	520 - 20.4	408	1391	K11 050 052				790	2697	K22 050 052
	600 - 23.6	470	1605	K11 050 060				912	3112	K22 050 060
	720 - 28.3	564	1926	K11 050 072				1094	3734	K22 050 072
	800 - 31.5	627	2140	K11 050 080				1216	4149	K22 050 080
	920 - 36.2	721	2461	K11 050 092				1398	4771	K22 050 092
	1000 - 39.4	784	2675	K11 050 100				1520	5186	K22 050 100
	1200 - 47.2	941	3210	K11 050 120				1824	6223	K22 050 120
	1400 - 55.1	1098	3745	K11 050 140				2128	7260	K22 050 140
	1600 - 63.0	1254	4280	K11 050 160				2432	8298	K22 050 160
	1800 - 70.9	1411	4815	K11 050 180				2736	9335	K22 050 180
	2000 - 78.7	1568	5350	K11 050 200				3040	10372	K22 050 200

Nominal Height 600 mm - 24 in	400 - 15.7	338	1152	K11 060 040	520	1776	K21 060 040	668	2278	K22 060 040
	520 - 20.4	439	1498	K11 060 052	677	2308	K21 060 052	868	2961	K22 060 052
	600 - 23.6	506	1728	K11 060 060	781	2663	K21 060 060	1001	3417	K22 060 060
	720 - 28.3	608	2074	K11 060 072	937	3196	K21 060 072	1202	4100	K22 060 072
	800 - 31.5	675	2304	K11 060 080	1041	3551	K21 060 080	1335	4556	K22 060 080
	920 - 36.2	776	2650	K11 060 092	1197	4084	K21 060 092	1535	5239	K22 060 092
	1000 - 39.4	844	2880	K11 060 100	1301	4439	K21 060 100	1669	5695	K22 060 100
	1120 - 44.1	945	3226	K11 060 112				1869	6378	K22 060 112
	1200 - 47.2	1013	3456	K11 060 120	1561	5327	K21 060 120	2003	6834	K22 060 120
	1400 - 55.1	1182	4032	K11 060 140	1821	6215	K21 060 140	2337	7973	K22 060 140
	1600 - 63.0	1350	4608	K11 060 160	2082	7102	K21 060 160	2670	9112	K22 060 160
	1800 - 70.9	1519	5184	K11 060 180	2342	7990	K21 060 180	3004	10251	K22 060 180
	2000 - 78.7	1688	5760	K11 060 200	2602	8878	K21 060 200	3338	11390	K22 060 200

N.B. The tabulated heat outputs are quoted at a mean water to air temperature difference of 50°C.