

Brochure & Technical Guide
March 2012

FLOORTEC Underfloor Heating



heatingthroughinnovation.

heatingthroughinnovation.

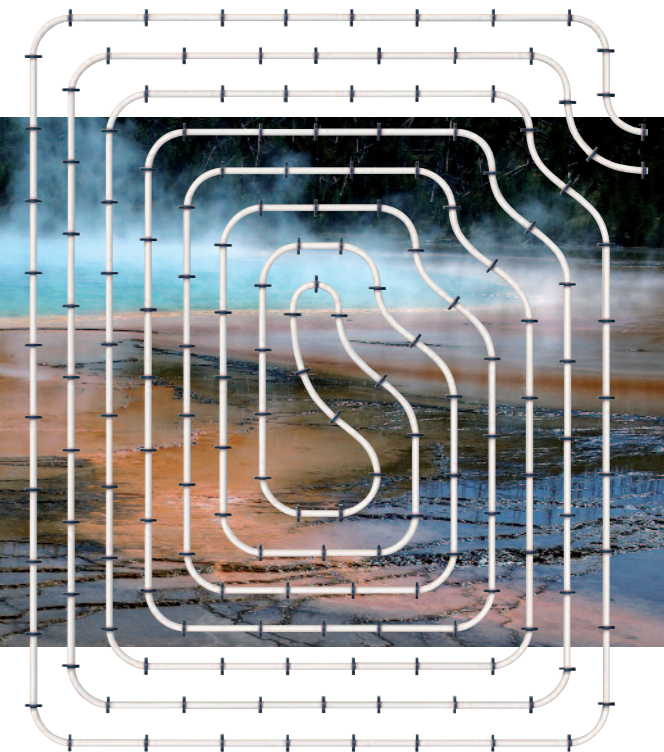

More design. More flexibility.

In recent years underfloor heating has been widely acknowledged as one of the most effective methods of heating. It has become the fastest growing market for both domestic and commercial heating sectors. As one of Europe's leading names in heating technology, **VOGEL&NOOT FLOORTEC** is at the forefront of the underfloor revolution. In addition to our manufacturing and technical expertise, we provide full planning, design and supply services to help you achieve your perfect home.



heating through innovation.

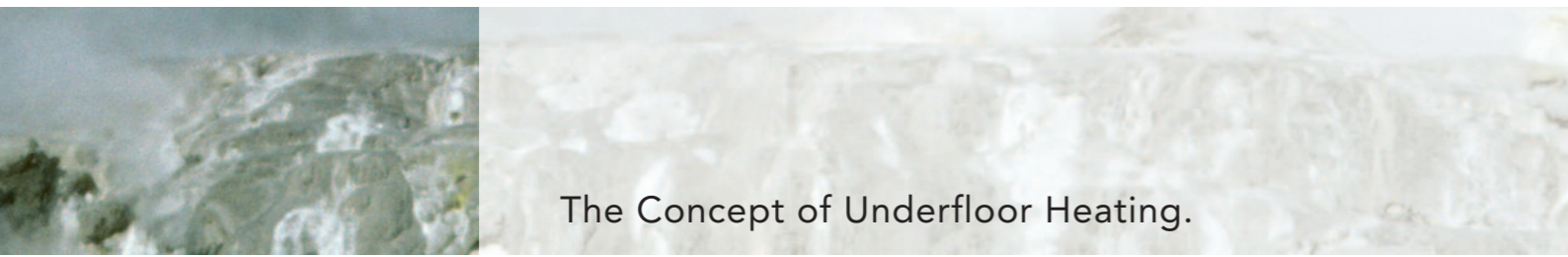

The Concept of Underfloor Heating.



The concept of underfloor heating	06
General heating description	12

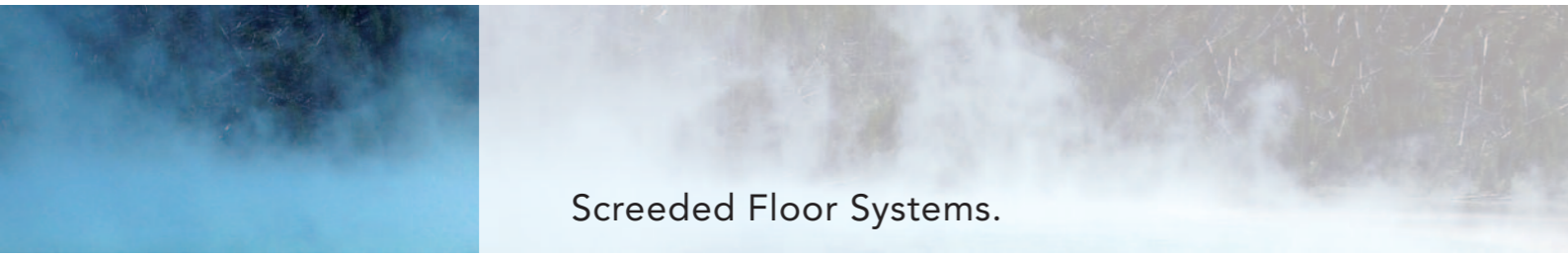

Screeded Floor Systems.

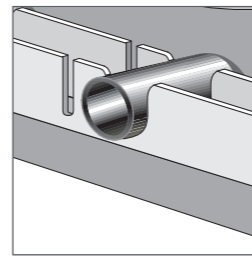

General specification - Screeded floor systems	13
Cliprail	14
Tacker	14
Preformed plate & NEW naked preformed plate	16
Mesh	16

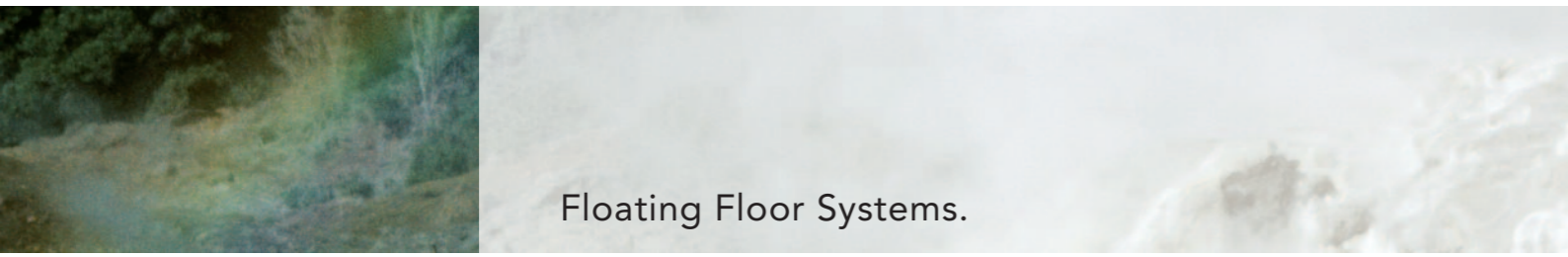

Floating Floor Systems.

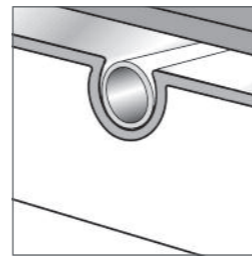

General specification - Floating floor systems	17
------------------------------------------------	----

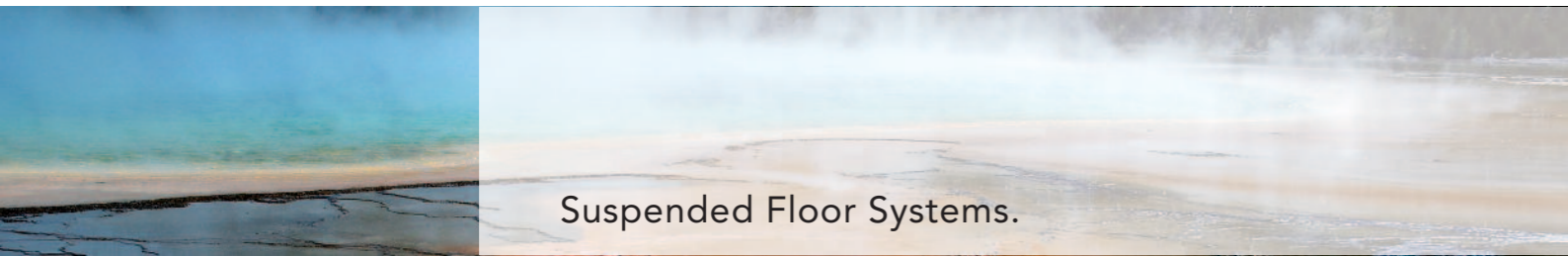

Suspended Floor Systems.

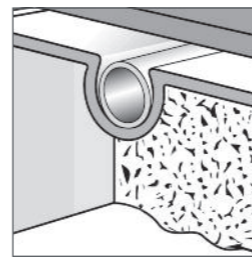

General specification - Suspended floor systems	19
Special floor structures	19

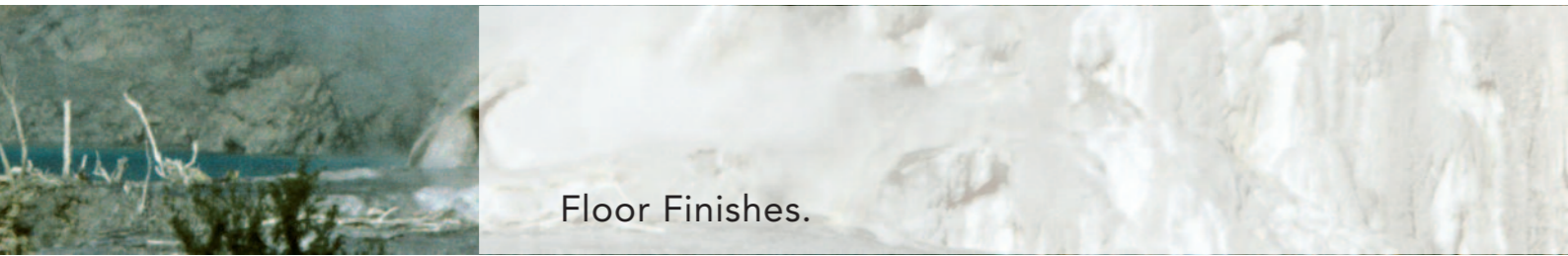

Floor Finishes.

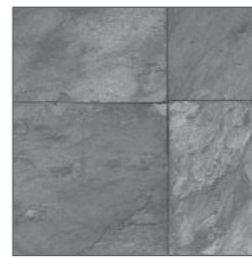

Floor finishes	20
Ceramic	20
Vinyl or plastic	21
Timber	21
Carpets	21

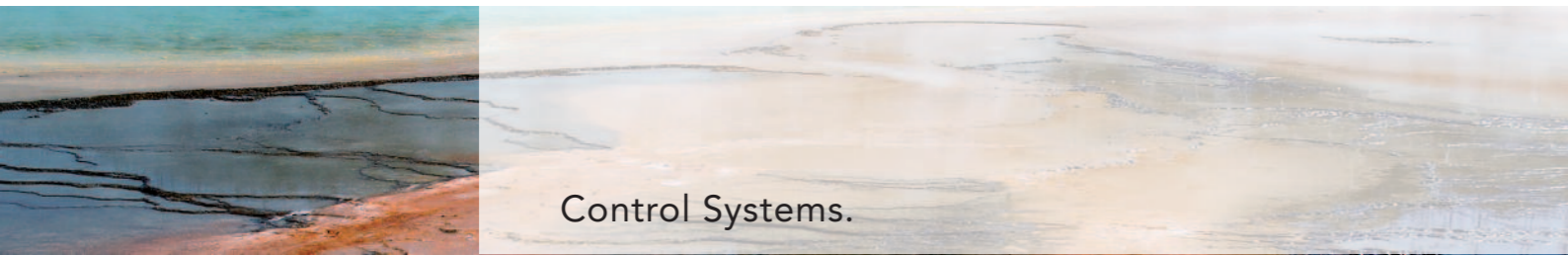

Control Systems.



Control systems	22
Mixed Circuit Flow Diagram	22
Manifold & manifold control centre	23
Hard wired low voltage room thermostats	23
Wireless room thermostats	25
Programmer	25

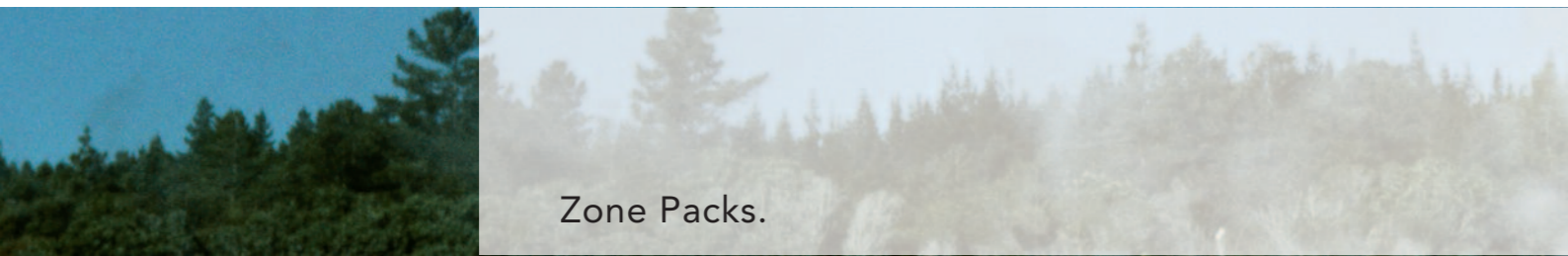

Zone Packs.



Single Zone packs	26
-------------------	----

A better kind of heat.

Underfloor heating works by circulating warm water through a series of continuous pipe loops fitted underneath your floor. The pipework creates a large radiant surface which heats your home from the floor upwards. This radiant form of heating is very different to the convected heat provided by radiators. Radiators work by drawing cold air across your floor, heating it and then convecting it upwards towards the ceiling.

The use of radiant heat rather than convected heat will provide you with a number of significant benefits.

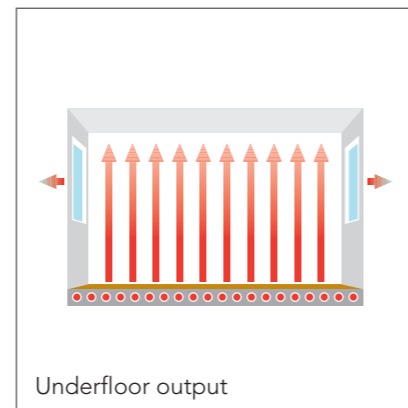
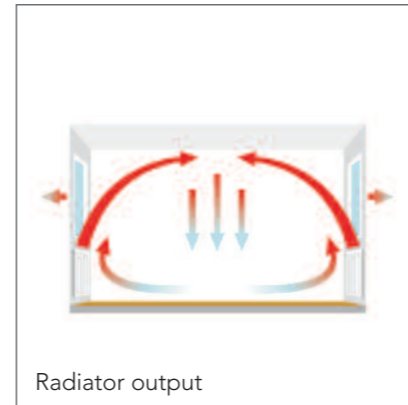

Natural, comfortable warmth.

The main advantage of underfloor heating is its high level of performance. Radiant heat means that the warmth is concentrated where you need it most. Room temperatures higher up are usually around 2°C lower than at floor level. So it's perfect for human comfort - you won't get cold feet and you will keep a cool head!

It's highly controllable heat too. You can make each room a separate zone, varying heat output according to the time of day and location. You'll enjoy uniform heat even in the largest rooms, with no cold spots and no draughts caused by air circulation. It's even good for furniture, with its gentler, more even heat and smaller variations in humidity!



**More benefits.
More flexibility.**

Underfloor heating is also extremely discrete. With nothing showing above floor level, it does not interfere with either your living space or your décor. This leaves you free to make the most of every square foot of your floor and wall space.

It is also a cost effective option. Although installation costs are generally higher than traditional heating methods, underfloor heating's superior efficiency means that your running costs will be significantly lowered so the ongoing savings on your energy bills quickly outweigh your higher initial outlay.

Underfloor heating is even a practical option. It can be used with most types of floors and floor coverings. It is also suitable for use with all sorts of wet central heating systems. It is easy to install and gives you a number of usage options. It can be installed throughout your house, on one level only or in individual rooms. It can be used alone or combined with radiators or other heating systems elsewhere in your home.

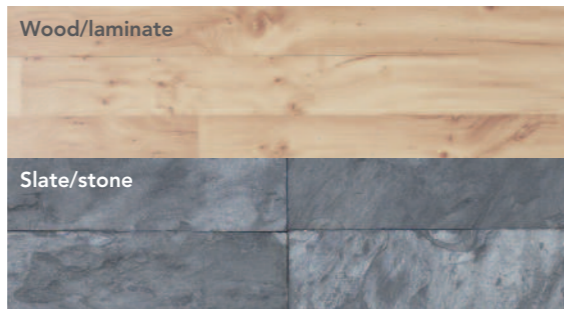

Plated Floor

Suspended floor systems include joisted floors with conventional joists supported on end walls of sleeper walls, as well as solid floors with battens fixed to the floor.

Floating Floor

Floating floors reduce the overall loading on the building, reducing the weight of the floor compared to other floor systems. Floating floors also exhibit very good acoustic properties, reducing sound transmission between floors of a building.

Screeded Floor

Solid floor underfloor heating systems have the underfloor heating pipework embedded in concrete or screed. They include concrete screeded floors and block and beam floors with a screeded finish.

Tacker

Cliprail





More service, More confidence.

VOGEL&NOOT FLOORTEC has introduced a complete system assurance that promotes the advantages of both tried and tested component compatibility and correct system design. We are confident that, when installed correctly, our systems will perform to the highest standards, so eliminating unnecessary problems.



If you decide to buy individual components from different manufacturers, unfortunately there is no overall responsibility for your underfloor heating system, should things go wrong. Buy a bespoke system from **VOGEL&NOOT** and our Complete System Assurance means you will benefit from complete peace of mind.

In addition, you also benefit from our Service Plus technical support, training and reputation.

Once your system is installed, all you have to do is sit back and enjoy the performance, efficiency and design freedom that **VOGEL&NOOT FLOORTEC** underfloor heating provides.



1.0 General Heating Description

All underfloor heating systems must be designed, installed and commissioned in accordance with the CIBSE Underfloor Heating Design and Installation Guide 2004.

VOGEL&NOOT FLOORTEC underfloor heating is suitable for use with all types of wet central heating systems, including gas, oil or solid fuels and conventional, combination or condensing boilers. It is also ideal for mixed systems with, for example, underfloor heating on the ground floor and radiators on the first floor. Due to its lower flow temperatures, underfloor heating works especially well with condensing boilers and renewable energy heat sources, such as heat pumps taking full advantage of the high efficiencies available.

Underfloor heating can be fitted under screed, floating or timber joist floors, and whether your preference is for fitted carpets, vinyls, wood block, ceramic or stone floors, it will provide a warm and comfortable surface underfoot.

The choice of floor covering will of course affect the output of the underfloor circuit and this should be taken into account at the design stage.

To work effectively, underfloor heating requires water temperatures of between 35°C and 55°C. These are easily obtained by blending flow water and return water from the underfloor by means of the thermostatic mixing facility.

Heat Pumps

Heat pumps save energy by extracting heat from an outside source and delivering it within the building. Heat pumps are ideally supplied for use with underfloor heating due to the lower running temperatures required.

When to use underfloor heating

Underfloor heating is suitable for;

- Most housing applications
- Buildings or areas with low heat loss
- Buildings or areas that are continually or frequently used
- Buildings or areas with high ceilings.

Underfloor heating is not suitable for;

- Buildings or areas that are used intermittently or infrequently
- Buildings or areas that have high, or sudden heat losses
- Applications where large amounts of equipment or fittings will be fixed into the floor, eg. racking or shelving
- Buildings where future partitioning or internal wall changes may occur.



2.0 General Specification: Screeded Floor Systems

Description

Solid Floors

Solid floor underfloor heating systems have the underfloor heating pipework embedded in screed or concrete. They include concrete screeded floors and block and beam floors with a screeded finish. **VOGEL&NOOT FLOORTEC** Underfloor Heating systems are available for all of these constructions.

The design and installation of the concrete or screeded floor must conform to the appropriate British Standards and Codes of Practice including BS 8204-1:2003 screeds, bases and in situ floorings. Concrete bases and cement sand levelling screeds to receive floorings. BS 8000-9:2003 Workmanship on building sites. Cementitious levelling screeds and wearing screeds.

VOGEL&NOOT FLOORTEC underfloor heating can offer a solution for all types of screeded and concrete floor constructions with few constraints.

Underfloor Heating in Screeded Floors

Screeded floors are laid onto a sub-base which can be of concrete or beam and block construction. A damp proof membrane should be included within, or on top of, the sub-base. Typical screeded floor sections are detailed on pages 14-15, showing the **VOGEL&NOOT FLOORTEC** underfloor heating pipework in the structure. The composition of the the floor above the sub base shall be identical in both cases.

A layer of insulation, which must meet the requirements of the Building Regulations, is laid directly on to the sub floor. To avoid damage to this insulation, from the screed, a protection layer, which is normally a polyethylene sheet of at least 0.15mm thick, must be included.

VOGEL&NOOT FLOORTEC insulation products have this protection layer bonded to their upper surface. This layer is not however a damp proof membrane or vapour barrier which, if required, must be included elsewhere in the floor construction.

VOGEL&NOOT FLOORTEC PeX underfloor heating pipework is then laid, held in place with one of the five primary anchoring systems, detailed below.

VOGEL&NOOT FLOORTEC underfloor heating can be used with many differing screed constructions, ranging from a traditional sand and cement screed to an anhydrite system. **VOGEL&NOOT FLOORTEC** recommend that the thickness of a typical sand and cement screed shall be between 75mm and 150mm. All screeds must comply with the requirements of BS 8204 and particular attention should be given to bay sizes, which should not exceed 40m² in area, or 8m in any linear dimension. Expansion joints must be used, as required by BS 8204. The screed must not contain any insulating materials.

Underfloor Heating in Concrete Floors

A typical concrete floor section is shown on pg 15-16, giving the common elements of the floor structure and showing the **VOGEL&NOOT FLOORTEC** underfloor heating pipework within the structure.

The sub-base is usually made up of several layers, starting with a compacted or consolidated hard-core.

A blinding layer is added on top of this and a damp proof membrane should be included at this level. A layer of insulation, which must meet the requirements of the Building Regulations, is laid directly on to the sub floor. To avoid damage to this insulation, from the concrete, a protection layer, which is normally a polythene sheet of at least 0.15mm thick, must be included.

VOGEL&NOOT FLOORTEC insulation products have this protection layer bonded to their upper surface. This layer is not, however a damp proof membrane or vapour barrier which, if required must be included elsewhere in the structure.

VOGEL&NOOT FLOORTEC PeX underfloor heating pipework is then laid, held in place with one of the five primary anchoring systems, detailed below.

VOGEL&NOOT FLOORTEC underfloor heating can be used with many differing designs of concrete floor. The make up and thickness of the floor shall depend upon its structural requirements, and detailed advice on floor construction should be sought from a structural engineer, however the floor thickness should not exceed 150mm. The concrete must not contain any insulation materials.

Pipework Anchorage Systems

With solid floor constructions the underfloor heating pipework must be held in place prior to the screed or concrete being laid. **VOGEL&NOOT FLOORTEC** underfloor heating has five primary anchorage systems to meet all possible installation situations. These anchorage systems are cliprail, tacker, 'U' clip only, preformed plate (naked and with 11mm insulation) and mesh.

Transitional Pipe Runs

Areas of dense pipework, such as areas adjacent to the manifold, should be insulated to avoid overheating of the floor.

2.1 Cliprail

Cliprail systems are designed to attach the underfloor heating pipework to floor insulation that is supplied by others. **VOGEL&NOOT FLOORTEC** do not supply any insulation with

cliprail systems, however, we do supply perimeter insulation to cater for the floor's expansion and contraction.

Screeded Floor on Sub Base
(Insulation not supplied)

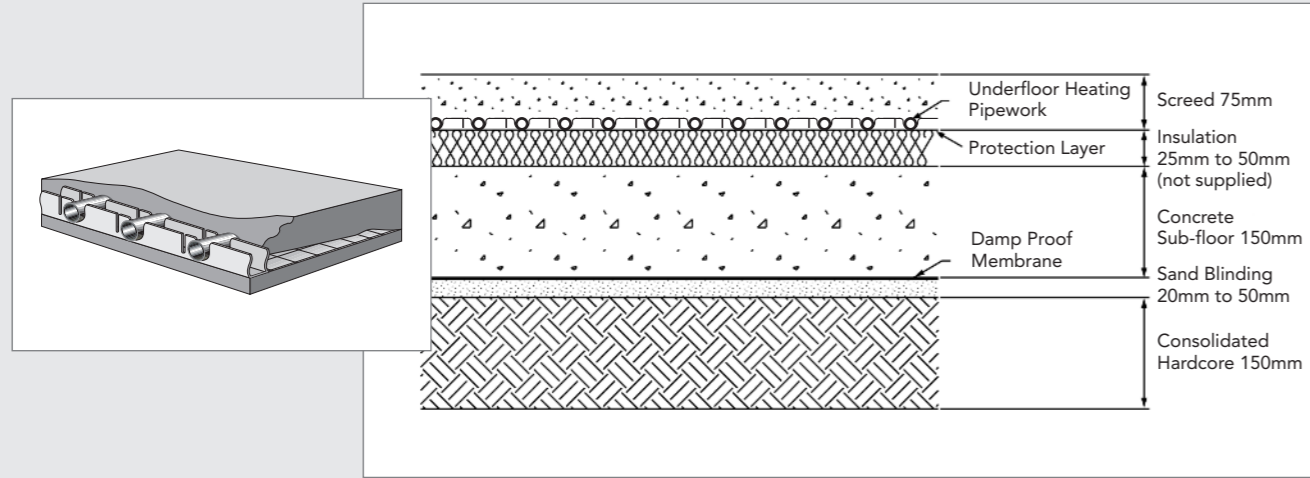

Please note: For additional fixing, anchor clips are available. Suitable for 16 and 17mm pipework.

2.2 Tacker

'U' Clip and Tacker System

VOGEL&NOOT FLOORTEC underfloor heating insulation is a PS20 Expanded Polystyrene (EPS100) with a webbing foil bonded to the top surface. This webbing foil acts as the protection layer and, after laying, all joints must be taped to maintain integrity. A 50mm grid is marked onto the foil to assist in the positioning of the **VOGEL&NOOT FLOORTEC** PeX underfloor heating pipework.

The pipe is positioned in place and then a barbed 'U' clip is fixed over the pipe by means of a **VOGEL&NOOT FLOORTEC** tacker. The barbs snag on the webbing material holding the pipe until the screed or concrete is laid. The tacker stapler may be either purchased or hired from **VOGEL&NOOT FLOORTEC**. Perimeter insulation is also supplied to cater for the floor's expansion and contraction.

This is a fast and effective method of anchoring the **VOGEL&NOOT FLOORTEC** PeX underfloor heating pipework and is very flexible allowing both spiral and serpentine laying patterns.

Note: **VOGEL&NOOT FLOORTEC** PS20 insulation is part of the underfloor heating pipe fixing method and is not designed to comply with the requirements of the Building Regulations.

Additional insulation, by others, may therefore be required.

PS20 (EPS100)

mm	Quantity	Thermal Conductivity
25	10m ²	0.040 W/mK
50	10m ²	0.040 W/mK

Tacker



Tacker in Use

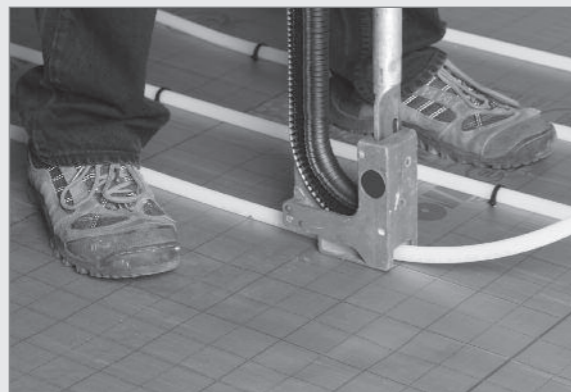

'U' Clips

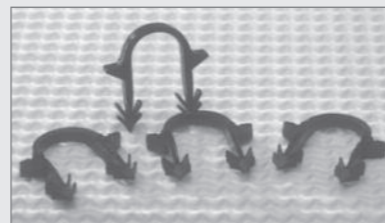

2.3 Screeded Floor on Sub Base (Tacker System Shown)

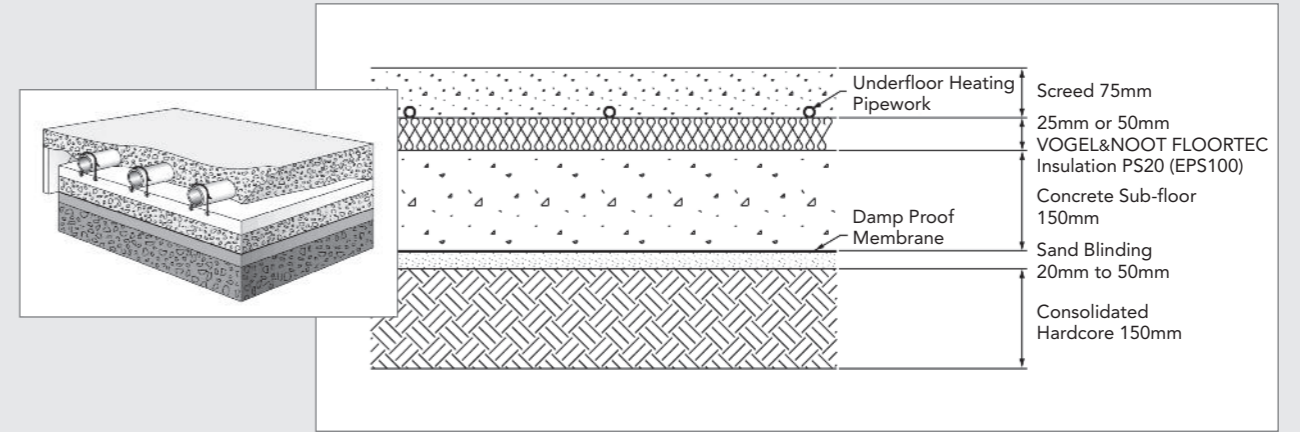

2.4 Screeded Floor on Block and Beam Base (Tacker System Shown)

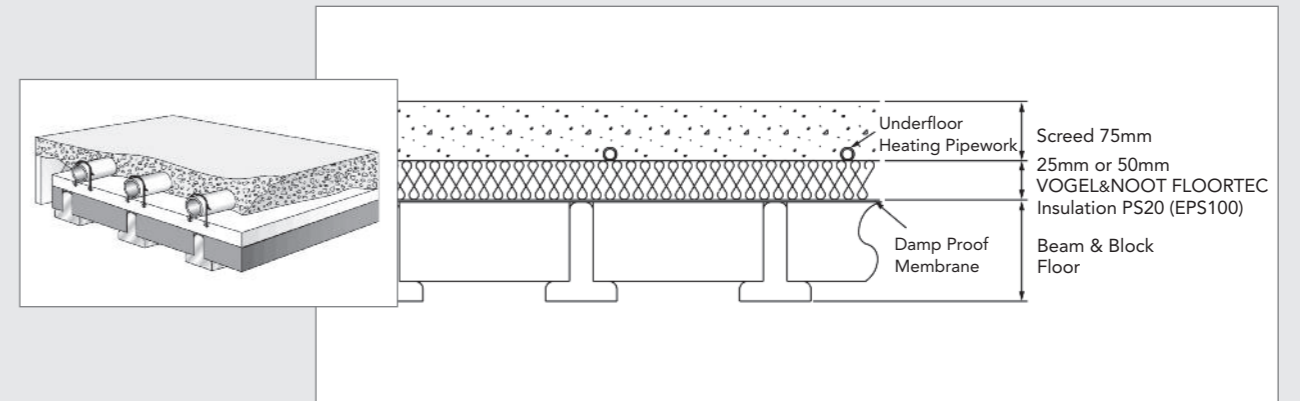

2.5 Concrete Floor Structure (Tacker System Shown with Reinforcing Mesh)

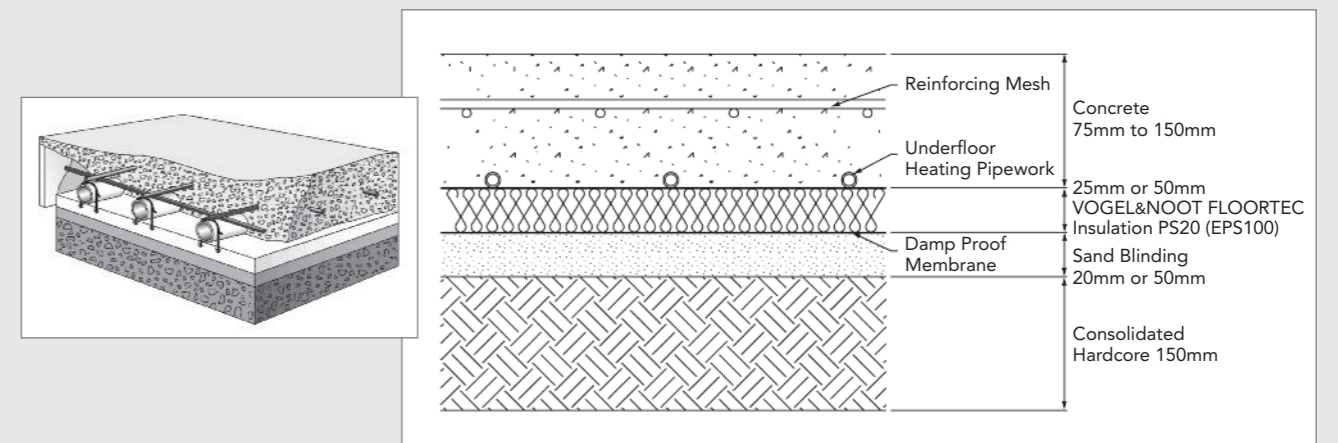

2.6 Preformed Plate (Suitable for 14 - 17mm pipework)

The preformed plate underfloor heating system is ideal for a single person installation and utilises 14 - 17mm pipework. A castellated fixing system comprises of an 11mm expanded polystyrene base with raised burls designed to firmly grip the pipework. Preformed plate is laid over the concrete sub floor

and is covered with floor screed, as with the other systems. The preformed plate system is also supplied with a foam perimeter tube which helps prevent the screed from travelling under the plates.

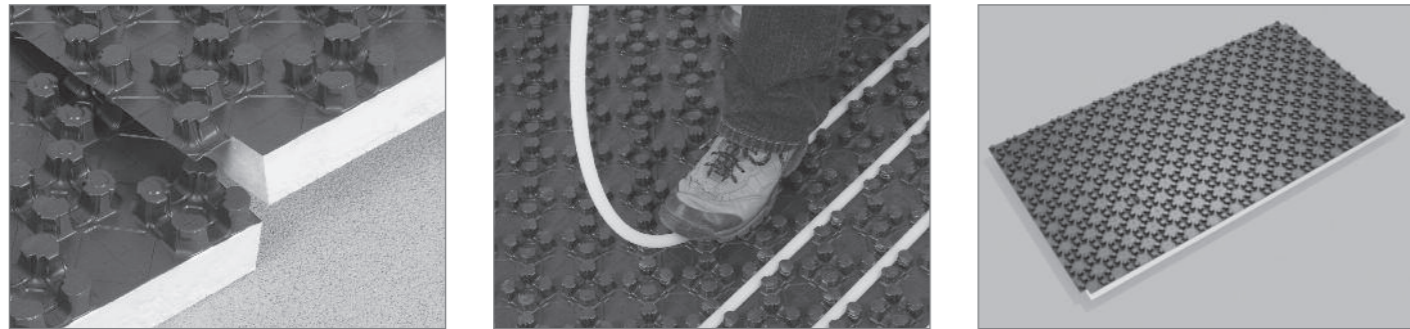

NEW Naked Preformed Plate

The naked preformed plate system is designed as a more cost effective, streamlined version of the preformed plate system when space is at a premium. The castellated fixing system comprises of raised burls designed to firmly grip the **VOGEL&NOOT FLOORTEC** heating pipe. The naked preformed plate is laid over a concrete sub floor or insulation and is covered with floor screed, as with the other systems.

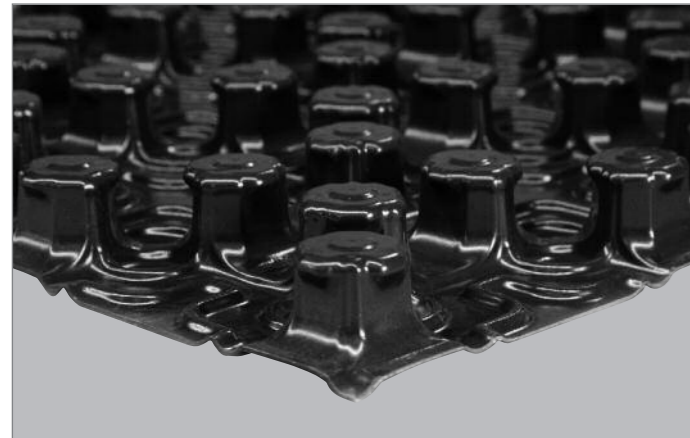

2.7 Mesh

This type of system is equally suitable for screeded and concrete floors.

Mesh systems consist of **VOGEL&NOOT FLOORTEC** underfloor heating pipework being attached to a steel reinforcing mesh (generally A142), which itself is laid over the floor insulation. Cable ties are the normal method of connection between the underfloor heating pipe and the mesh.

The insulation, which must meet the requirements of the Building Regulations, is laid directly on to the sub floor. To avoid

damage to this insulation, from the screed, concrete or mesh, a protection layer which is normally a polyethylene sheet of at least 0.15mm thick, must be laid directly above the insulation.

Should a mesh system be used with a liquid screed, the mesh must be securely fixed in place prior to the installation of the screed.

2.7 Mesh (cont...)

Mesh System
(Concrete floor structure shown)

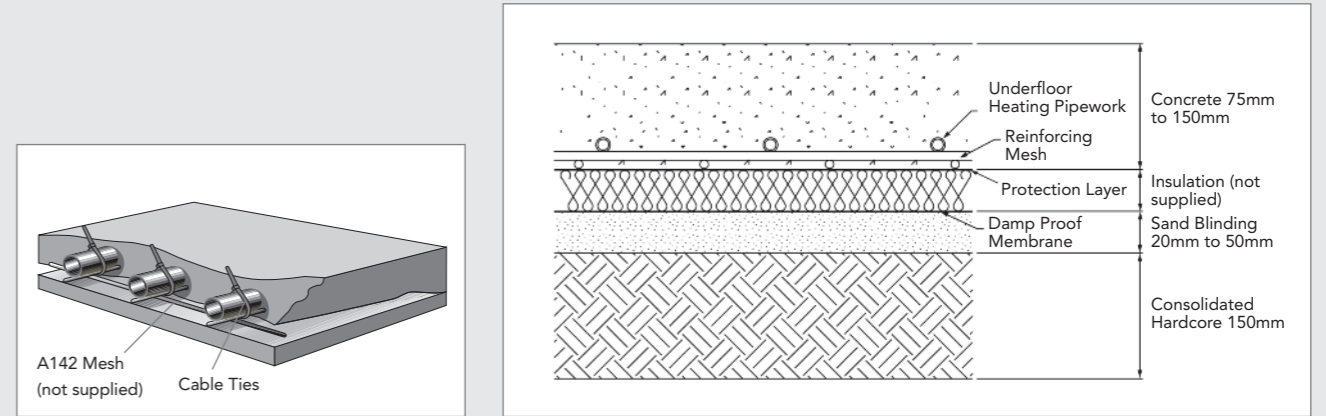

3.0 General Specification: Floating Floor Systems

Description

A floating floor underfloor heating system has been developed by **VOGEL&NOOT FLOORTEC** to meet the increasing demand for this type of flooring structure. Floating floor systems have a low thermal mass and consequently have a swift response time to changes in temperature. Floating floors also reduce the overall loading on the building, minimising the weight of the floor compared to other floor systems. Suitable for 16mm multilayer pipework only.

Installation Outline

The CIBSE Underfloor Heating Design and Installation Guide 2004, section 7.2.4 states: Thermal expansion of plastic pipes above ground is considerable, and 10mm per linear metre must be expected with water at 60°C. However expansion of pipes embedded in solid concrete is prevented and results in a microscopic bore reduction. **VOGEL&NOOT FLOORTEC** therefore recommend ample provision for pipe expansion is provided in all systems where the heating pipe is not buried in screed or concrete. This may be accommodated by regular changes of pipe direction.

- Extruded Polystyrene panels are pre-grooved with grooves on 200mm centres.
 - 30mm thick made from XPS Extruded Polystyrene
 - 40mm thick made from XPS Extruded Polystyrene
 - 50mm thick made from XPS Extruded Polystyrene
 - Panel dimensions - 2400mm x 1200mm

- A U-shaped groove is provided at one end of each panel to allow for turning of the pipework at the end of a run.
- The grooves are dimensioned to accept aluminium diffusion plates, which spread the heat from the underfloor heating pipework to the floor.
- Panels are laid with the U-shape at each end of the room, with the sheets butt jointed and cut to size.
- Once the panels are laid aluminium diffusion plates are laid onto the sheets with the grooves in the plates fitting into the grooves in the polystyrene panel.
- To allow for transitional pipework, the floating floor panels may be grooved using a proprietary heat gun.
- After installing the pipework, these areas are covered with flat aluminium plates to assist with heat distribution.
- Underfloor heating pipework is walked into the grooves in the plate and, after pressure testing, the floor decking is floated onto the floor.
- **VOGEL&NOOT FLOORTEC** recommend that areas of dense transitional pipe should be insulated.
- The decking will conventionally be a tongue and grooved flooring material with the panels glued together along the tongue and groove.
- Adhesive should be applied to both sides for the joint to ensure a sound fixing.
- The floor decking is left 10mm short of the walls of the room to allow for expansion of the decking and is held in place at the edges, usually by the skirting board.

3.1 Floor Sections

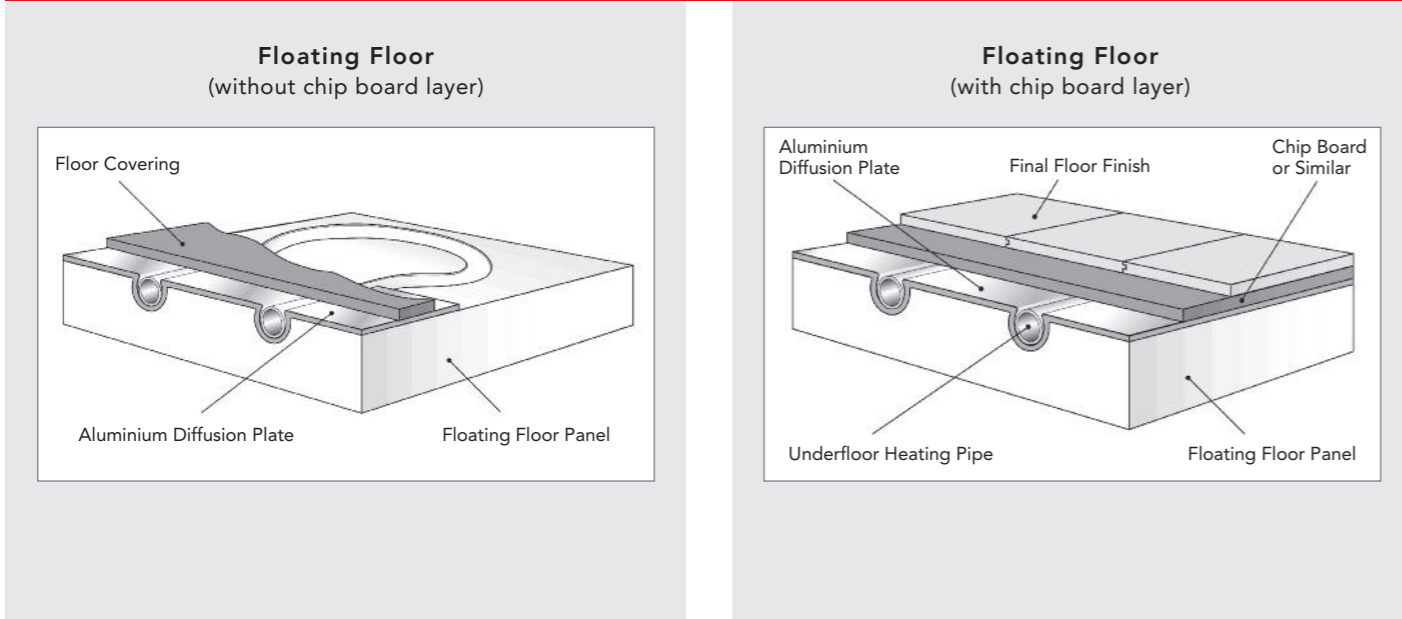

Performance

Compression Resistance

All materials are compressed under load. Insulation materials used in floors should be capable of accommodating the applied loads with the minimum of compression. The floating floor panels are manufactured by Knauf Insulation, from their Polyfoam range of products, to a unique VOGEL&NOOT FLOORTEC specification. They are highly resistant to compression and withstand both occasional and long term static loads. A factor of safety for design loads of 3 (5 for long term static loads) is applied to the compressive strength of the product as outlined in the product data table.

Floating Floor Product Data

Thickness (mm)	30	40	50
Length (mm)	2400	2400	2400
Width (mm)	1200	1200	1200
Nominal Density (Kg/m ²)	30	30	30
Thermal Conductivity (W/mK)	0.029	0.029	0.029
Minimum Compressive Strength (kPa)	200	200	200
Design Loads* Long Term Static Load (kPa)	40	40	40
Design Loads* Occasional Loading (kPa)	66	66	66
Water Vapour Resistance (MNs/gm)	480	480	480
Moisture Absorption (by vol.)	0.3%	0.3%	0.3%
Continuous Service Temp Limits °C	-50 to +75	-50 to +75	-50 to +75

*Design loads by calculated methods (BBA).

Materials

The Knauf Polyfoam products are HCFC and CFC free, are 100% ozone friendly, and are manufactured in accordance with European Directive EC 3093/94 and EC Regulation 2037/2000.

Outputs

VOGEL&NOOT FLOORTEC underfloor floating floor systems have an effective output up to 70 W/m².

4.0 General Specification: Suspended Floor Systems

The CIBSE Underfloor Heating Design and Installation Guide 2004, section 7.2.4 states: Thermal expansion of plastic pipes above ground is considerable, and 10mm per linear metre must be expected with water at 60°C. However expansion of pipes embedded in solid concrete is prevented and results in a microscopic bore reduction. VOGEL&NOOT FLOORTEC therefore recommend ample provision for pipe expansion is provided in all systems where the heating pipe is not buried in screed or concrete. This may be accommodated by regular changes of pipe direction.

Description

Suspended floor systems include joisted floors with conventional joists supported on end walls of sleeper walls, as well as solid floors with battens fixed to the floor. The underfloor heating system consists of aluminium diffusion plates fitted between the joists or battens. We can supply plates for 17mm pipework.

If the floor structure contains engineered joists, then a floating floor should be considered.

Installation Outline

For VOGEL&NOOT FLOORTEC underfloor heating to function effectively the heat from the PeX underfloor heating pipework must be distributed as evenly as possible across the floor. In solid floor constructions the screed accomplishes this. With timber suspended floors an aluminium plate is used to conduct the heat from the pipework and distribute it across the floor. Aluminium is used for its excellent thermal conduction as well as its low weight.

With all plated systems, it is extremely important that the floor covering MUST be in direct contact with the diffuser plates to ensure efficient heat conduction and optimum heat output from the floor.

Plates are manufactured from aluminium sheet and are available in three sizes (see table). Grooves pressed into the plate are sized

to accept 17mm PeX pipework, holding it firmly in place without damage to the pipe or external oxygen diffusion barrier.

The floor void must be insulated with either loose fill insulation, such as vermiculite, or mineral wool insulation, such as Rockwool (both not supplied by VOGEL&NOOT FLOORTEC). It is essential that air movement in this void is reduced to a minimum otherwise excess heatloss will occur.

Following installation of the insulation material the aluminium diffusion plates are fitted in place and are secured either by nails or double-sided adhesive tape. An area of 300mm to 350mm at the end of each joist run is left clear of plates to allow for the pipe turns.

Gaps of 75mm to 150mm are also left between plates to allow for movement of the plate and pipework without risk of damage. This is necessary as PeX plastic pipe has a high coefficient of thermal expansion and some movement of the pipework and plates can be expected.

Once the plates have been fitted, the underfloor heating pipework is installed into the grooves in the plates. The underfloor heating pipework must be wrapped with insulation whenever it passes through a joist notch. All joist notching should be in accordance with Building Regulations. As with all other systems, VOGEL&NOOT FLOORTEC recommend areas of dense transitional pipe should be insulated. Finally, after pressure testing, the floor finish is laid.

Aluminium Diffusion Plates for 17mm pipework

All 1000mm Long / 0.6mm Thick		
Plate Width (mm)	Joist Centres (mm)	Pipe Centres (mm)
388	400	200
588*	600	200

*Special order only.

4.1 Special Floor Structures

The plated underfloor heating system can be easily adapted to accommodate a number of special floor details including sprung floors, acoustic pads and cross battens.

Sprung Floor

With battens loose laid on to blocks supported on a solid base, the underfloor heating is fitted in the normal manner but using double sided tape to hold the plates in position. This avoids dislodging the battens when fixing the plates.

Acoustic Pads

To reduce sound transmission from the floor an acoustic pad may be included in the floor make up. This pad should be fitted to the top of the joist or batten with the diffusion plate fixed to the pad with double sided tape. Fixings must not penetrate the pad as this will lead to acoustic bridging. Please note that these pads cannot be supplied by VOGEL&NOOT FLOORTEC.

Cross Battens

If joist centres are not suitable for placing of the diffusion plate or cannot be notched for structural reasons, the floor can be cross battened with the battens set at 400mm centres. The underfloor heating can then be laid onto the cross battens. Insulation must, however, still be installed directly under the diffusion plates. Alternatively, a floating floor system may be installed over the floor.

Performance

Outputs

Outputs from plated underfloor heating systems are limited to 70 W/m². Floor loadings are unaffected by the underfloor heating and will be dependent upon the floor construction.

4.1 Special Floor Structures (cont...)

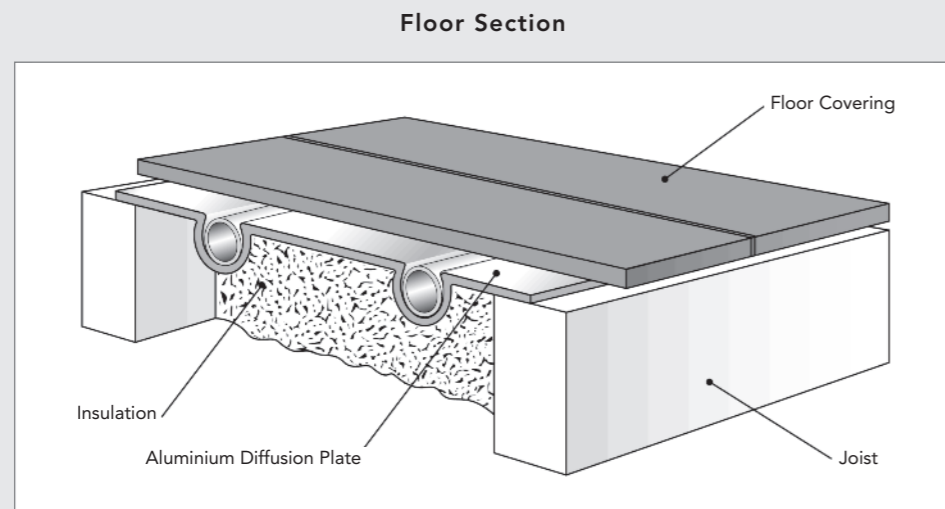

5.0 Floor Finishes

When considering the output for a mean water temperature and pipe centre combination, the floor finish must also be taken into account. Floor finishes with greater thermal resistance reduce the output from the underfloor heating.

There are four basic floor finish types which should be considered: ceramic, which includes natural stone and manufactured stone materials such as flag stones; plastic or vinyl floor coverings; timber and timber products; and carpet.

Typical floor finishes and their corresponding resistance to heat transfer are detailed in the table below. Ceramic finishes have the least thermal resistance with carpets having the greatest. When selecting carpet and underlay combinations the combined thermal resistance should not exceed a value of approximately 0.15m² K/W (or a 1.5 tog rating).

Suspended and Floating Floor Systems

With floating and suspended floor systems it is possible to vary the mean water temperature but the pipe spacing will be fixed by the system type. All suspended and floating floor systems have 200mm pipe centres. Due to the system characteristics the maximum output from both suspended and floating floor systems is 70W/m².

Ceramic Floor Finishes

Ceramic flooring products, such as tiles have a low thermal resistance, typically 0.02m²K/W, and will function very well with **VOGEL&NOOT FLOORTEC** underfloor heating systems. This low thermal resistance is the reason for this type of floor finish feeling cold to the touch (without the benefit of underfloor heating).

Temperature constraints do not apply to ceramic type floor finishes and these can be run at the maximum design floor surface temperatures, 29°C in general areas and 35°C in bathroom, perimeter and wet areas.

Differential thermal expansion between the ceramic floor finish and the screed must be taken into account during the floor design. This differential expansion limits the areas that can be laid without the inclusion of a thermal expansion joint. Underfloor heating standard BS EN 1264 limits this area to 40m² with a maximum length of 8m, after which the area should be split using a flexible expansion material. Specific advice must be sought from the tile supplier.

Another important consideration is the propagation of cracks within the screed and the potential for the cracks to extend into the floor finish. All screeds will crack and it is the limiting of the propagation of these cracks that must be considered. Two possible solutions are available:

- The inclusion of a reinforcing mesh approximately 25mm from the upper surface of the screed.
- The use of a fibre-bonded screed to help limit crack propagation. In this type of screed small fibres are added to the screed mix, which provide bridging across any developing crack.

Performance

Outputs

Outputs are based on a flow water temperature of 50°C, a return water temperature of 40°C, pipe centres of 200mm and a room temperature of 20°C.

5.0 Floor Finishes (cont...)

Typical Output

Floor Finish	Typical Thermal Resistance m ² K/W	Typical Tog Rating	Output Watts/m ²
Screed / Ceramic Tile	0.020	0.20	112
Vinyl	0.075	0.75	87
Carpet - Standard	0.10	1.00	73
Timber / Carpet - Thick	0.15	1.50	62

Note: Thermal outputs above are calculated in accordance with BS EN 1264. Should a floor heat output exceed the maximum surface temperature of 29°C for occupied zones, it is represented in red.

Plastic or Single Floor Coverings

In general vinyl and plastic type floor finishes have a low thermal resistance, 0.07m²K/W and will function well with **VOGEL&NOOT FLOORTEC** underfloor heating. There are a small number of specialist plastic floor finishes that can be classified, as plastic but these will have higher thermal resistance. Some sports hall floor coverings are made from a 'foamed' plastic and the thermal resistance of such coverings should be checked before their use with **VOGEL&NOOT FLOORTEC** underfloor heating. A resistance of up to 0.15m²K/W to 0.20m²K/W will function satisfactorily with **VOGEL&NOOT FLOORTEC** underfloor heating but above this value the design of the system must be checked.

Vinyl and plastic floor coverings are flexible in nature and therefore differential expansion will not cause any problems to the stability of the floor structure. The floor covering manufacturer must be contacted for specific advice as most vinyl and plastic floors must not be subjected to temperatures in excess of 27°C.

A vinyl covering will seal the surface of the screed and therefore the curing and drying of the screed must be carried out before the floor covering is laid. If this is not done, damage to the screed or the floor covering could result either with moisture being trapped between the screed and the floor covering. This may result in the floor covering failing. The screed must be allowed to cure for a minimum of 21 days and then heated by the **VOGEL&NOOT FLOORTEC** underfloor heating until the moisture has been removed. Starting with the flow temperature set to approximately 30°C and then elevated by 2°C to 3°C per day until the operating temperature is reached and then held at this temperature for 5 days. After this period the heating is turned off and the floor covering can be laid. The requirement for preconditioning of screeds is detailed in EN 1264:Pt4 and must be followed.

A limit thermostat can be fitted to the floor to ensure its surface does not exceed any maximum temperature specified by the floor covering manufacturer.

Timber and Timber Products

Timber products present their own problems with regards to use with **VOGEL&NOOT FLOORTEC** underfloor heating which relate to the moisture content of the timber and screed. Thermal resistances of timber products usually fall within the acceptable range for use with **VOGEL&NOOT FLOORTEC** underfloor heating (0.15m²K/W, 1.5 tog).

Timber is a natural material and in its raw state will have high moisture contents. If this were laid onto a **VOGEL&NOOT FLOORTEC** underfloor heating system without due consideration the timber would shrink when heated, causing excessive gaps between 'planks' as well as the possibility of warping. To avoid these problems the timber product moisture content must be no greater than 10% with kiln dried timber being most widely used. Where older 'well seasoned' timber is to be used this should be stacked in the heated room for a minimum of two weeks with the heating running at its operating temperature, which will ensure that the moisture within the timber is removed.

As the floor is heated the residual moisture in the timber will be removed and the timber will shrink. This shrinkage is minimal as long as the timber used has a low moisture content and the maximum surface temperature is limited to 27°C.

When laid onto a screed it is essential that the moisture within the screed be removed before the timber is laid otherwise the moisture will penetrate the timber resulting in warping. The same process is used to dry the screed allowing it to fully cure for a minimum of 21 days. The **VOGEL&NOOT FLOORTEC** underfloor heating should be set at a flow temperature of 30°C and elevate the flow temperature by 3°C per day until the operating temperature is reached. Operating temperatures must be held for a minimum of 5 days before the **VOGEL&NOOT FLOORTEC** underfloor heating is turned off and the flooring is laid.

The requirement for preconditioning of screeds is detailed in EN 1264:Pt4 and must be followed.

Carpets

Although care in selection of carpets and their associated underlay must be taken to avoid excessive thermal resistance they present few problems to **VOGEL&NOOT FLOORTEC** underfloor heating. The thermal resistance of the carpet and underlay combination should not exceed 0.15m²K/W (1.5 tog).

Carpet is flexible and therefore does not present any differential expansion problems, it is also permeable to moisture transfer and therefore will allow moisture to be expelled from the screed during the drying process.

6.0 Control Systems

Control Systems

Underfloor heating requires water flow temperatures of approximately 35°C to 55°C dependent upon the design, heat loading and type of the system used. The system should be balanced to achieve an approximate temperature differential of between 8°C and 10°C measured between the flow and return pipes.

Constant Temperature Systems

The VOGEL&NOOT FLOORTEC underfloor heating system mixes return water from the underfloor heating with flow water from the primary pipework. The mixed temperature is controlled at a constant temperature and the proportions of flow and return water are varied accordingly. Mixing is undertaken in a three port mixing valve, incorporating a thermo-electrical valve controller.

Programming

All VOGEL&NOOT FLOORTEC underfloor heating systems are supplied with the comprehensive timing options. This ranges from the traditional MEP1C programmer to the sophisticated MPRT programmable room thermostat.

Smart Start Technology

This varies the start-up times of the underfloor heating system on a room by room basis to ensure that each room in the building achieves the desired temperature by the required time.

The Smart Start system is continually learning the temperature rise requirement of each room, delaying the start up of the system, therefore saving energy during milder weather. Smart Start technology is available with both the VOGEL&NOOT FLOORTEC MPRT and MPRT RF programmable room thermostats.

Night Set Back Temperatures

Depending on the specific requirements of the User, it may be preferable to operate the system with a night or unoccupied set back temperature. This allows each room to maintain an individually programmed minimum background level of heat during an 'OFF' period. This facility is available with both the VOGEL&NOOT FLOORTEC MPRT and MPRT RF range of programmable room thermostats.

Set back has two distinct advantages when used with underfloor heating. It maintains the building fabric at a temperature, avoiding large swings in temperature and freezing, and it reduces the heat up period when the system is started after an off period.

Set back temperatures will normally be approximately 15°C dependent upon the building usage and occupants requirements.

Individual Room Control

Individual rooms fed from the same manifold are controlled by means of room thermostats and VOGEL&NOOT FLOORTEC thermoelectric actuators. VOGEL&NOOT FLOORTEC thermoelectric actuators can be supplied in 230 volt and 24 volt options and are designed for simple snap fitting to the regulating valves on the return header of the manifold. They operate by means of wax filled bellows with a heating element. When there is a call for heat the heating element is energised, heating the wax, which expands, causing the valve to open.

- **Wired** - The room thermostats are normally wired through a VOGEL&NOOT FLOORTEC 24V wiring centre. This has the advantage of providing a boiler and pump demand as well as connections for time channel input.
- **Wireless** - If it is impractical to install hard wired thermostats, VOGEL&NOOT FLOORTEC offer a range of wireless thermostats that use a radio frequency (RF) signal to communicate between the room thermostat and the wiring centre. Basic analogue (wireless) or digital programmable (MPRT RF) units are available.

6.1 Mixed Circuit Flow Diagram

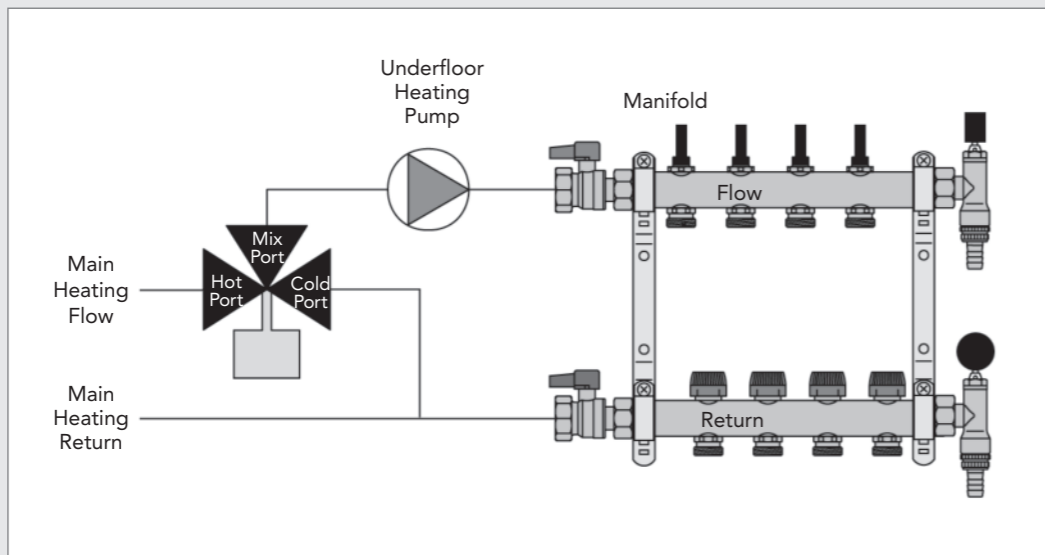

6.2 Manifold and Manifold Control Centre

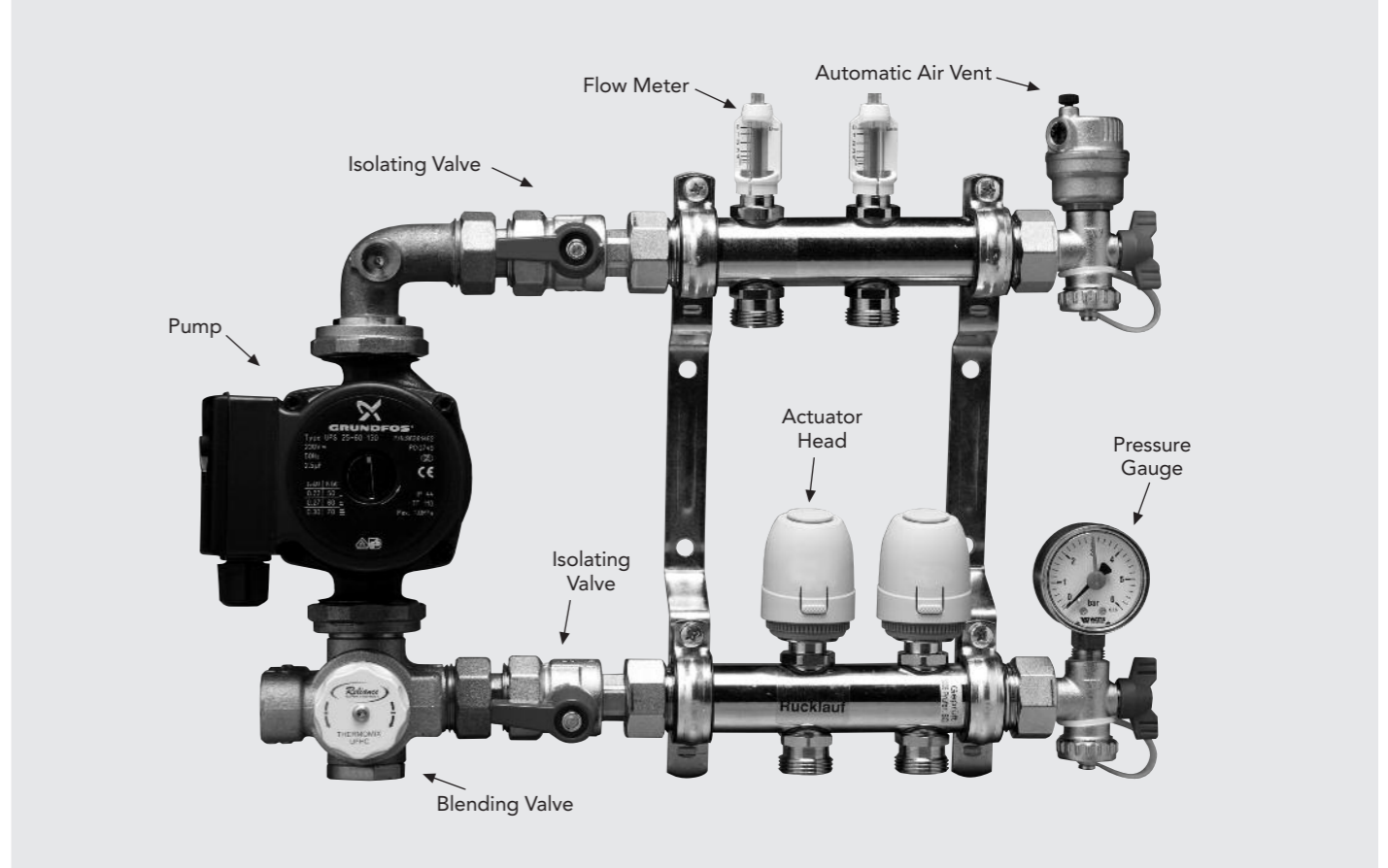

6.3 Hard Wired Low Voltage Room Thermostats

Wiring Centre

- 24V Supply
- 24V to room stats and actuators
- Can control up to 10 heating thermostats
- Can control up to 12 actuators.



MRTE - Electronic Room Thermostat

- Upmarket electronic thermostat
- Attractive slimline design
- Clear, accurate LCD display
- Displays actual temperature
- No neutral, two wire connection
- One thermostat can control several loops
- 24V connection to hard wired wiring centre.



6.3 Hard Wired Low Voltage Room Thermostats (cont...)

MPRT and MPRT RF - Programmable Room Thermostat

- Available with 24V hard wired or wireless options
- Easy to use slimline multifunctional thermostat
- Seven-day programming
- Three temperature settings - comfort, economy (set back) and frost
- Four programmes (three preset, one adjustable) with manual override
- Clear, accurate LCD display
- Vacation delay setting from 1 hour - 50 days
- Installer optional adjustments (differential, calibration, heat, frost setting, high and low limit adjustment settings, password protection)
- No neutral, two wire connection
- MPRT is suitable to be classified as both a "Delayed Start" thermostat as defined in SAP 2005
- One thermostat can control several loops
- Smart Start Technology (saves fuel by delaying heating 'start up' on warm days).



Hard wired diagram showing one MPRT stat operating 3 actuators (3 circuits in room) and switching to zone valve and UFH pump

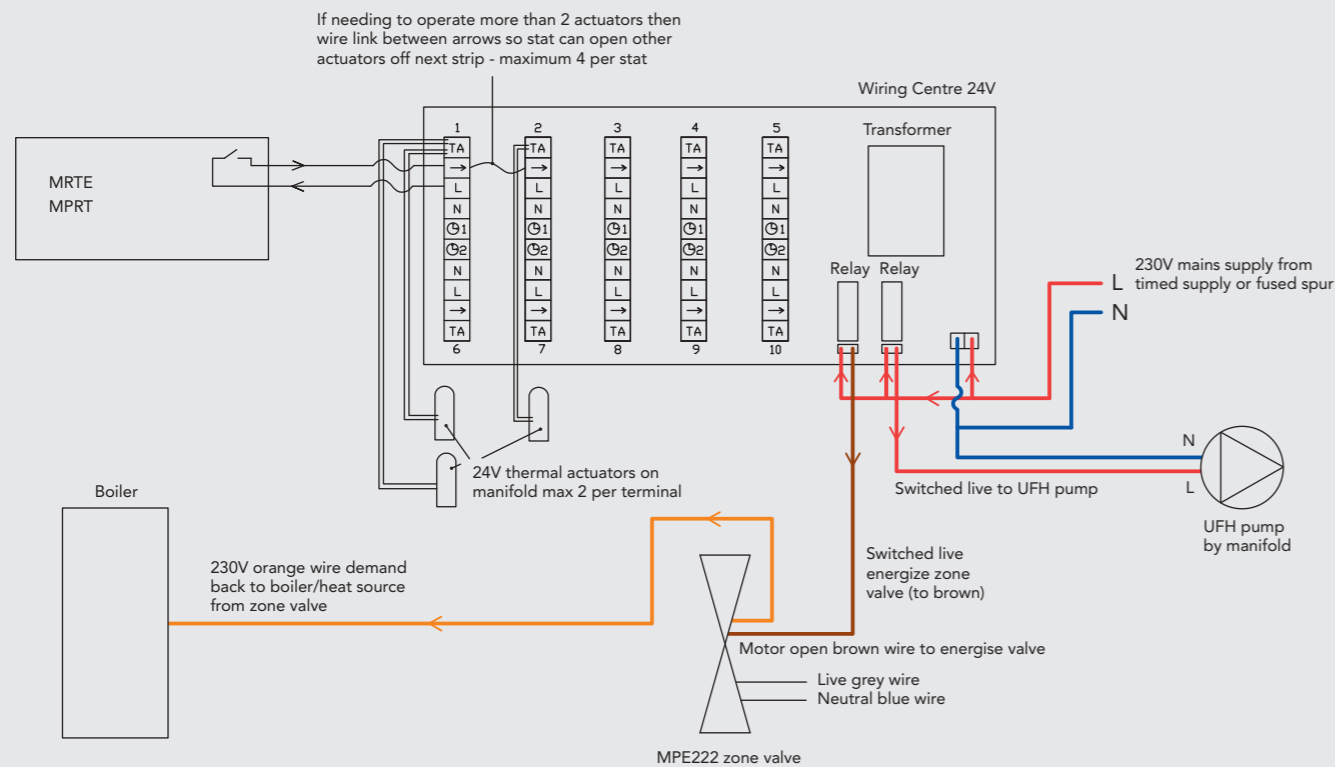

6.4 Wireless Room Thermostats

Thermostat

- No external wiring connections
- 30 metre spherical transmission range
- Ambient temperature 0 - 50°C
- One thermostat can control several loops
- Temperature scale 10-30°C +/- 2K
- Battery service life - minimum 5 years.

Base Unit

- 230V supply
- Can control up to 20 actuators and 6 room thermostats
- Units can be joined for larger applications.

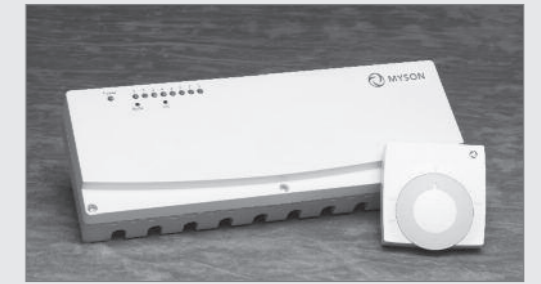

Wireless Diagram

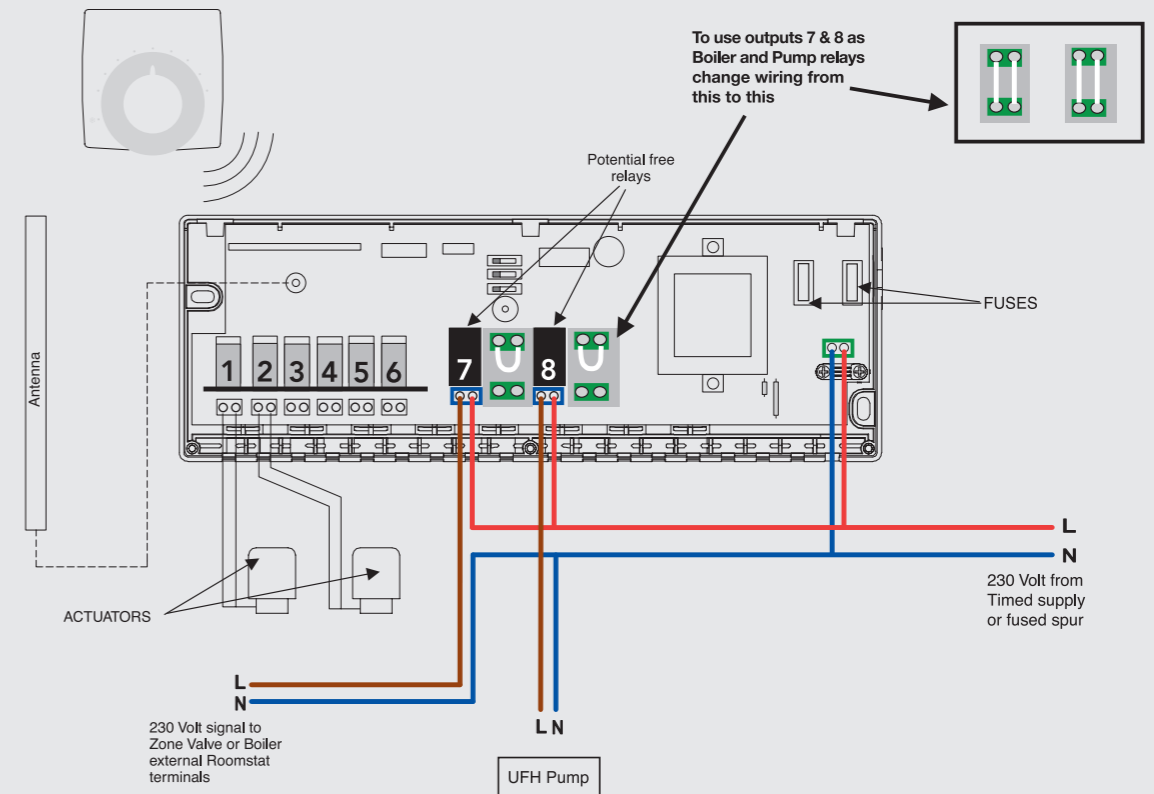

6.5 Programmer

MEP1C - Programmer

- Can be set for 24hr, 5/2 day or 7 day operation
- Easy to read, backlit screen
- Pre-set clock
- Automatic summer/winter time change
- Memory saver - programmer and clock will not require resetting in the event of power loss
- Advanced and up to 3 hour extend features
- Time switches are ideal for combination boilers and control of additional zones etc (voltage free contacts).



7.0 Single Zone Packs

Plan the installation carefully, and consider the following:

- The underfloor heating must be connected to a traditional two pipe heating system
- Carefully consider the manifold position so it is both near the area(s) to be heated, and also easily connected to the heating pipework
- We recommend that the underfloor heating be connected as a separate timed heating zone
- This may require an additional timer and zone valve, which are not supplied. Should it be connected into an existing heating zone, consideration must be given to the response time of the heating system
- If you are unsure of any of the above points, contact your heating engineer.

The single zone packs consist of a **VOGEL&NOOT FLOORTEC** compact underfloor heating control unit that takes heat from a normal heating system and distributes it into a screeded floor, via manifolds and 17/2 PeX pipe. The installation instructions for the **VOGEL&NOOT FLOORTEC** compact underfloor heating control unit are supplied in its box, and are not covered in detail here.



Flow Temperature °C	Floor Covering	Outputs Watts/sq.m
40	ceramic	71
	carpet / wood	46
	thick carpet	39
45	ceramic	94
	carpet / wood	61
	thick carpet	52
50	ceramic	117
	carpet / wood	76
	thick carpet	65
55	ceramic	140
	carpet / wood	91
	thick carpet	78

Important Notes

Care must be taken when using underfloor heating with floor coverings, which may be affected by heat, such as wood or vinyl products. Consult the flooring manufacturer for guidance.

The underfloor heating installer must ensure the heat requirement of the area to be heated is within the potential outputs detailed above. Supplementary heating may be required if the heat requirement is in excess of the above outputs, if the system is to be operated intermittently, or a swift response time is required. **VOGEL&NOOT FLOORTEC** is not responsible for providing any form of temperature guarantee.

These figures assume 200mm pipe spacings, a 75mm deep screed, 8°C difference between the 17/2 PeX-a underfloor heating flow and return and an air temperature of 20°C. Calculated in accordance with BSEN 1254-:1997.

7.0 Single Zone Packs (cont...)

