

UNITEC 

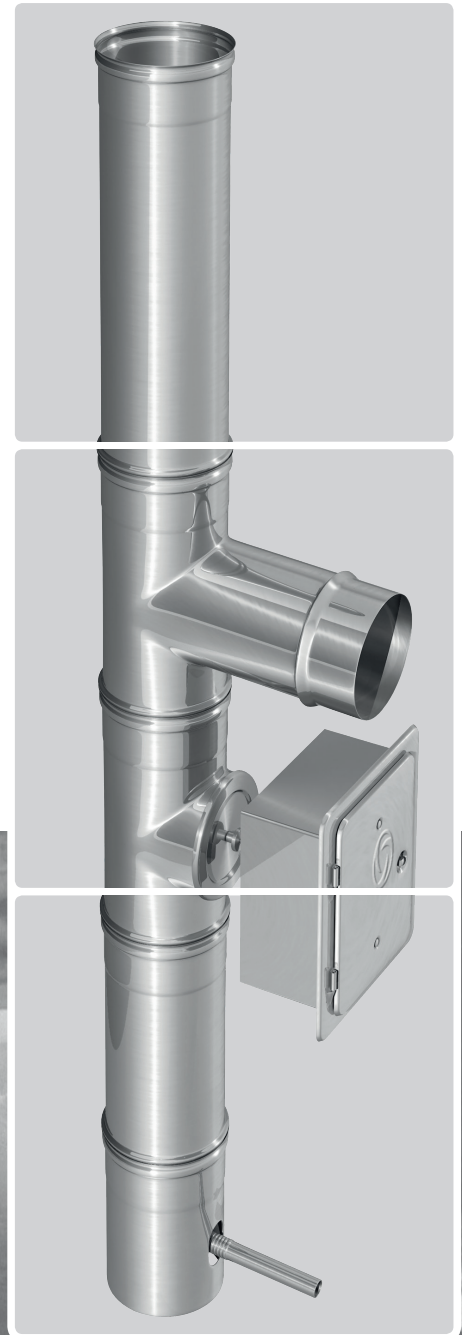

heatingthrough**innovation.**

UNITEC



DE Allgemeines

Die Montage der Abgasanlage muss den nationalen und regionalen baurechtlichen Vorschriften und Normen entsprechen. Stimmen Sie sich gegebenenfalls mit den entsprechenden Behörden ab (z.B. BezirksschornsteinfegermeisterIn).

Es ist darauf zu achten, dass in der Verbrennungsluft keine halogenhaltigen Bestandteile (z.B. Fluor, Chlor, usw.) enthalten sind. Luft in geschlossenen Räumen (z.B. Schwimmbäder, Wäschereien, Entlackungsbetriebe) und Abgase mit diesen Bestandteilen können zu Korrosion der Abgasanlage führen.

EN General

The installation of the exhaust system must comply with the national and regional building regulations and standards. Where applicable, please contact and comply with the corresponding public authorities (e.g. district master chimney sweep).

Care must be taken to ensure that no halogen-bearing elements (e.g. Fluorine, Chlorine, etc.) are contained in the combustion air. Air in enclosed spaces (e.g. swimming pools, laundromats, paint removal plants) and exhaust gases with these elements can lead to corrosion of the exhaust system.

FR Généralités

Le montage de l'installation de gaz d'échappement doit être conforme aux règlements et normes nationaux et régionaux relevant du droit de construction. Se conformer aux textes des autorités compétentes (par exemple, ramoneurs en chef au niveau des districts).

Veiller à ce que l'air de combustion ne contienne pas de composants à teneur en halogène (par exemple fluorine, chlore, etc.). L'air dans des locaux fermés (par exemple piscines couvertes, blanchisseries, ateliers de décapage) et les gaz d'échappement contenant de tels composants peuvent entraîner la corrosion de l'installation de gaz d'échappement.

NL Algemeen

De montage van het uitlaatsysteem moet overeenstemmen met de nationale en regionale voorschriften en normen ivm bouwrecht. Gelieve eventueel af te stemmen met de competente overheden (bv districtsschoorsteenvegermeester).

Het is noodzakelijk om ervoor te zorgen dat er geen halogeenhoudende stoffen (bv fluor of chloor) in de verbrandingslucht zijn. Lucht in gesloten ruimtes (bv zwembaden, wasserijen, aflakkerijen) en uitlaatgassen met deze stoffen kunnen leiden tot de corrosie van het uitlaatsysteem.

DA Generelt

Monteringen af aftræksanlægget skal udføres i overensstemmelse med de nationale og regionale byggetekniske forskrifter og standarder. Afstem i givet fald monteringen med de pågældende myndigheder (f.eks. den ansvarlige skorstensfejer).

Sørg for, at forbrændingsluften ikke indeholder halogenholdige komponenter (f.eks. fluor, klor osv.). Luft i lukkede rum (f.eks. svømmehaller, vaskerier, aflakningsvirksomheder) og røggasser med disse komponenter kan medføre korrosion i aftræksanlægget.

IT Generalità

L'installazione del circuito di scarico deve essere eseguita in conformità alle disposizioni e norme nazionali e regionali in materia di legislazione edilizia. Si consulti eventualmente con le autorità competenti (p.e. responsabile distrettuale degli spazzacamini).

È necessario fare attenzione che nell'aria di combustione non siano presenti componenti alogenati (p.e. fluoro, cloro, etc.). La copresenza in luoghi chiusi (p.e. piscine, impianti di lavaggio, imprese di sverniciatura) di aria e gas di scarico contenenti questi componenti può condurre alla corrosione del circuito di scarico stesso.

UNITEC CE



Abgassysteme:
UNITEC No. DoP 001/FC4-2013-07-01
UNIFLEX No. DoP 001/FCF-2013-07-01

*** Zutreffende Produktkennzeichnung bitte entsprechend ankreuzen ***

Klassifikation EN 1856-2										
Ausf. ¹⁾	ND						Innenrohr EN-1856-2	Verbindungsstück EN-1856-2		
Starres Innenrohr UNITEC										
4	80-600	T600	N1	D	V3	L50050	G ¹⁾	<input type="checkbox"/>	G150 M ¹⁾	<input type="checkbox"/>
5	80-600	T600	N1	W	V2	L50050	G	<input type="checkbox"/>	G400 M	<input type="checkbox"/>
6	80-600	T600	N1	W	V2	L50050	G ²⁾	<input type="checkbox"/>	G200 M ²⁾	<input type="checkbox"/>
7	80-600	T400	N1	W	V2	L50050	O	<input type="checkbox"/>	O400 M	<input type="checkbox"/>
8	80-600	T400	N1	W	V2	L50050	O ²⁾	<input type="checkbox"/>	O50 M ²⁾	<input type="checkbox"/>
9	80-600	T200	H1	W	V2	L50050	O	<input type="checkbox"/>	O50 M	<input type="checkbox"/>
10	80-600	T200	H1	W	V2	L50050	O ²⁾	<input type="checkbox"/>	O10 M ²⁾	<input type="checkbox"/>
11	80-600	T120	H1	W	V2	L50050	O	<input type="checkbox"/>	O50 M	<input type="checkbox"/>
11	80-600	T120	H1	W	V2	L50050	O ²⁾	<input type="checkbox"/>	O00 M ²⁾	<input type="checkbox"/>
Flexibles Innenrohr UNIFLEX mit UNITEC Bauteilen										
1	80-250	T600	N1	W	V2	L50010	G	<input type="checkbox"/>		
2	80-250	T200	P1	W	V2	L50010	O	<input type="checkbox"/>		

¹⁾ Nummerierung nach Leistungserklärung; ²⁾ mit 3 cm dicker Dämmschale; ²⁾ mit 2 cm dicker Dämmschale

Anlagenkennzeichnung EN 15287-1 und -2: _____

Nenndurchmesser: _____ mm Wärmedurchlasswiderstand: _____ m²K/W
ohne Schicht 0,0 m²K/W

Montagefirma: _____ Einbaudatum: _____

Warnhinweis: Dieses Schild darf nicht abgedeckt oder entfernt werden



Abgassystem:
UNITEC No. DoP 001/FC4-2013-07-01
Systemabgasanlage (Ohne Schacht)

*** Zutreffende Produktkennzeichnung bitte entsprechend ankreuzen ***

Klassifikation EN 1856-1										
Ausf.	ND									
Systemabgasanlage UNITEC										
1	80-300	T600	N1	D	V2	L50050	G400	<input type="checkbox"/>		
	350-450						G600	<input type="checkbox"/>		
	500-600						G800	<input type="checkbox"/>		
2	80-300	T200	H1	W	V2	L50050	G50	<input type="checkbox"/>		
	350-450						G75	<input type="checkbox"/>		
	500-600						G100	<input type="checkbox"/>		
3	80-300	T120	H1	W	V2	L50050	G50	<input type="checkbox"/>		
	350-450						G75	<input type="checkbox"/>		
	500-600						G100	<input type="checkbox"/>		

Anlagenkennzeichnung EN 15287-1: _____

Nenndurchmesser: _____ mm Wärmedurchlasswiderstand: 0,0 m²K/W

Montagefirma: _____ Einbaudatum: _____

Warnhinweis: Dieses Schild darf nicht abgedeckt oder entfernt werden



(DE)

Der beiliegende Anlagenaufkleber mit CE Kennzeichnung muss ausgefüllt und an jeder Abgasanlage sichtbar und dauerhaft angebracht werden!

(EN)

The attached installation sticker with CE identification must be filled out in the national language and visibly and permanently mounted on every exhaust system!

(FR)

Remplir dans la langue du pays la vignette au code CE ci-jointe d'une encre indélébile et la coller durablement sur l'installation de gaz d'échappement !

(NL)

De bijgevoegde sticker met CE-kenmerking dient in de landstaal te worden ingevuld en moet zichtbaar en blijvend aang ebracht worden op elk uitlaatsysteem!

(DA)

Det vedlagte anlægsmærkat med CE-mærkning skal udfyldes og fastgøres på et synligt og fast sted på aftræksanlægget!

(IT)

L'etichetta adesiva qui allegata, munita di marcatura CE, deve essere compilata nella rispettiva lingua nazionale e applicata su ciascun circuito di scarico in modo visibile e duraturo!

min. 

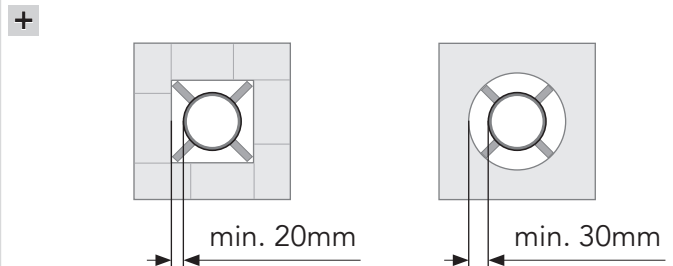
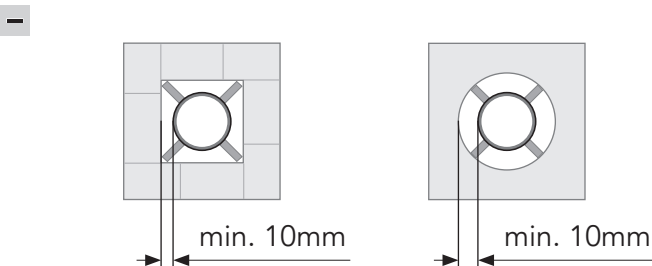

 UNITEC - +

UNITEC -

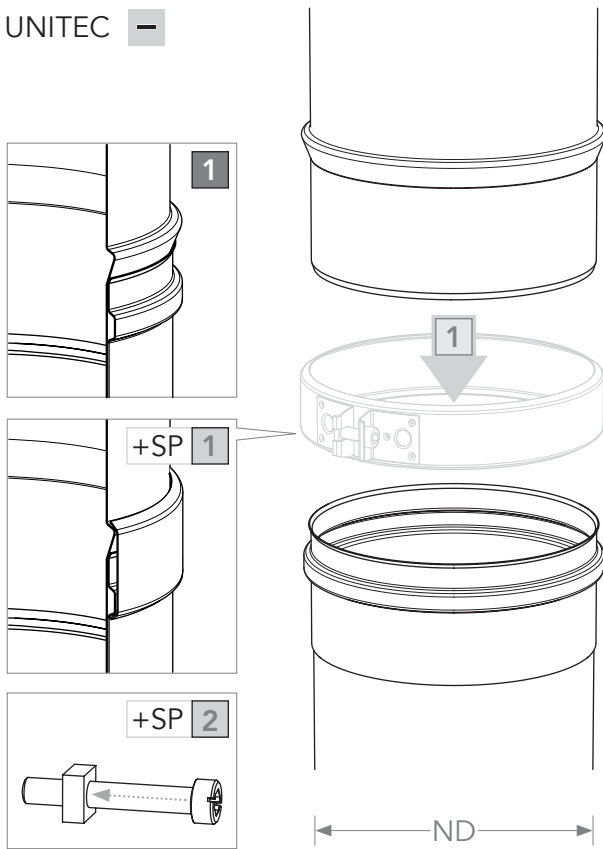

UNITEC +

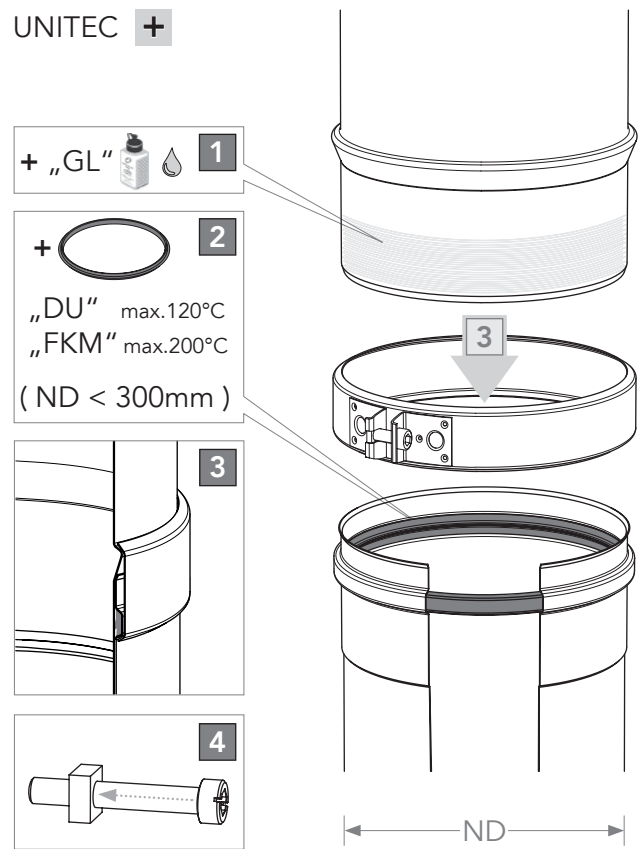

 „JL“

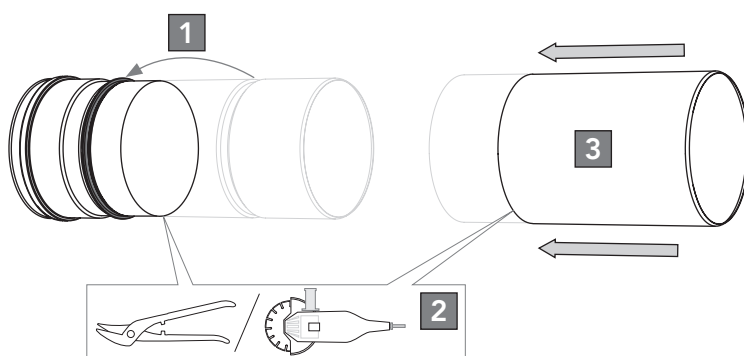
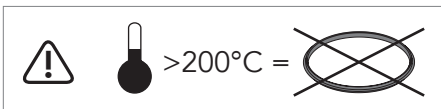
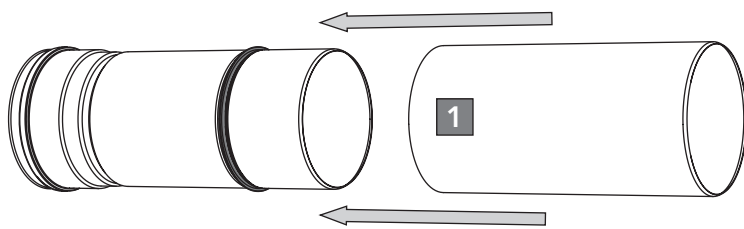

„JL“

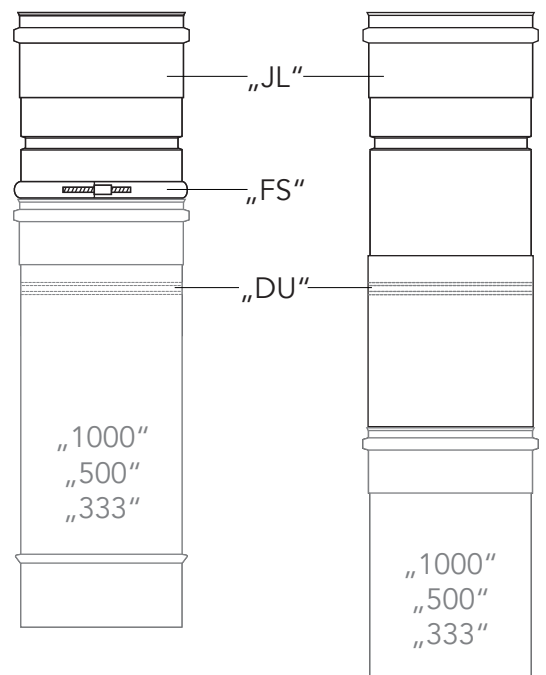

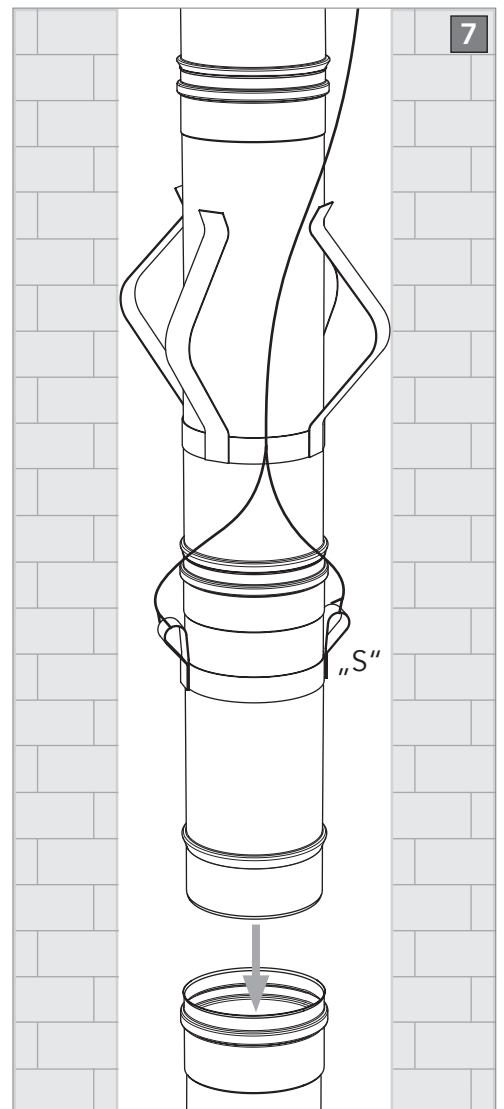
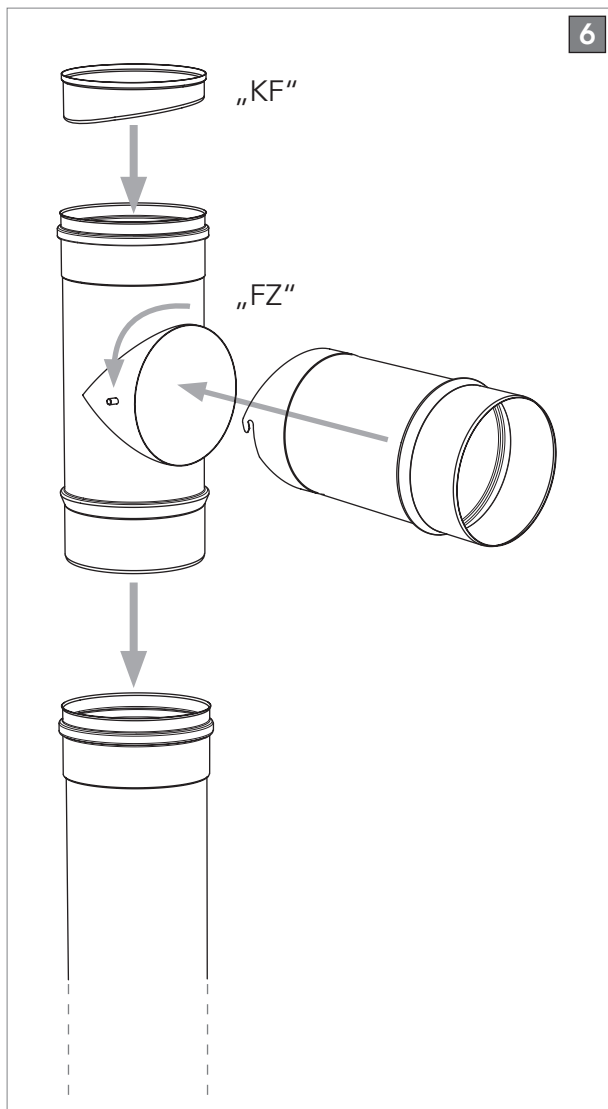
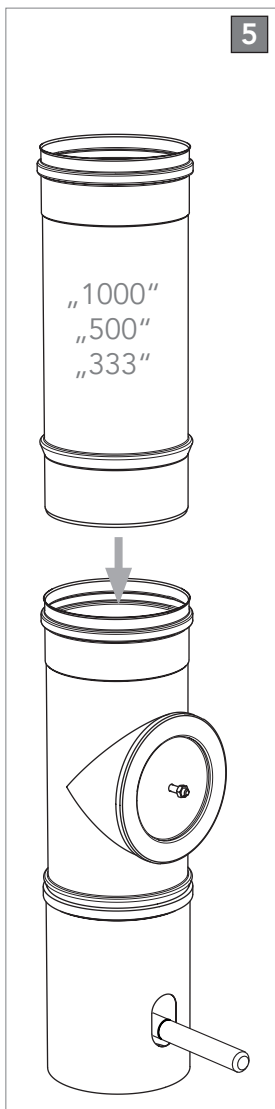
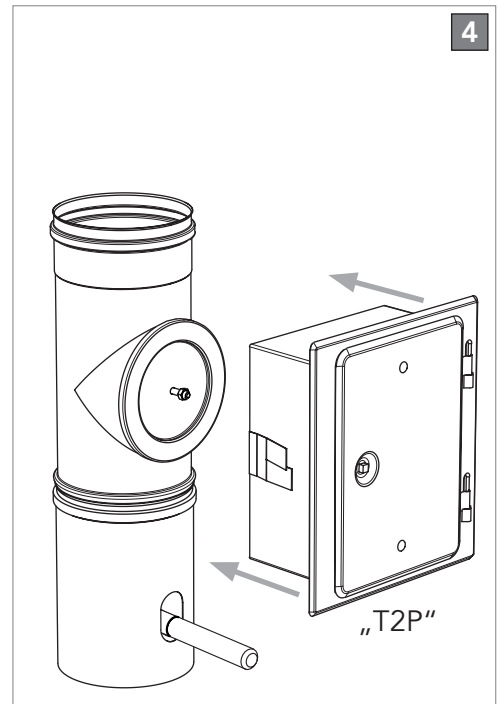
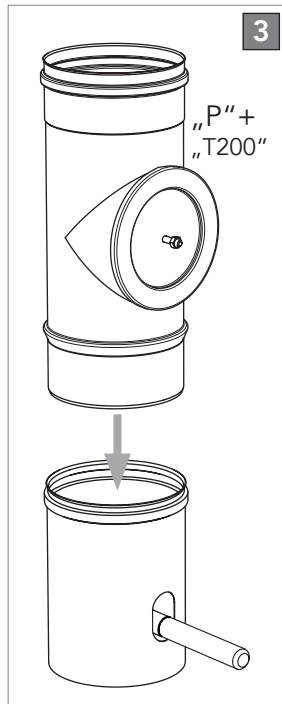
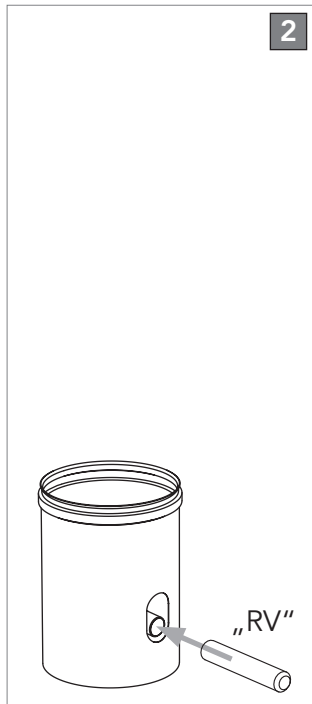
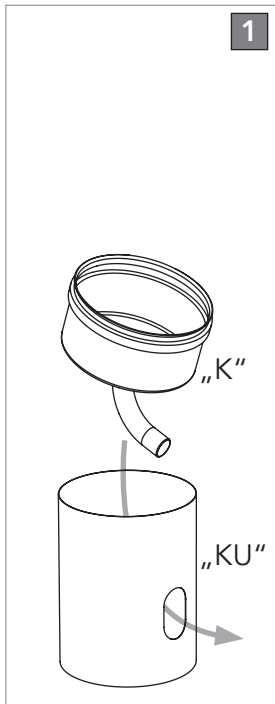

 UNITEC

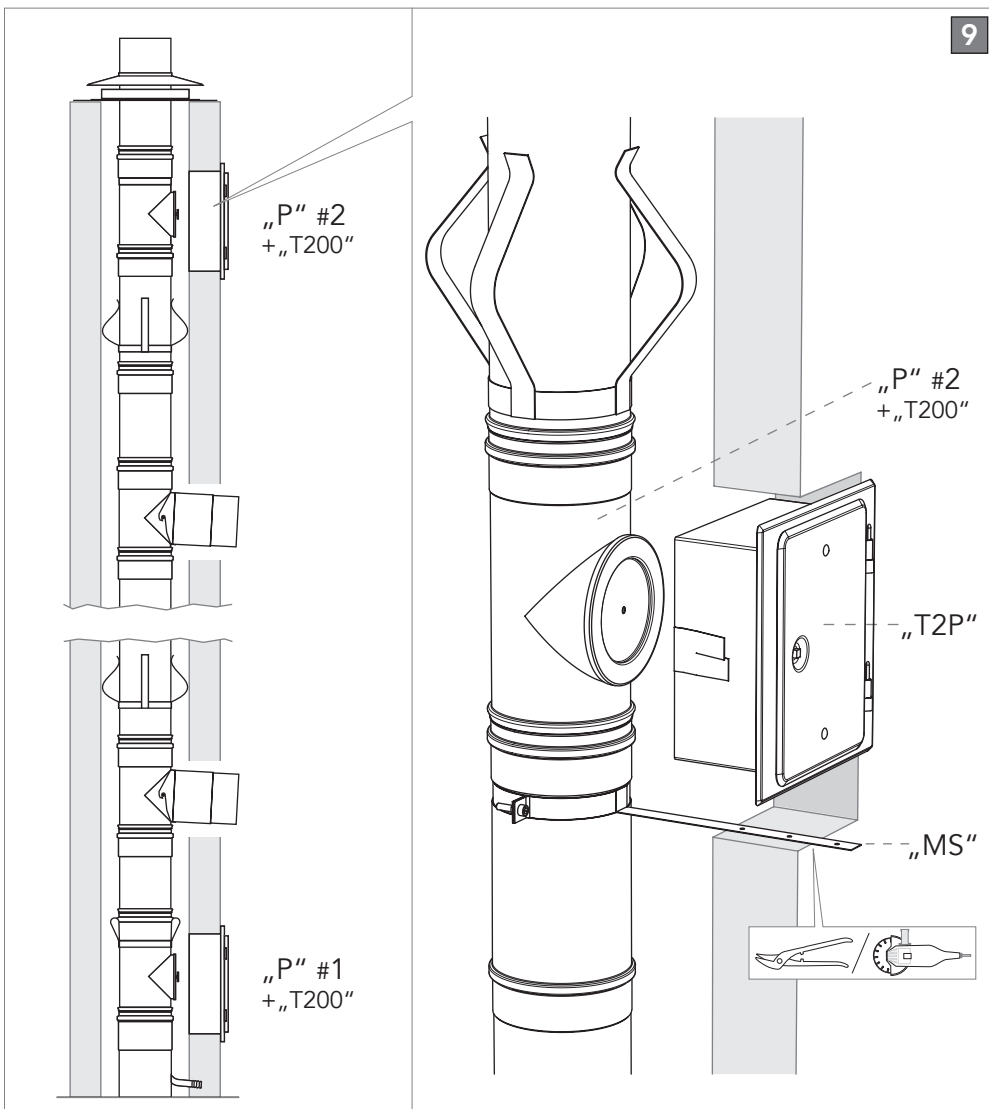
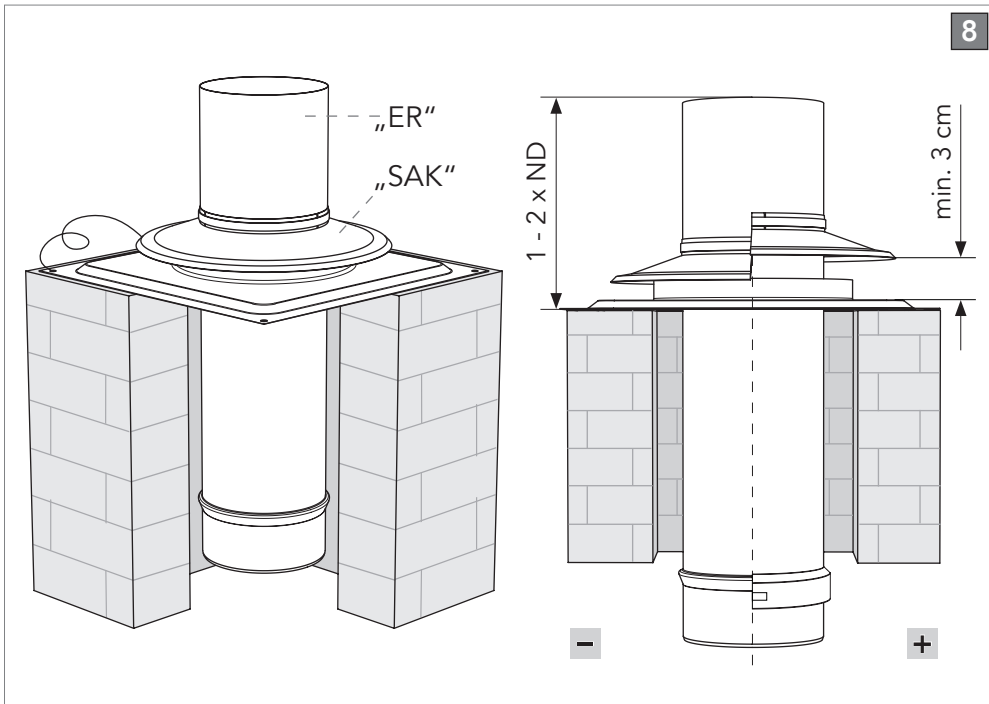

 UNITEC V2 

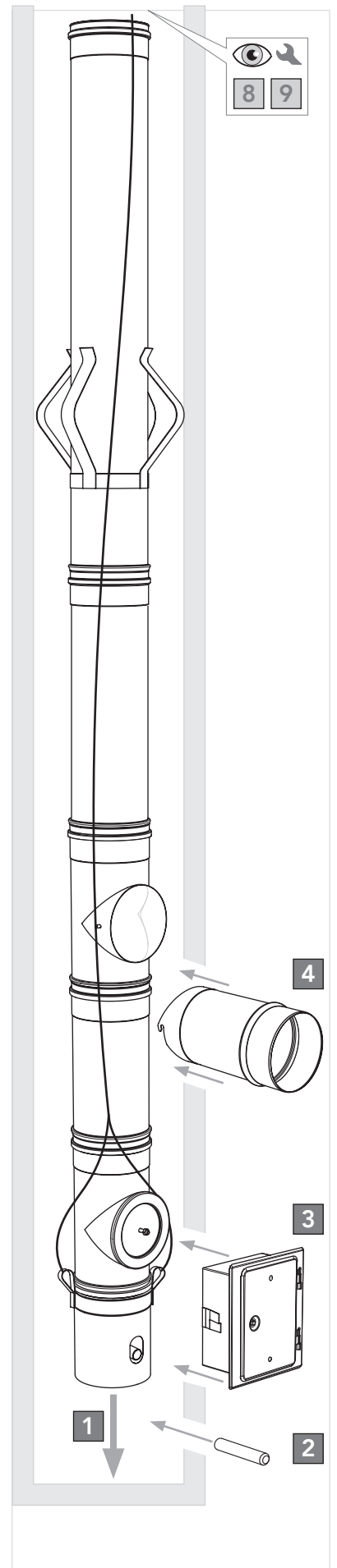

UNITEC -

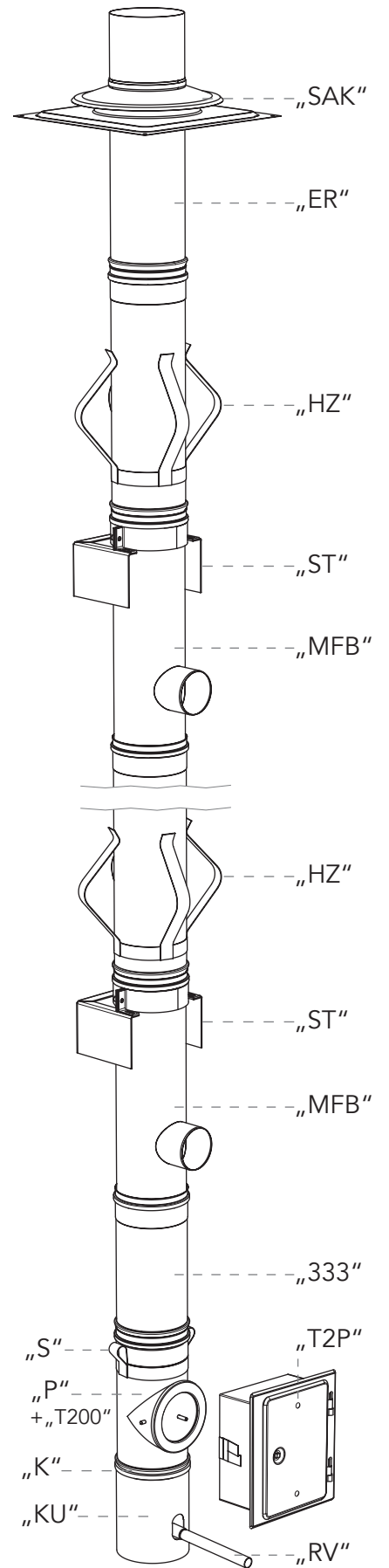
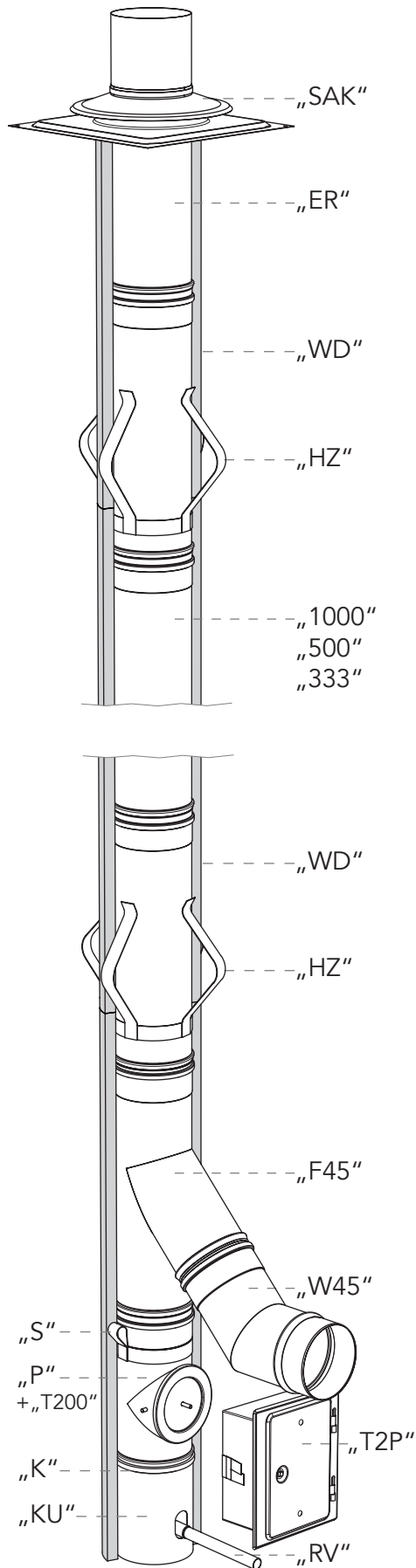
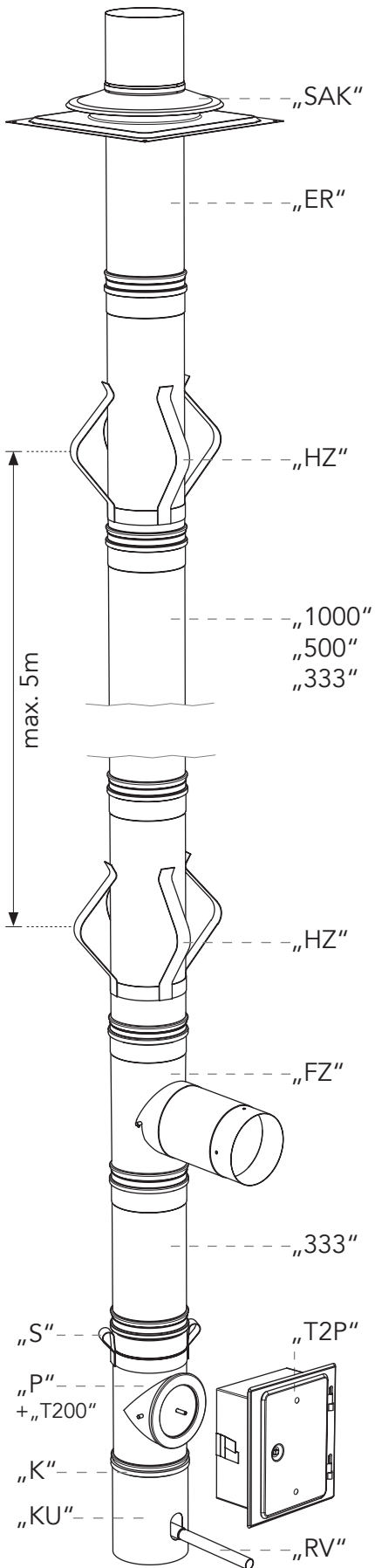

UNITEC 2x „W0-30“

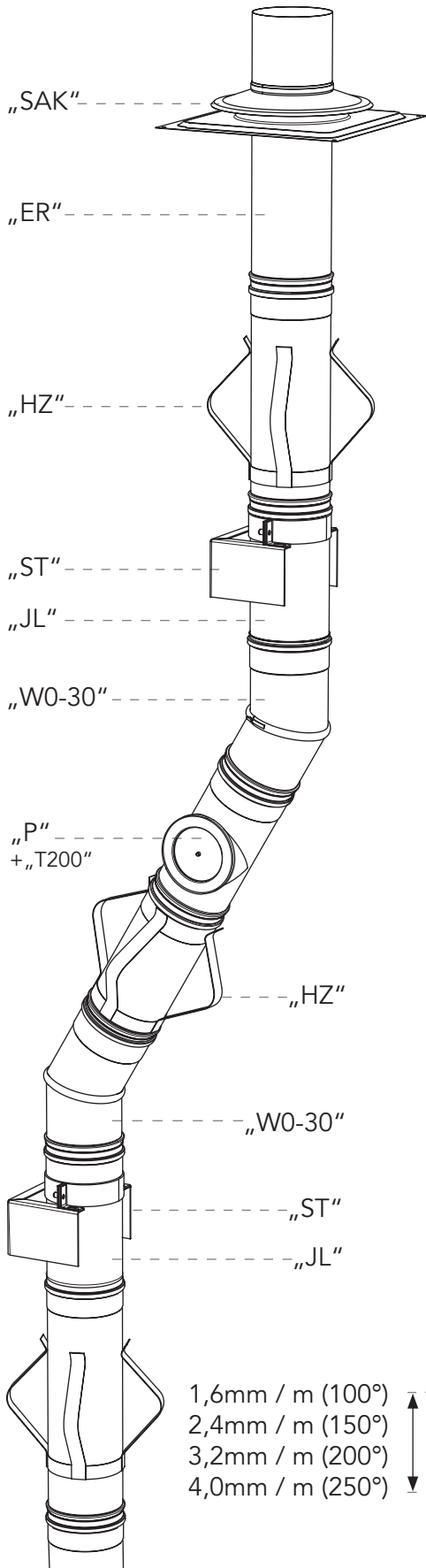

UNITEC + UNIFLEX

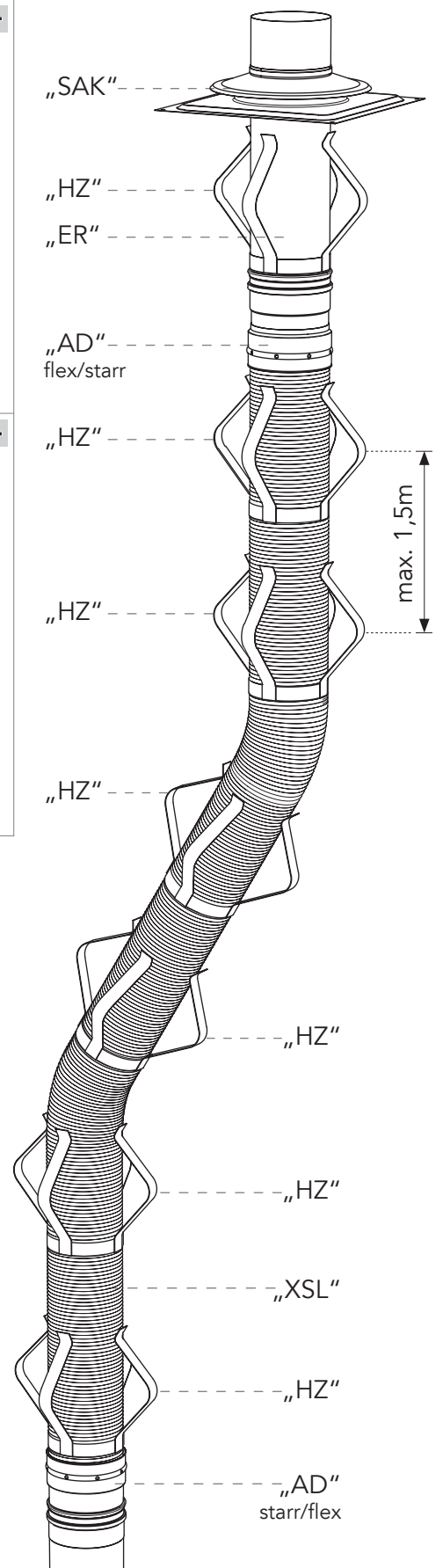
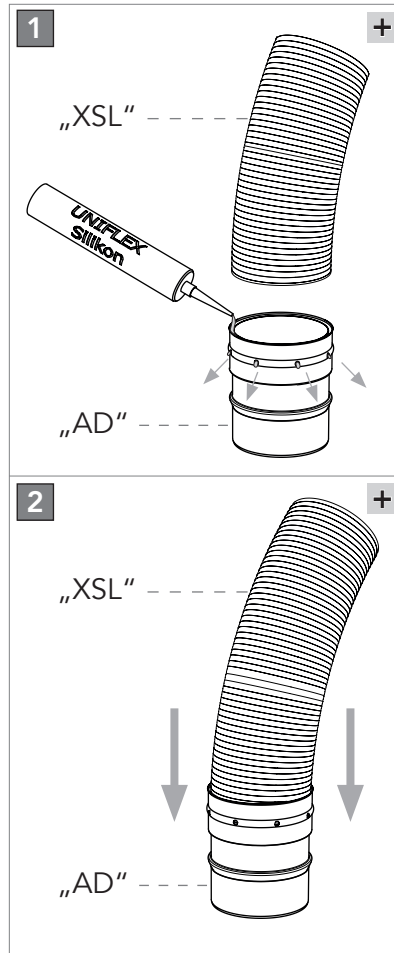

UNITEC +

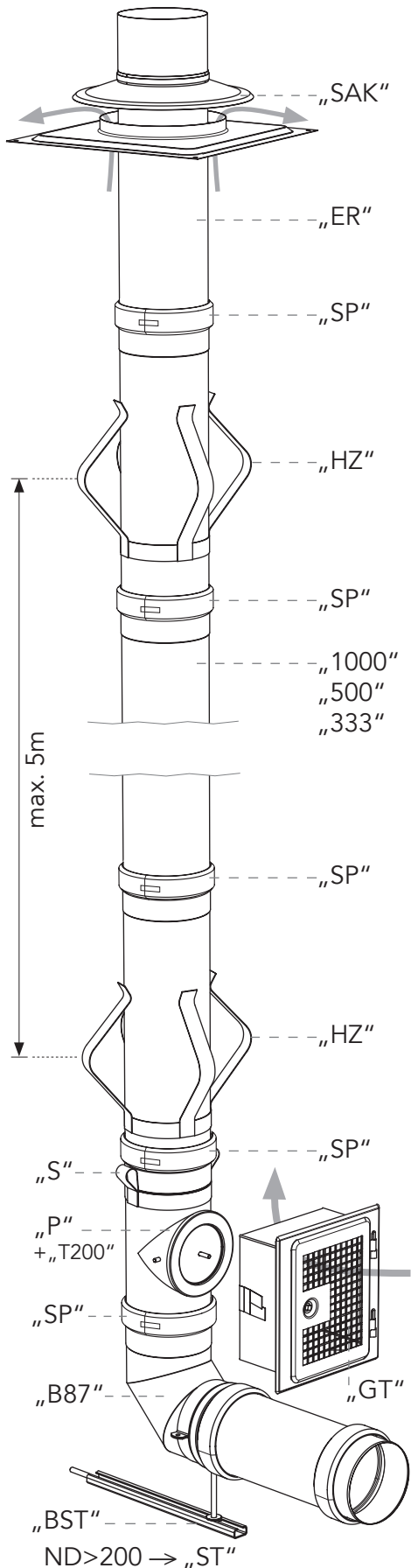

2x „BT90“

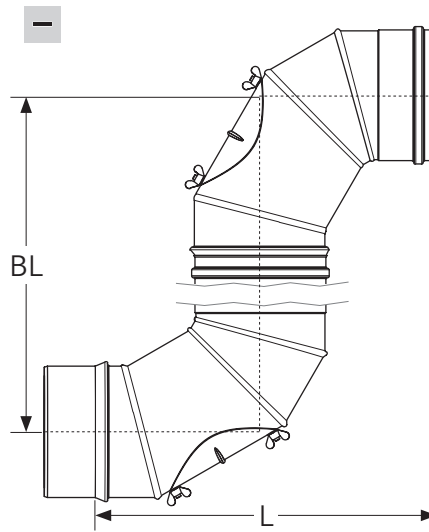

ND	BL = L
80	---
113	444
120	444
130	434
150	452
180	489
200	---
250	---
300	---
350	---
400	---
500	---
600	---

2x „BT87“

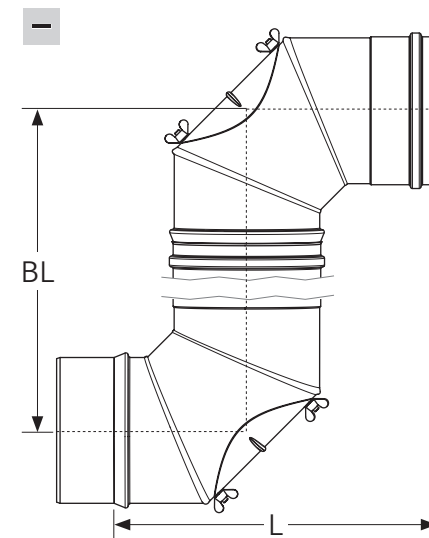

ND	BL = L
80	---
113	---
120	---
130	---
150	---
180	377
200	395
250	443
300	---
350	---
400	---
500	---
600	---

„B87“ + „PB87“

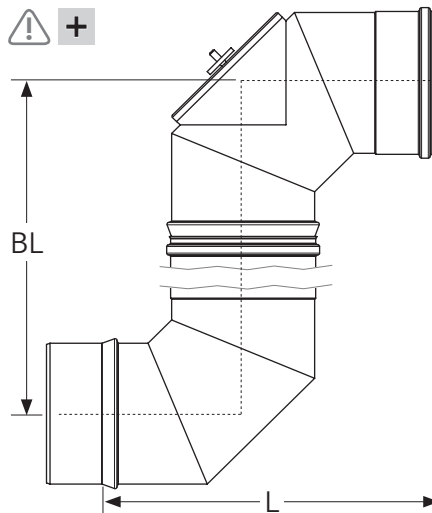

ND	BL = L
80	331
113	387
120	391
130	389
150	396
180	435
200	453
250	503
300	549
350	597
400	655
500	749
600	794

2x „W15“ $\sphericalangle = 15^\circ$

- +

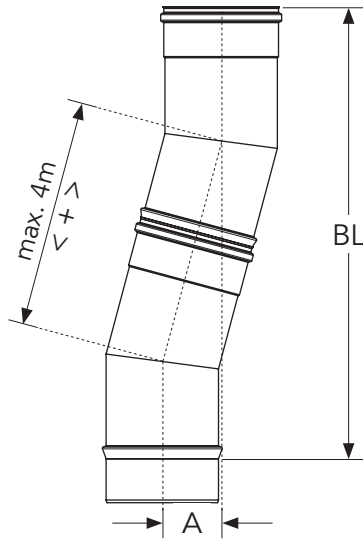
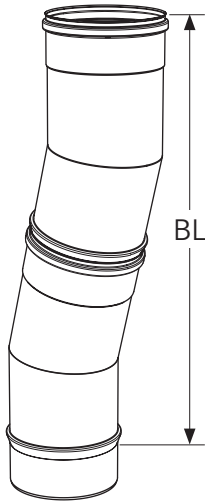

ND	BL	A	<+>
80-200	497	65	„W15“
250-600	824	108	„W15“
80-200	756	135	„W15“
250-600	1083	178	+ „333“
80-200	918	178	„W15“
250-600	1244	221	+ „500“
80-200	1401	307	„W15“
250-600	1727	350	+ „1000“
80-200	756	135	„W15“
250-600	1083	178	+ „P“

2x „W30“ $\sphericalangle = 30^\circ$

- +

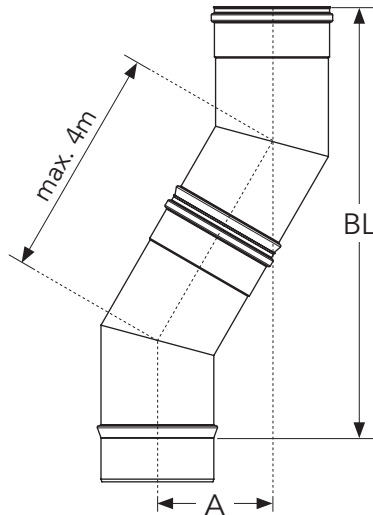
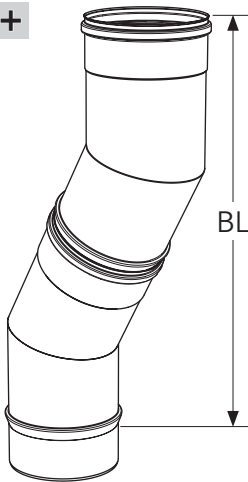

ND	BL	A	<+>
80-200	485	130	„W30“
250-600	795	213	„W30“
80-200	713	262	„W30“
250-600	1023	345	+ „333“
80-200	858	345	„W30“
250-600	1167	428	+ „500“
80-200	1291	595	„W30“
250-600	1600	678	+ „1000“
80-200	858	345	„W30“
250-600	1167	428	+ „P“

2x „W45“ $\sphericalangle = 45^\circ$

! +

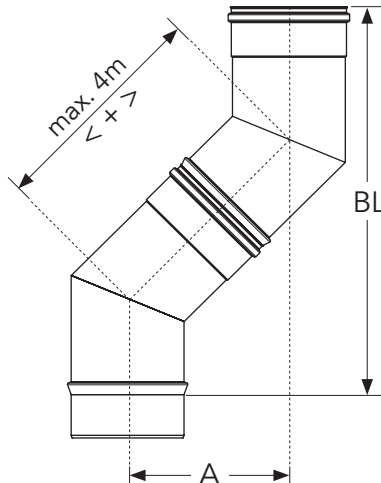
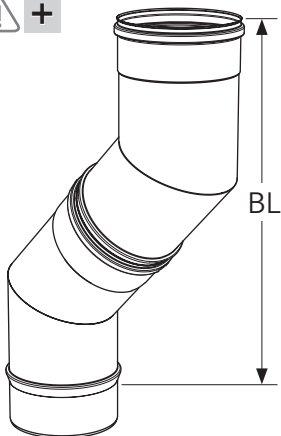

ND	BL	A	<+>
80-200	444	184	„W45“
250-600	727	301	„W45“
80-200	630	370	„W45“
250-600	913	487	+ „333“
80-200	748	488	„W45“
250-600	1031	605	+ „500“
80-200	1101	841	„W45“
250-600	1385	959	+ „1000“
80-200	748	488	„W45“
250-600	1031	605	+ „P“

„FZ“/ „FD“ („P“ „K“ „KU“ „RV“)

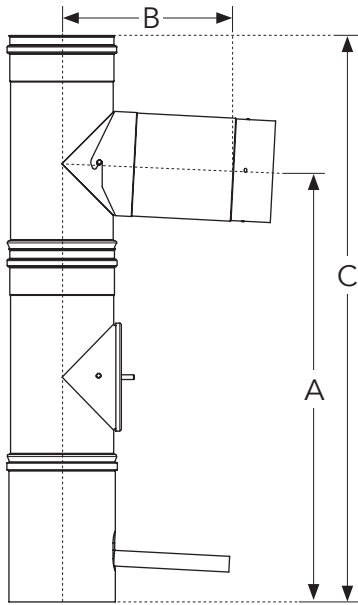

ND	A	B	C
113	555	269	725
120	555	272	725
130	555	277	725
150	555	287	725
180	638	302	829
200	638	312	829
250	638	337	829
300	734	362	1062
350	734	387	1062
400	764	412	1146
500	764	462	1146
600	884	512	1392

ND / A / B / C = „mm“ (+/-3mm)

„F45“ + „W45“ („P“ „K“ „KU“ „RV“)

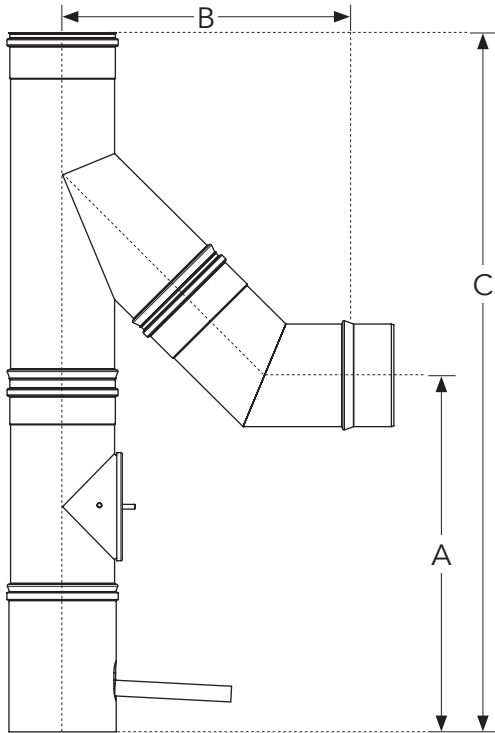

ND	A	B	C
113	468	338	892
120	461	345	892
130	458	356	892
150	456	370	892
180	441	398	892
200	433	416	892
250	517	593	1142
300	471	632	1142
350	443	658	1142
400	550	727	1392
500	519	809	1392
600	477	901	1392

ND / A / B / C = „mm“ (+/-3mm)

ND 500 & ND600 => „F60“ + „W30“

„RF“ (ND 1 > ND 2) -

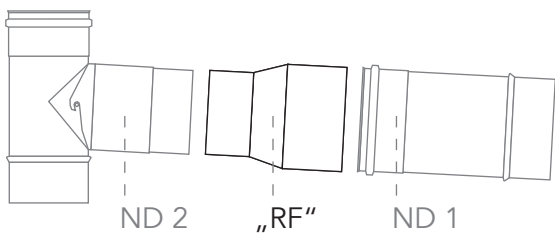

„EW“ (ND 1 < ND 2) -

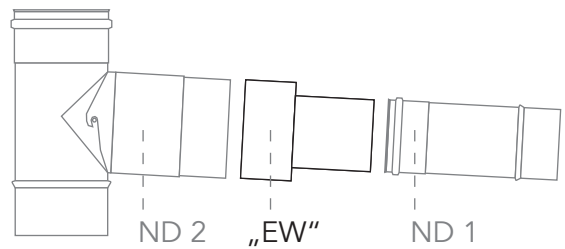

UNITEC - +

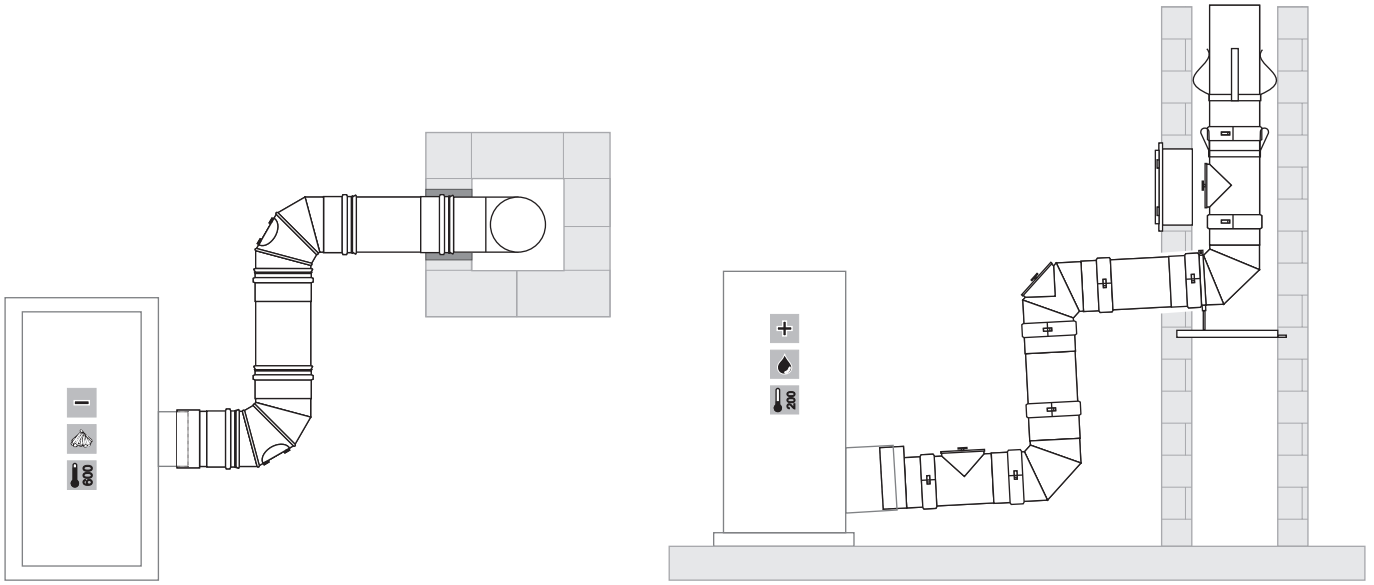

„KB“

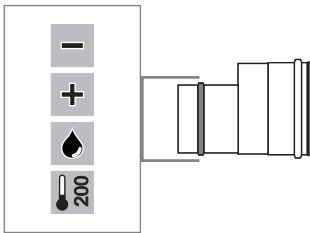

„KE“

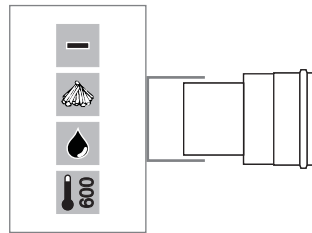

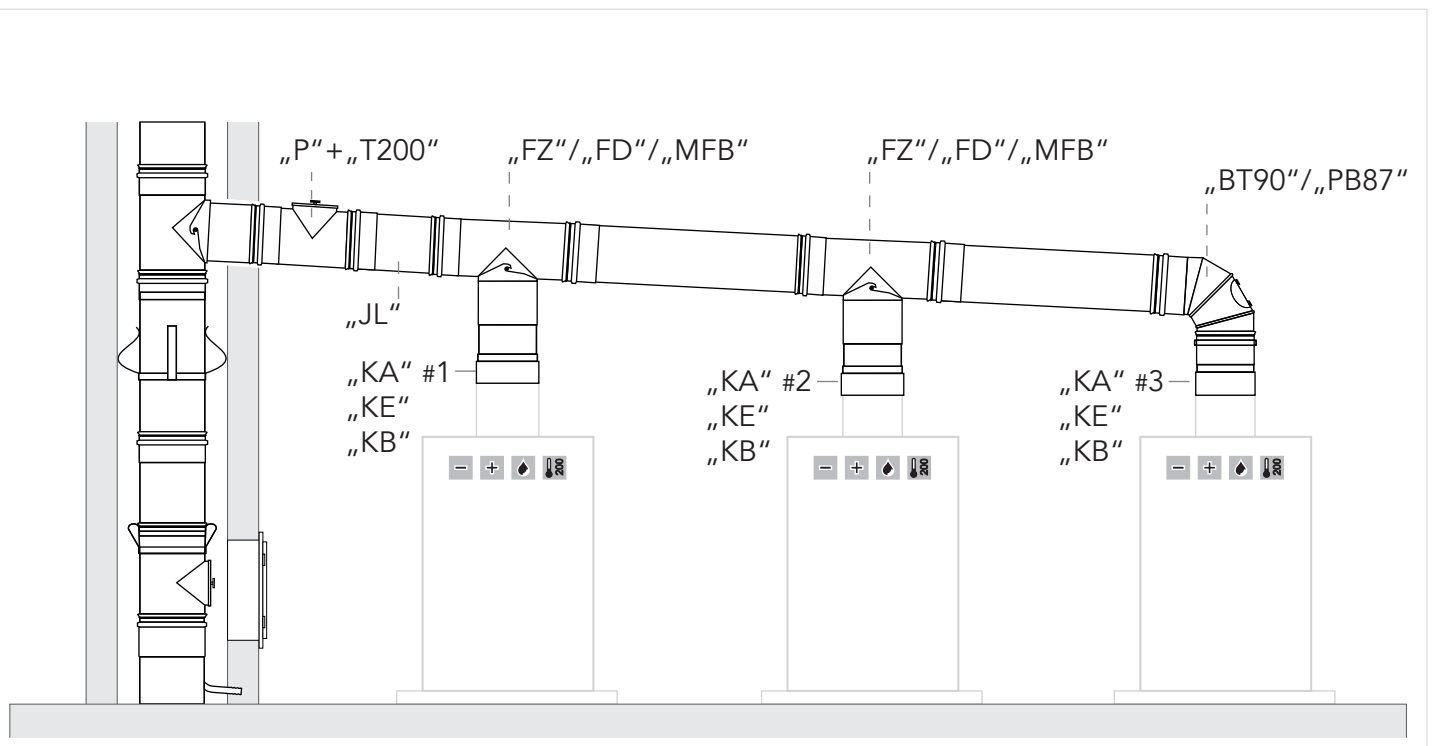
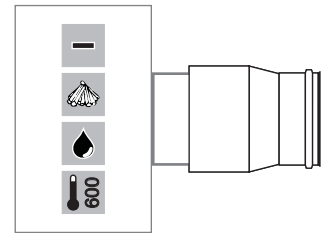

„KA“

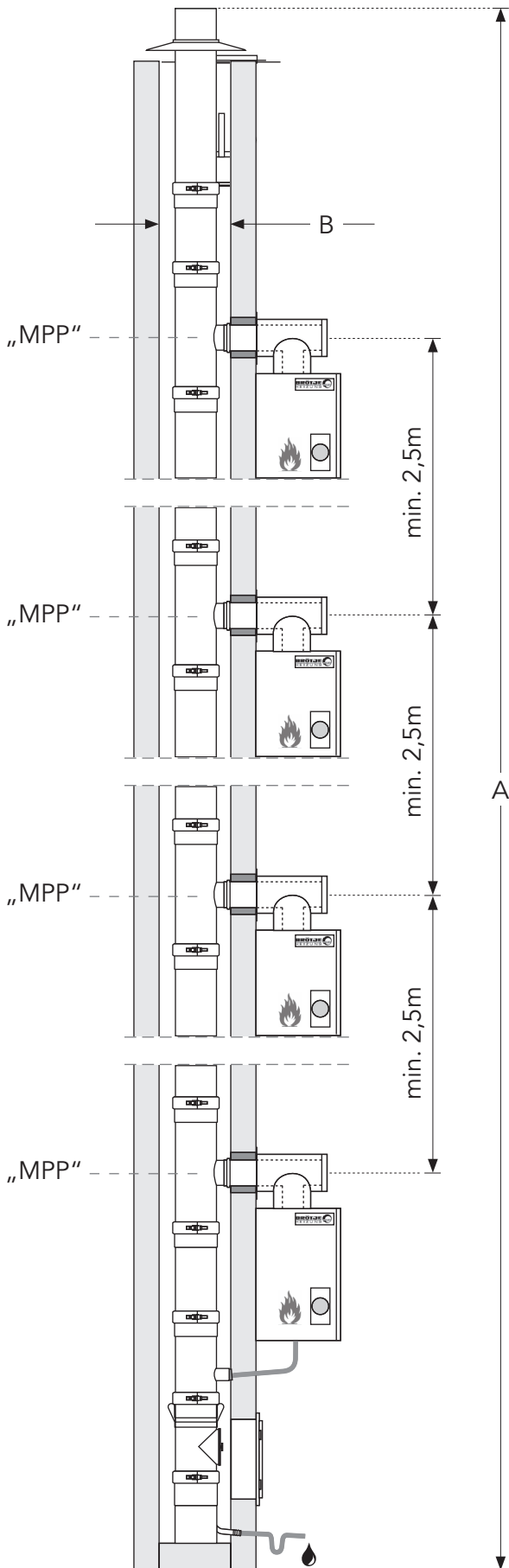

UNITEC + (4x „MPP“ + Brötje)



# 	max. KW	ND			max. A
2	40	113	180x180	190	20
2	56	113	180x180	190	12
3	60	113	180x180	190	13
3	70	113	180x180	190	11
3	80	113	180x180	190	9
3	80	113	200x200	200	16
3	84	113	200x200	200	15
4	60	113	180x180	190	15
4	65	113	180x180	190	14
4	70	113	180x180	190	13
4	75	113	180x180	190	12
4	80	113	200x200	210	18
4	90	113	200x200	210	16
4	96	130	200x200	210	15
4	96	130	225x225	240	20
	kW	mm	mm	mm	m

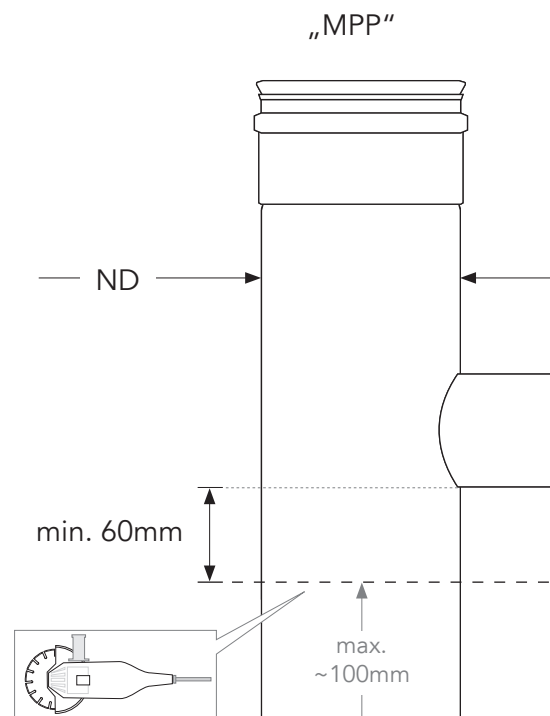

UNITEC (+ UNITHERM )

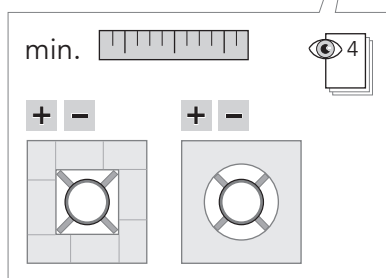
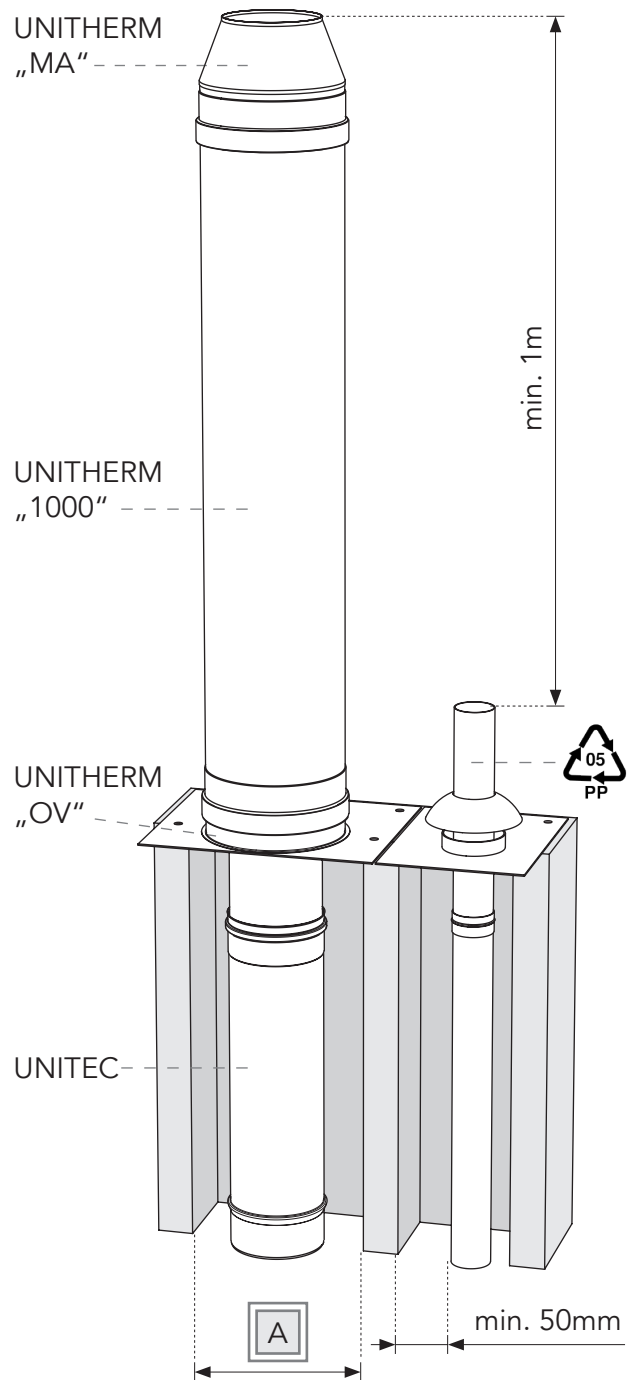
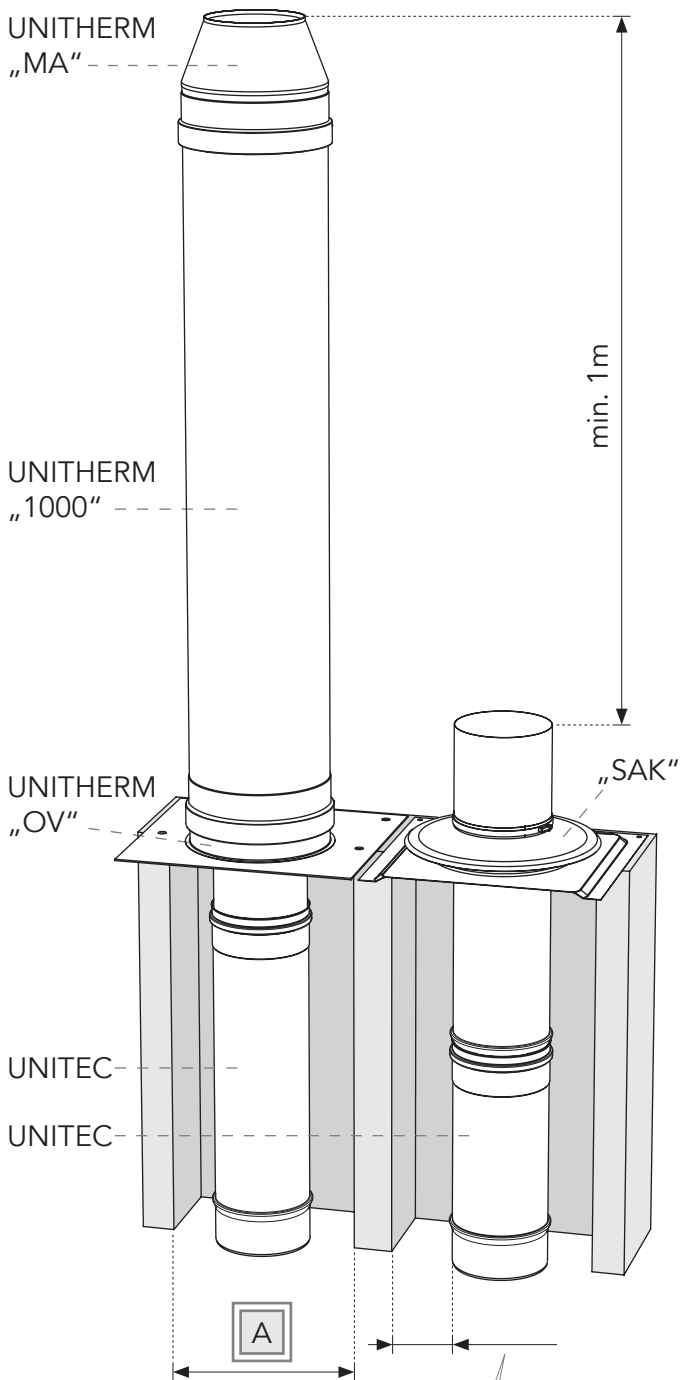

	ND UNITHERM
140x140	ø130mm
160x160	ø150mm
180x180	ø180mm
200x200	ø200mm



VOGEL&NOOT

Rettig Germany GmbH, Werk Lilienthal, Scheeren 8, 28865 Lilienthal
T: +49 4298919-0, F: -191, lilienthal@vogelundnoot.com, www.vogelundnoot.com

P18M1002 . 5000 . 09/13 BD

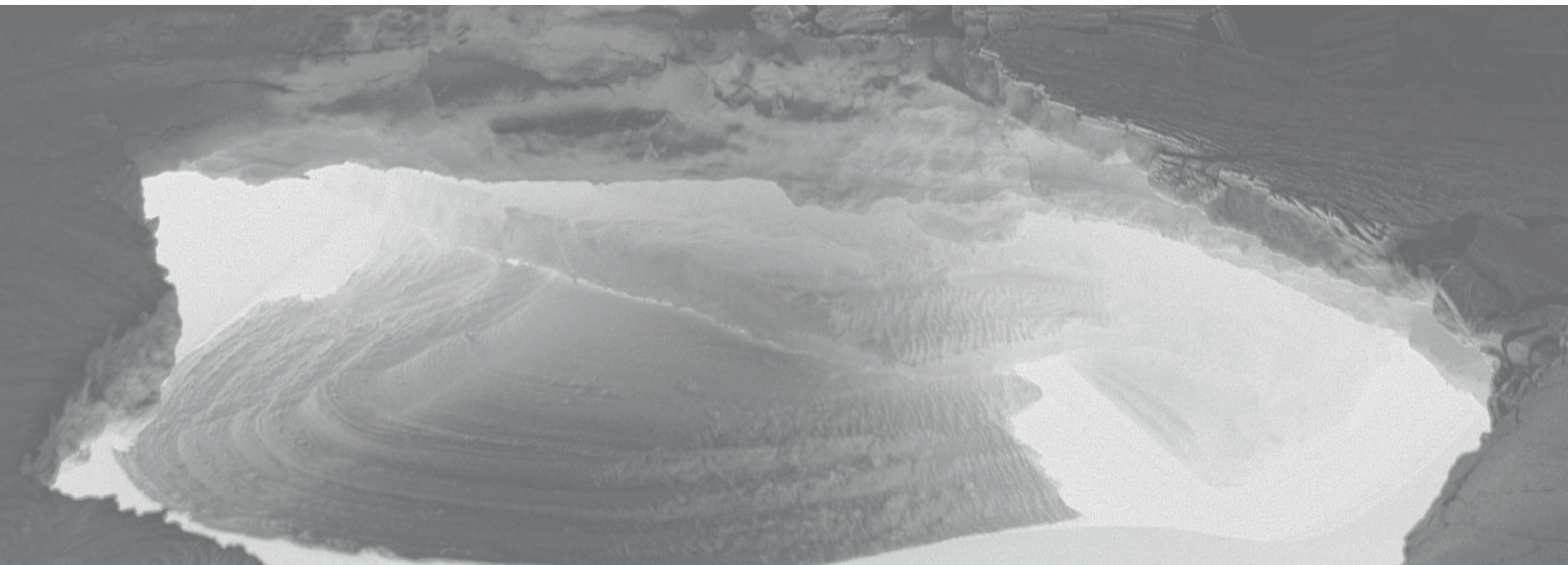

heatingthrough**innovation.**