





Benefits

- 3 basic types FMK, F1T and F1P
- Standard design with or without a fan, for two-pipe system
- An unlimited number of non-standard designs (non-standard lengths)
- Trench design without frame; trench design with a U-frame, which obscures the convector trench from view; trench design with an L-frame or Z-frame, which covers the gap between the trench and the floor
- Removable, accessible roll-up grille or rigid linear grille made from anodised aluminium, stainless steel, beech or oak. The wood grilles are treated with oil as standard. The aluminium grille is available in various shades: natural, black, or light or dark bronze
- Black-coated components such as the trench, cover and convection plates ensure that they integrate harmoniously with the look of the room
- The cover plate, which protects the trench during transport and installation, is included in the delivery
- A universal option for installation in living areas, hotels, administrative buildings, shopping centres, airport concourses, motor showrooms, conservatories or swimming pools, to name but a few
- **VOGEL&NOOT** provides its customers with reputable brands that offer the highest standards of quality. The production processes at all of our production sites are ISO-certified. The quality and performance specifications of our underfloor convectors are tested by recognised European institutes. The requirements that these quality hallmarks require us to achieve are there to ensure that the products we supply offer are safe, provide the best heating performance and are of the highest quality
- Easy installation and uninstallation of the heat exchangers and fans
- Safe, low voltage of fan power units (12V)
- Increased performance, extended service life, minimal noise level, reduced electricity consumption and therefore reduced operating costs thanks to the new EC motors

VOGEL&NOOT



Key

-  Heating function
-  Natural convection
-  Forced convection
-  Connection to the two-pipe distribution



ULOW-E2

Profile panel radiators

Plan panel radiators

Vertical radiators



General information

Preformed plate system

Stapler system

Special systems



Bathroom radiators

Design radiators



Standard Column radiators

Centrally connected Column radiators

Architecture Column radiators



VONARIS

VONARIS-M

KONTEC

INTRATHERM



FMK 319

Trench convector with natural convection (without a fan), noiseless operation. The convection plates increase heat output and increase safety when cleaning the convectors. This model is intended for heating.



F1T 323

Trench convector with forced convection (12 V EC cross-flow fan). This variant provides the solution where the FMK is no longer sufficient. This model is also intended for heating.



F1P 328

Trench convector with even more powerful forced convection (12 V EC tangential fan), which guarantees even faster delivery of heat. This variant is available for situations requiring a level of performance that exceeds that of the F1T.



Individual heat exchanger – the simplest solution 332

In view of various individual requirements expressed by our customers, we have expanded our product range to include individual heat exchangers that are installed in the Intratherm Trench convectors as standard. The individually installed heat exchangers are suitable for use in reconstructions of cellars, loft spaces or attics, as well as for installation in window sills or for installation in channels or gutters. Brackets for the installation of heat exchangers in floors or in the wall are also supplied as accessories with the heat exchangers.

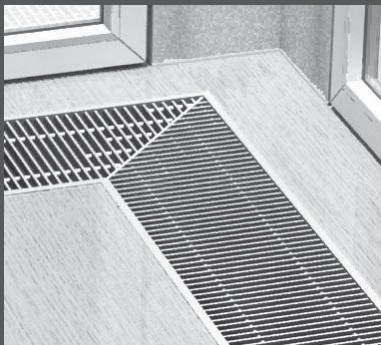

Grilles

336

The cover grilles are practically the only visible part of the floor convectors and for this reason a great deal of attention is paid to the material and the finish of the grilles. Apart from this design aspect, the cover grille also performs technical functions – namely accessibility and distribution. The cover grille ensures even load-bearing, which is spread over the edges of the trench onto the base, while at the same time the shape of the bars determines the air flow.

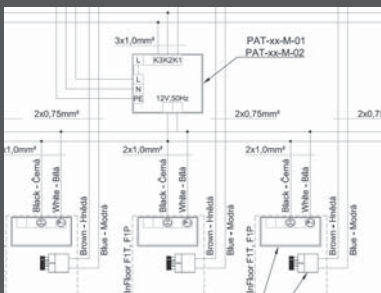

Control, illustrated by circuit diagrams

340

The heat output of the convector can be controlled either by hot water or by air (only in the design with a fan). Quantitative control of the hot water takes place via the thermostatic valve lift (thermostatic head controlled by remote control setting or adjusting drive of the room thermostat). Control by means of air (F1T and F1P) is effected by the fan revolution speed. The speed of revolutions can be controlled manually or automatically using a room thermostat.



Installation of the Trench convector (instruction sheet)

355

The optimum functioning of the convector depends, of course, on its installation. In order to ensure problem-free operation, it is essential that the system is set correctly and fixed properly to the base. The convectors can be embedded fully in concrete or fixed mechanically in the raised floor.

Conversion Table	352
Pressure loss diagram	353

Introduction

The Trench convectors from **VOGEL&NOOT** offer the optimum system-based solution for areas in which the conventional radiator is undesirable for aesthetic reasons or due to space constraints. The Trench convectors are intended for use in hidden installations that are integrated into the floor. In many settings, such as conservatories, entrances and office or administrative buildings, more stringent requirements are set with regard to appearance. Thanks to the efficient, low-noise fans, the convectors are able to provide high performance at minimum depths (at least 90 mm) and are therefore ideally suitable for inclusion in renovation works and new-build projects alike. Removable, walkable grilles in a variety of shapes, materials and shades provide a cover for an efficient copper/aluminium heat exchanger (with or without a fan) located in the convector trench.

With a variety of heights, lengths, depths and a number of power variants, the Intratherm series offers the most effective solution, whatever the layout. The fully rust-proof copper-aluminium heat exchanger responds rapidly to the different temperature requirements in the room. The Trench convector counteracts the uncomfortable influx of cold air next to glazed walls, therefore effectively preventing the intrusion of cold air into the room and promoting air circulation even in large rooms.

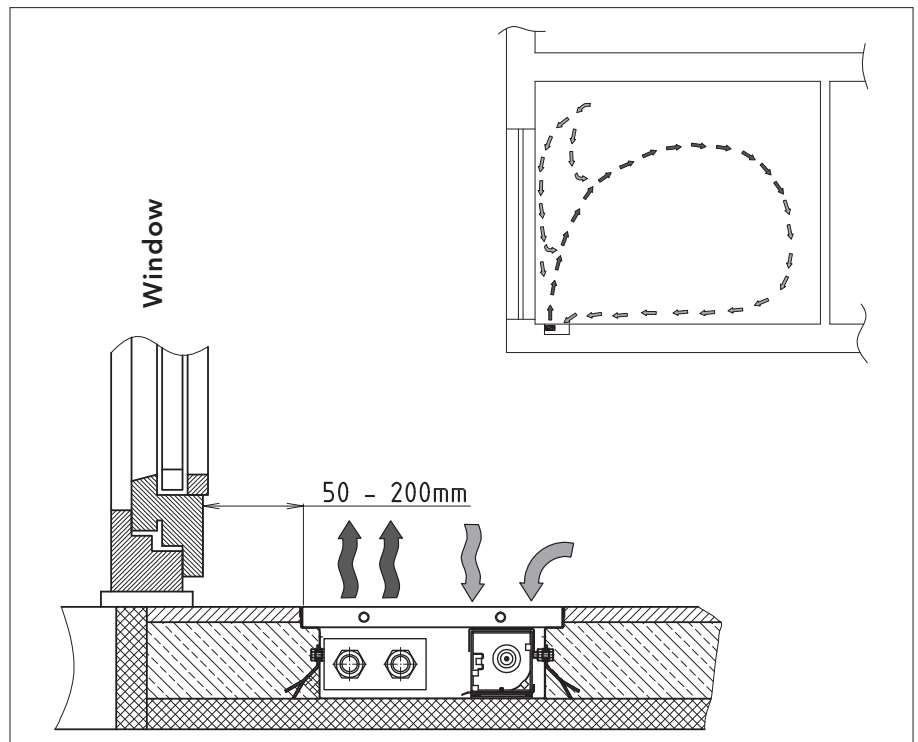

The positioning of the heat exchanger on the window side is a common variant that ensures even circulation of air within the entire room.

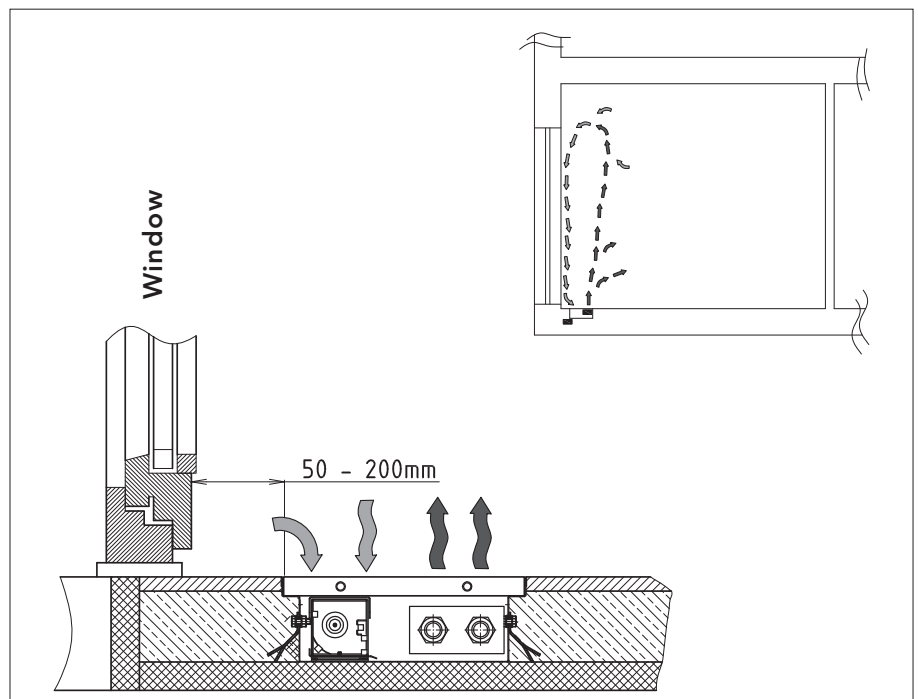

The positioning of the heat exchanger of the convector towards the centre of the room ensures the function of a 'heat barrier' so that cold air close to the window is screened off.

INTRATHERM FMK.

Fan-less convectors that provide natural convection



Imagine a simple, economical and entirely low-noise variant with minimal operating costs. The FMK convectors contain no fan and are intended for heating, based on the principle of free convection by natural air circulation. The heat output of the convector is controlled by a thermostatic valve, which in turn is operated by an adjusting drive (possibly in the form of thermostatic heads that can be set remotely).

- 3 standard heights (90, 110 and 140 mm)
- 5 standard widths (180, 260, 290, 340 and 420 mm)
- Lengths: from 800 mm

Technical specification:

- Heat output, measured in accordance with EN 442
- Test overpressure 13 bar
- Max. operating overpressure 10 bar
- Maximum operating temperature 110 °C

DIN EN **442**

EN ISO 9001

CE

EN 442
N
GEPRÜFT

55
45
DIE neue WÄRME

Guarantee statements are available to download at www.vogelundnoot/download

Intratherm FMK – Fan-less convectors that provide natural convection

Intratherm FMK standard delivery includes:

- A convector trench that is galvanized on both sides and is coated in RAL 9005 Black paint.
- A trench with universally insertable heat exchanger supports, which enable the convector to be connected from the right and the left
- Front and side components of the trench with perforations for the water connection and feeding the cable, enabling the heat exchanger to be connected from the right and the left
- Fully corrosion-proof copper/aluminium heat exchanger with minimal water content, with air vent, coated in RAL 9005 Black
- A pair of convective plates to increase heat output and safety during maintenance
- Cover plate for the water connection
- All trench components coated in RAL 9005 Black as standard
- Wooden cover plate, which protects the convector trench and the heat exchanger during transport and installation
- Accessories supplied as standard: setting screws M8 x 30 for setting the position of the trench, floor screed anchors for the fixing of the trench into concrete, rubber bushings for the perforations, flexible stainless steel connecting hoses with seal, anchor brackets for setting the trench height
- Impact-noise insulation between the grille and the trench

Extras:

- Trench made from brushed stainless steel plate
- Accessories: thermostatic valve, lockshield valve, thermostatic head with remote controller, adjusting drive, room thermostat
- Insulation of the trench floor, three-sided insulation of the trench
- Coatings for the trench, heat exchanger and other components in a different RAL colour



Construction of the Intratherm FMK Trench convector

FMK 260 x 1250 x 90 mm with an aluminium roll-up grille and U-frame

FMK 260 x 1250 x 140 mm with an aluminium linear grille and Z-frame

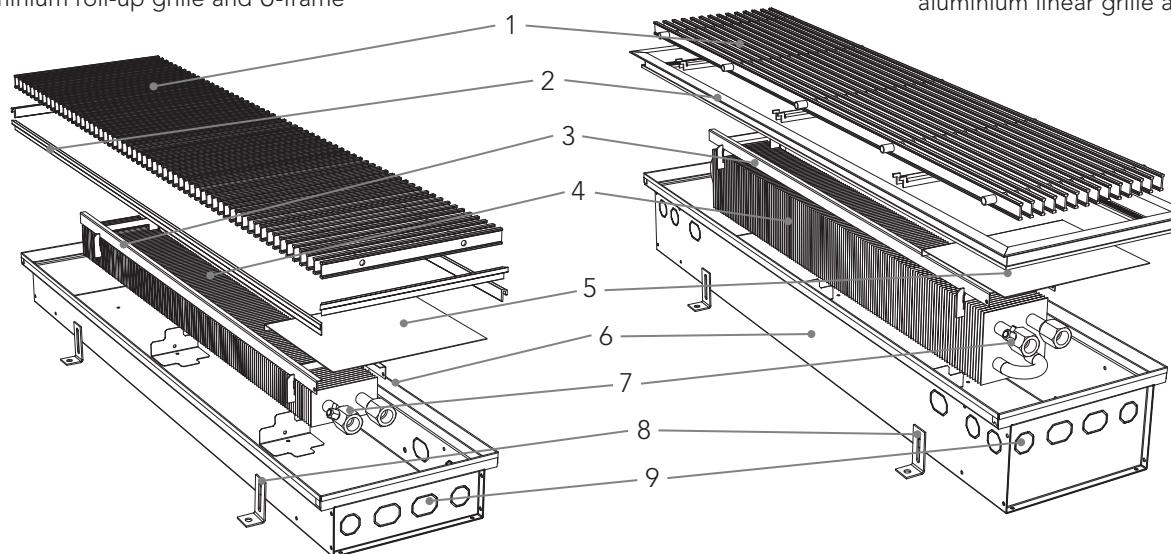

Key

- | | |
|-----------------------------------|------------------------------|
| 1 Roll-up grille or linear grille | 6 Convector trench |
| 2 Frame (O, U, L, Z) | 7 Air vent |
| 3 Convection plate | 8 Adjustable anchor brackets |
| 4 Fins of heat exchanger | 9 Perforations |
| 5 Cover plate | |

Due to the nature of their construction, linear grilles are only suitable for the heights 110 mm and 140 mm.

Outputs

Intratherm FMK galvanized – outputs

- Convector lengths are available accurate to within 1 cm
- Lengths over 5 m available upon request

Width (mm)	180			260			290			340			420		
↑ ↓ Height (mm)	90	110	140	90	110	140	90	110	140	90	110	140	90	110	140
↔ Length (mm)	Heat output [W] at 75/65/20 °C														
750	116	134	147	152	179	220	156	199	242	201	237	306	253	290	360
900	150	173	190	196	231	285	201	257	313	260	306	397	327	376	466
1000	173	199	219	226	266	328	232	296	361	299	353	457	376	432	537
1100	196	225	248	256	301	371	263	335	408	338	399	517	426	489	607
1200	219	251	277	285	336	414	293	374	456	378	446	577	476	546	678
1250	230	264	291	300	354	436	308	393	480	397	469	607	500	575	713
1300	242	278	305	315	371	458	324	413	503	417	492	637	525	603	749
1400	264	304	334	345	406	501	354	452	551	456	539	697	575	660	819
1500	287	330	363	374	441	544	385	491	598	496	585	757	624	717	890
1700	333	382	421	434	512	630	446	569	693	574	678	877	723	831	1031
1750	344	395	435	449	529	652	461	588	717	594	701	907	748	859	1066
1900	378	435	478	493	582	717	507	647	788	653	771	997	822	945	1172
2000	401	461	507	523	617	760	537	685	836	692	817	1058	872	1002	1243
2100	424	487	536	553	652	803	568	724	883	732	864	1118	921	1058	1313
2250	458	526	579	597	704	868	614	783	955	791	933	1208	996	1144	1419
2300	470	539	594	612	722	889	629	802	978	810	957	1238	1020	1172	1455
2500	515	592	651	672	792	976	690	880	1073	889	1049	1358	1120	1286	1596
2700	561	644	709	731	862	1062	751	958	1168	968	1142	1478	1219	1400	1737
2750	572	657	723	746	879	1084	766	978	1192	987	1166	1508	1243	1428	1772
2900	606	697	767	790	932	1148	812	1036	1263	1046	1235	1598	1318	1514	1878
3000	629	723	795	820	967	1192	843	1075	1311	1086	1282	1658	1367	1571	1949
3100	652	749	824	850	1002	1235	873	1114	1358	1125	1328	1719	1417	1628	2020
3250	686	788	867	894	1055	1300	919	1172	1429	1184	1398	1809	1491	1713	2125
3300	698	801	882	909	1072	1321	934	1192	1453	1204	1421	1839	1516	1741	2161
3500	743	854	939	969	1142	1407	995	1270	1548	1282	1514	1959	1615	1855	2302
3700	789	906	997	1028	1212	1494	1056	1348	1643	1361	1607	2079	1714	1969	2443
3750	812	932	1026	1058	1247	1537	1087	1387	1691	1400	1653	2139	1764	2026	2514
3900	834	958	1055	1088	1282	1580	1117	1425	1738	1440	1700	2199	1813	2083	2584
4000	857	985	1083	1117	1317	1623	1148	1464	1786	1479	1746	2259	1863	2140	2655
4100	880	1011	1112	1147	1352	1666	1178	1503	1833	1519	1792	2319	1912	2197	2726
4250	926	1063	1170	1207	1422	1753	1239	1581	1928	1597	1885	2440	2011	2310	2867
4300	926	1063	1170	1207	1422	1753	1239	1581	1928	1597	1885	2440	2011	2310	2867
4500	971	1115	1228	1266	1493	1839	1300	1659	2023	1676	1978	2560	2110	2424	3008
4700	1017	1168	1285	1325	1563	1926	1361	1737	2118	1755	2071	2680	2209	2538	3149
4750	1040	1194	1314	1355	1598	1969	1392	1776	2166	1794	2118	2740	2259	2595	3220
4900	1062	1220	1343	1385	1633	2012	1423	1815	2213	1833	2164	2800	2308	2652	3291
5000	1085	1246	1372	1415	1668	2055	1453	1854	2261	1873	2210	2860	2358	2709	3361

We reserve the right to amend typing errors and make technical changes. Valid from 1 February 2014.

Outputs for stainless steel and wooden grilles/weights and water capacity/dimensions/item numbers

Intratherm FMK – outputs for stainless steel and wooden grille

The maximum length of the convector is unlimited. Conveyors over 3500 mm in length can be created by fitting together multiple modules and feature at least two heat exchangers.

For heat output, measured in accordance with EN 442; coefficients for converting heat output – see page 352.

All heat outputs shown relate to the aluminium version. In the case of stainless steel and wooden grilles, the heat output value needs to be multiplied by a correction factor (see adjacent table).

Grille	Free cross-section (%)	Correction factor (-)
Aluminium	0,71	1,00
Wood	0,58	0,95
Stainless steel	0,58	0,95

Intratherm FMK – Weight and water capacity

Width (mm)	180			260			290			340			420		
	90	110	140	90	110	140	90	110	140	90	110	140	90	110	140
Height (mm)	5,9	6,1	7,8	6,4	6,7	8,4	6,9	7,1	8,8	8,0	8,3	10,8	9,9	10,2	14,1
Weight (kg/m)	0,3	0,3	0,7	0,3	0,3	0,7	0,3	0,3	0,7	0,4	0,4	1,0	0,7	0,7	1,4
Water capacity (l/m)															

Intratherm FMK – Dimensions

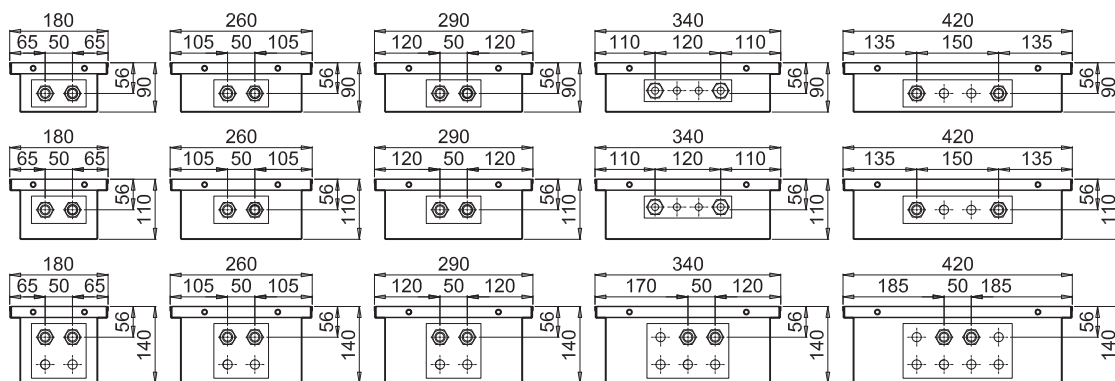

Connection from the left

Connection from the right

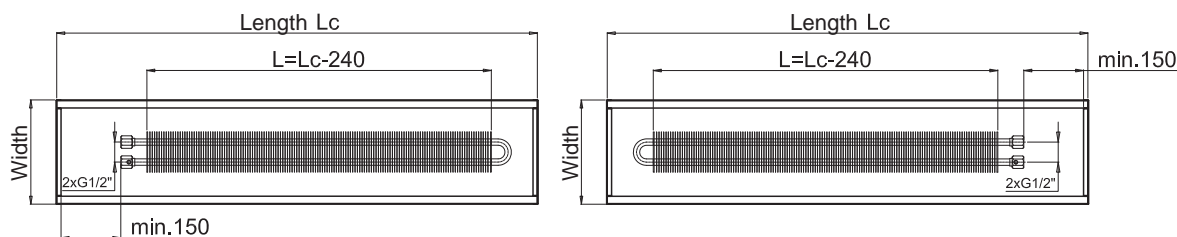

The convector connection can be selected at the installation site itself by turning the heat exchanger.

For details regarding control and the recommended circuit diagrams, see page 340.

For a choice of accessories, see price list on page 267.

Correction factor for conversion of heat output

For a table with correction factors for converting the heat output, see page 352.

Pressure losses

For diagrams of pressure losses of the heat exchanger for conveyors, see page 353.

INTRATHERM F1T.

Efficient basic version with 12 V cross-flow fan (EC motor) for heating

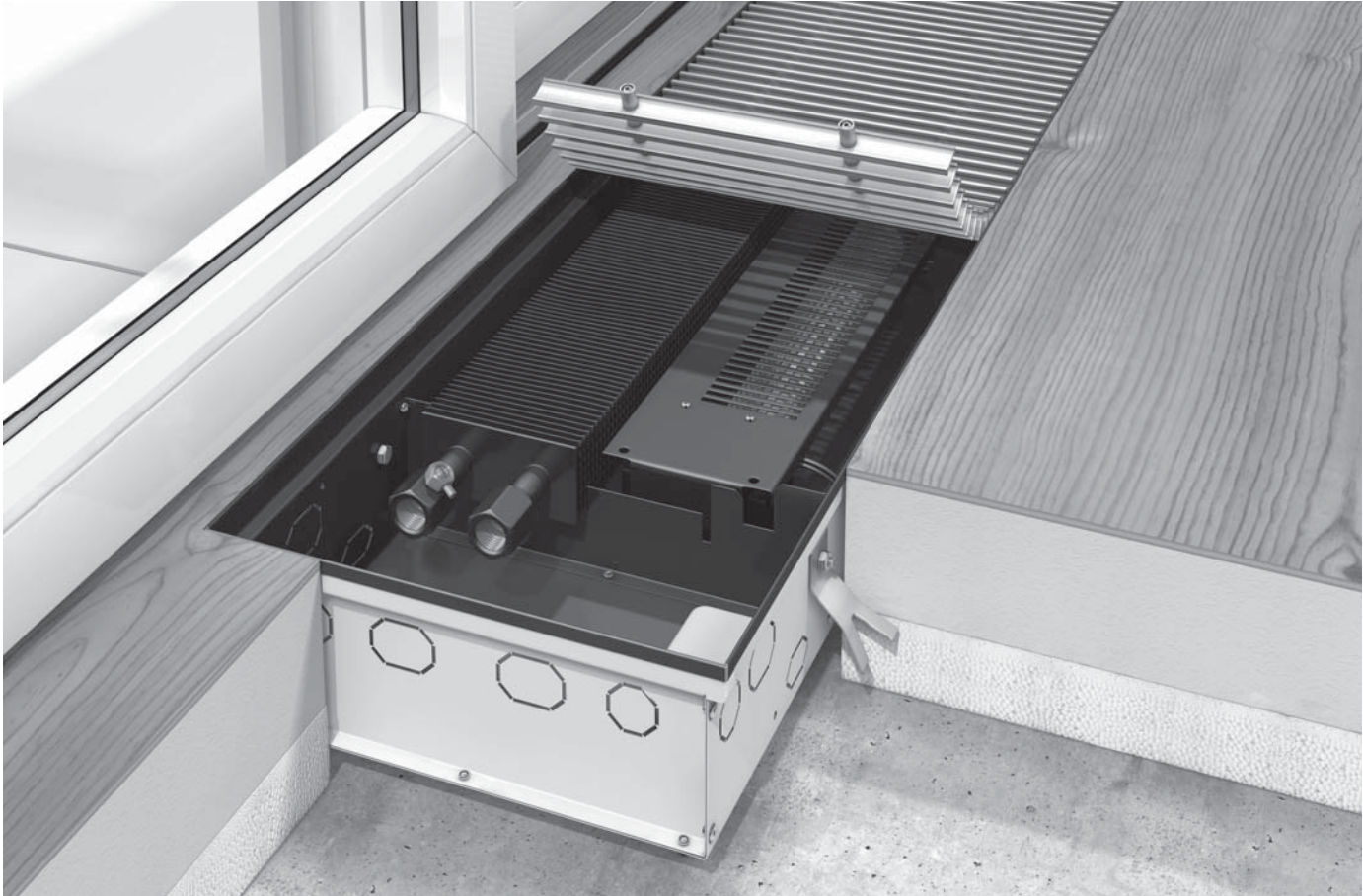

This new generation of Intratherm F1T Trench convectors succeeds the original series of FMT convectors with fans. It offers a cost-effective variant with increased heat output, reduced noise level and minimal operating costs. The length of the fan has been chosen in such a way that the largest possible area of the heat exchanger is supplied with air. The heat output of the convector can be controlled either by hot water or by the air from the fan. All fans are fitted with energy-saving 12 V EC motors.

- 2 standard heights (90 and 140 mm)
- 3 standard widths (260, 290 and 340 mm)
- Lengths from 800 mm

Technical specification:

- Heat output, measured in accordance with EN 442
- Test overpressure 13 bar
- Max. operating overpressure 10 bar
- Maximum operating pressure 110 °C

Benefits of the new technical solution

- Effective use of the space inside the trench
- Optimised length of fan relative to the heat exchanger
- Increase in heat output
- Reduction of the price of the convector, in relation to heat output
- Considerable reduction in electrical power used by the convector
- Considerable reduction in operating costs
- Reduction of the noise level



Guarantee statements are available to download at www.vogelundnoot/download

Intratherm F1T – efficient basic variant with 12V cross-flow fan (EC motor) for heating

Intratherm F1T standard delivery includes:

- A trench consisting of a plate galvanized on both sides and coated in RAL 9005 Black
- Front and side components of the trench with perforations for the water connection and feeding the cable, which enable the heat exchanger and fan to be connected from the right and the left
- Fully corrosion-proof copper/aluminium heat exchanger with minimal water content, with air vent, coated in RAL 9005 Black
- Cross-flow fan with 12 V EC motor
- EC fan drive with minimal electrical consumption
- Cover plate for the water connection
- All trench components coated in RAL 9005 Black as standard
- Wooden cover plate, which protects the trench, the heat exchanger and the fan during transport and installation
- Accessories supplied as standard: setting screws M8 x 30 for setting the position of the trench, floor screed anchors for the fixing of the trench into the concrete, rubber bushings for the perforations, flexible stainless steel connecting hoses with seal, anchor brackets for setting the trench height
- Impact-noise insulation between the grille and the trench

Extras:

- Trench made from brushed stainless steel plate
- Accessories: thermostatic valve, lockshield valve, thermostatic head with remote controller, adjusting drive, room thermostat with speed setting switch
- Insulation of the trench floor, three-sided insulation of the trench
- Coatings for the trench, heat exchanger and other components in a different RAL colour

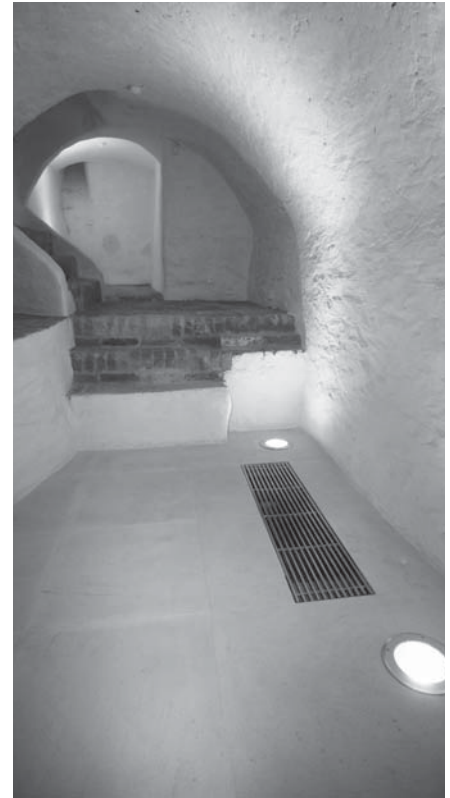

Construction of the Intratherm F1T Trench convector

F1T 260 x 1250 x 90 mm with an aluminium roll-up grille and Z-frame

F1T 260 x 1250 x 140 mm with an aluminium linear grille and L-frame

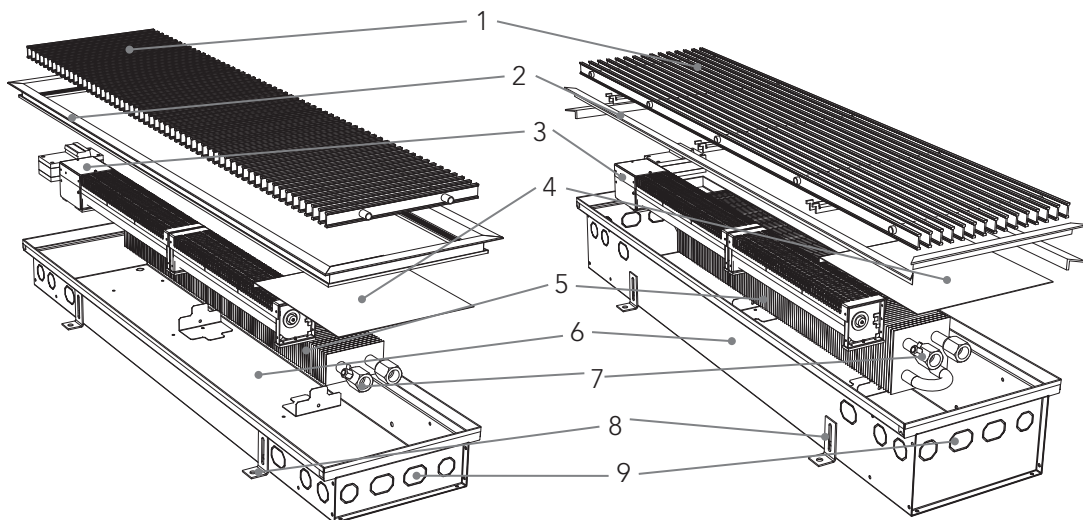

- Key**
- | | |
|-----------------------------------|------------------------------|
| 1 Roll-up grille or linear grille | 6 Convector trench |
| 2 Frame (O, U, L, Z) | 7 Air vent |
| 3 Fan | 8 Adjustable anchor brackets |
| 4 Cover plate | 9 Perforations |
| 5 Fins of heat exchanger | |

Due to the nature of their construction, linear grilles are only suitable for the 140 mm height.

Outputs

Intratherm F1T – Outputs

- Convector lengths are available accurate to within 1 cm
- Lengths over 5 m available upon request

Width (mm)		260						290						340					
↕ Height (mm)	↕ Revolution speed	90			140			90			140			90			140		
		1	2	3	1	2	3	1	2	3	1	2	3	1	2	3	1	2	3
↔ Length (mm)	↔ Heat output [W] at 75/65/20 °C																		
		800		468	617	781	685	902	1142	610	803	1016	898	1182	1496	714	940	1190	1016
900		552	727	920	808	1063	1346	718	946	1197	1058	1393	1763	841	1108	1402	1197	1576	1996
1000		636	837	1060	930	1225	1550	827	1089	1379	1218	1604	2030	969	1275	1614	1379	1815	2298
1100		719	947	1199	1052	1386	1754	936	1233	1560	1379	1815	2298	1096	1443	1827	1560	2054	2600
1200		845	1112	1408	1236	1627	2060	1045	1376	1742	1619	2131	2698	1288	1695	2146	1832	2413	3054
1250		845	1112	1408	1236	1627	2060	1045	1376	1742	1619	2131	2698	1288	1695	2146	1832	2413	3054
1300		887	1167	1478	1297	1708	2162	1154	1519	1923	1699	2237	2832	1351	1779	2252	1923	2532	3205
1400		929	1223	1548	1358	1789	2264	1208	1591	2014	1779	2343	2966	1415	1863	2358	2014	2651	3356
1500		1054	1388	1757	1542	2030	2570	1372	1806	2286	2020	2659	3366	1606	2114	2677	2286	3010	3810
1600		1054	1388	1757	1542	2030	2570	1372	1806	2286	2020	2659	3366	1606	2114	2677	2286	3010	3810
1700		1221	1608	2035	1787	2352	2978	1589	2093	2649	2340	3082	3901	1861	2450	3101	2649	3487	4414
1750		1221	1608	2035	1787	2352	2978	1589	2093	2649	2340	3082	3901	1861	2450	3101	2649	3487	4414
1800		1305	1718	2175	1909	2514	3182	1698	2236	2830	2501	3293	4168	1988	2618	3314	2830	3726	4717
1900		1305	1718	2175	1909	2514	3182	1698	2236	2830	2501	3293	4168	1988	2618	3314	2830	3726	4717
2000		1472	1938	2454	2154	2836	3590	1916	2522	3193	2821	3715	4702	2243	2954	3739	3193	4204	5321
2100		1556	2049	2593	2276	2997	3794	2025	2666	3374	2982	3926	4969	2371	3121	3951	3374	4443	5624
2200		1640	2159	2733	2399	3158	3998	2134	2809	3556	3142	4137	5236	2498	3289	4164	3556	4682	5926
2250		1640	2159	2733	2399	3158	3998	2134	2809	3556	3142	4137	5236	2498	3289	4164	3556	4682	5926
2300		1640	2159	2733	2399	3158	3998	2134	2809	3556	3142	4137	5236	2498	3289	4164	3556	4682	5926
2400		1723	2269	2872	2521	3319	4202	2242	2952	3737	3302	4348	5504	2626	3457	4376	3737	4921	6229
2500		1890	2489	3151	2766	3642	4610	2460	3239	4100	3623	4770	6038	2880	3793	4801	4100	5398	6833
2600		1974	2599	3290	2888	3803	4813	2569	3382	4282	3783	4981	6305	3008	3960	5013	4281	5637	7136
2700		2058	2709	3430	3010	3964	5017	2678	3526	4463	3943	5192	6572	3135	4128	5226	4463	5876	7438
2750		2058	2709	3430	3010	3964	5017	2678	3526	4463	3943	5192	6572	3135	4128	5226	4463	5876	7438
2800		2058	2709	3430	3010	3964	5017	2678	3526	4463	3943	5192	6572	3135	4128	5226	4463	5876	7438
2900	Galvanized*	2141	2820	3569	3133	4125	5221	2787	3669	4644	4104	5403	6840	3263	4296	5438	4644	6115	7740
3000		2309	3040	3848	3378	4447	5629	3004	3956	5007	4424	5825	7374	3518	4632	5863	5007	6593	8345
3100		2309	3040	3848	3378	4447	5629	3004	3956	5007	4424	5825	7374	3518	4632	5863	5007	6593	8345
3200		2392	3150	3987	3500	4608	5833	3113	4099	5189	4585	6036	7641	3645	4800	6075	5188	6831	8647
3250		2476	3260	4127	3622	4769	6037	3222	4242	5370	4745	6247	7908	3773	4967	6288	5370	7070	8950
3300		2476	3260	4127	3622	4769	6037	3222	4242	5370	4745	6247	7908	3773	4967	6288	5370	7070	8950
3400		2643	3480	4406	3867	5092	6445	3440	4529	5733	5066	6670	8443	4028	5303	6713	5733	7548	9554
3500		2643	3480	4406	3867	5092	6445	3440	4529	5733	5066	6670	8443	4028	5303	6713	5733	7548	9554
3600		2811	3701	4684	4112	5414	6853	3657	4816	6096	5386	7092	8977	4283	5639	7138	6096	8026	10159
3700		2811	3701	4684	4112	5414	6853	3657	4816	6096	5386	7092	8977	4283	5639	7138	6096	8026	10159
3750		2811	3701	4684	4112	5414	6853	3657	4816	6096	5386	7092	8977	4283	5639	7138	6096	8026	10159
3800		2811	3701	4684	4112	5414	6853	3657	4816	6096	5386	7092	8977	4283	5639	7138	6096	8026	10159
3900		2811	3701	4684	4112	5414	6853	3657	4816	6096	5386	7092	8977	4283	5639	7138	6096	8026	10159
4000		2944	3877	4907	4308	5672	7179	3832	5045	6386	5643	7429	9404	4486	5907	7477	6386	8408	10643
4100		3028	3987	5047	4430	5833	7383	3940	5188	6567	5803	7640	9671	4614	6075	7690	6567	8647	10945
4200		3112	4097	5186	4552	5994	7587	4049	5332	6749	5963	7852	9939	4741	6243	7902	6749	8886	11248
4250		3112	4097	5186	4552	5994	7587	4049	5332	6749	5963	7852	9939	4741	6243	7902	6749	8886	11248
4300		3112	4097	5186	4552	5994	7587	4049	5332	6749	5963	7852	9939	4741	6243	7902	6749	8886	11248
4400		3279	4317	5465	4797	6316	7995	4267	5618	7112	6284	8274	10473	4996	6578	8327	7111	9363	11852
4500		3279	4317	5465	4797	6316	7995	4267	5618	7112	6284	8274	10473	4996	6578	8327	7111	9363	11852
4600	3279	4317	5465	4797	6316	7995	4267	5618	7112	6284	8274	10473	4996	6578	8327	7111	9363	11852	
4700	3363	4428	5605	4920	6477	8199	4376	5762	7293	6444	8485	10740	5124	6746	8540	7293	9602	12155	
4750	3530	4648	5883	5164	6800	8607	4594	6048	7656	6765	8907	11275	5379	7082	8964	7656	10080	12759	
4800	3530	4648	5883	5164	6800	8607	4594	6048	7656	6765	8907	11275	5379	7082	8964	7656	10080	12759	
4900	3614	4758	6023	5287	6961	8811	4702	6192	7837	6925	9118	11542	5506	7250	9177	7837	10319	13062	
5000	3781	4978	6302	5531	7283	9219	4920	6478	8200	7246	9540	12076	5761	7585	9602	8200	10797	13667	

* Floor trench coated in RAL 9005 Black (epoxy polyester coating), made from galvanized steel on both sides

326 INTRATHERM F1T

Outputs for versions with stainless steel and wooden grilles/weights and water capacity/dimensions

Intratherm F1T – Outputs

The maximum length of the convector is unlimited. Convectors over 3500 mm in length can be created by fitting together multiple modules and feature at least two heat exchangers.

Heat output, measured in accordance with EN 442; coefficients for converting heat output – see page 352.

All heat outputs shown relate to the aluminium version. In the case of stainless steel and wooden grilles, the heat output value needs to be multiplied by a correction factor (see adjacent table).

Grille	Free cross-section (%)	Correction factor (-)
Aluminium	0,71	1,00
Wood	0,58	0,95
Stainless steel	0,58	0,95

Intratherm F1T – electric output

Convector length (mm)	800 - 1900	2000 - 3500	3600 - 3900	4000 - 7000
Number of fans	1	2	3	4
Electric output (VA)	10	20	30	40

Intratherm F1T – Weight and water capacity

Width (mm)	260		290		340	
	90	140	90	140	90	140
Weight (kg/m)	7,8	9,7	8,7	11,2	10,1	13,9
Water capacity (l/m)	0,3	0,7	0,4	1,0	0,7	1,4

Intratherm F1T – Dimensions

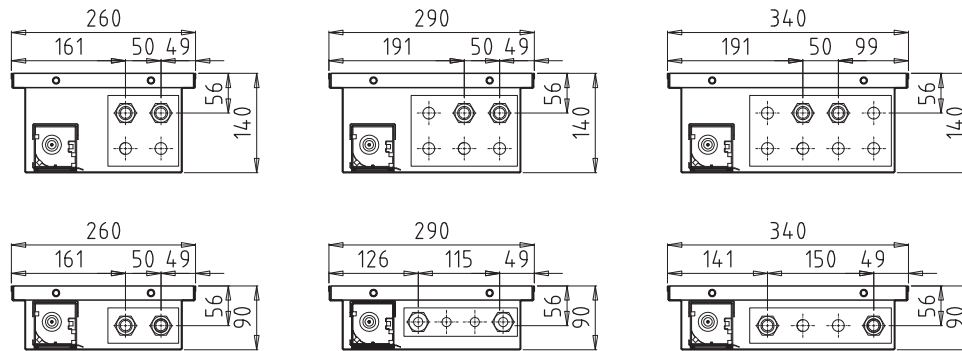

Connection from the left

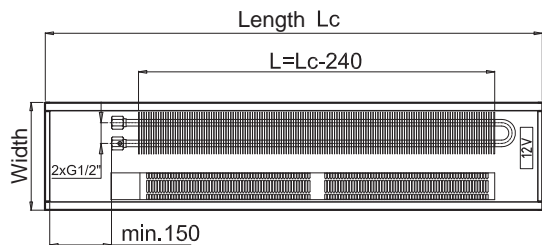

Connection from the right

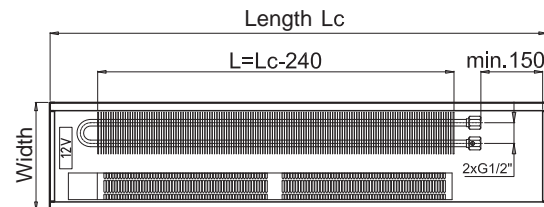

The convector connection can be selected at the installation site itself by turning the heat exchanger.

Sound level/item numbers

Intratherm F1T – sound level L_{pA}													
Convector length	(mm)	800 - 900	1000 - 1400	1500 - 1900	2000 - 2250	2300 - 2700	2750 - 3500	3550 - 3900	3950 - 4700	4750 - 4900	4950 - 5150	5200 - 5350	5400 - 7000
Number of impellers	(-)	1	2	3	4	5	6	7	8	9	10	11	12
Revolution speed 3	dB(A)	27,1	28,2	29	29,7	30,3	30,9	31,3	31,8	32,2	32,5	32,8	33,1
Revolution speed 2	dB(A)	25,5	26,6	27,4	28,1	28,7	29,3	29,7	30,2	30,5	30,9	31,2	31,5
Revolution speed 1	dB(A)	17	18,1	18,9	19,6	20,2	20,8	21,2	21,7	22	22,4	22,7	23

Sound level L_{pA} in dB(A) at a distance of 1 m from the convector

The convector connection can be selected at the installation site itself by turning the heat exchanger.

For details regarding control and the recommended circuit diagrams, see page 340.

For a choice of accessories, see price list on page 267.

Correction factor for conversion of heat output

For a table with correction factors for converting the heat output, see page 352.

Pressure losses

For diagrams of pressure losses of the heat exchanger for convectors, see page 353.

INTRATHERM F1P.

An even more efficient variant with 12V tangential fan (EC motor) for heating



The Intratherm F1P Trench convectors succeed the original series of FPT convectors with fans. They offer a cost-effective variant with increased heat output, reduced noise level and minimal operating costs. The length of the fan has been chosen in such a way that the largest possible area of the heat exchanger is supplied with air. The heat output of the convector can be controlled either by hot water or by the air from the fan. All fans are fitted with energy-saving 12 V EC motors.

- Standard height 90 mm
- 2 standard widths (180, 260 mm)
- Lengths from 800 mm

Benefits of the new technical solution

- Effective use of the space inside the trench
- Optimised length of fan relative to the heat exchanger
- Increase in heat output
- Reduction of the price of the convector, in relation to heat output (see F1T)
- Considerable reduction in electrical power used by the convector
- Considerable reduction in operating costs
- Reduction of the noise level

Technical specification:

- Heat output, measured in accordance with EN 442
- Test overpressure 13 bar
- Max. operating overpressure 10 bar
- Maximum operating pressure 110 °C



Guarantee statements are available to download at www.vogelundnoot/download

Intratherm F1P – even more efficient variant with 12V tangential fan (EC motor) for heating

Intratherm F1P standard delivery includes:

- A trench made of steel, galvanized on both sides and coated in RAL 9005 Black
- Front and side components of the trench with perforations for the water connection and feeding the cable, enabling the heat exchanger and fan to be connected from the right and the left
- Fully corrosion-proof copper/aluminium heat exchanger with minimal water content, with air vent, coated in RAL 9005 Black
- Tangential fan with 12 V EC motor
- EC fan drive with minimal electrical consumption
- Cover plate for the water connection
- All trench components coated in RAL 9005 Black as standard
- Wooden cover plate, which protects the trench, the heat exchanger and the fan during transport and installation
- Accessories supplied as standard: setting screws M8 x 30 for setting the position of the trench, floor screed anchor for fixing the trench into the concrete, rubber bushings for the perforations, flexible stainless steel connecting hoses with seal, anchor brackets for setting the trench height
- Impact-noise insulation between the grille and the trench

Extras:

- Trench made from brushed stainless steel sheeting
- Accessories: thermostatic valve, lockshield valve, thermostatic head with remote controller, adjusting drive, room thermostat with speed setting switch
- Insulation of the trench floor, three-sided insulation of the trench
- Coatings for the trench, heat exchanger and other components in a different RAL colour



Construction of the Intratherm F1P Trench convector

F1P 180 x 1250 x 90 mm with an aluminium roll-up grille with L-frame

F1P 260 x 1250 x 140 mm with an aluminium linear grille and Z-frame

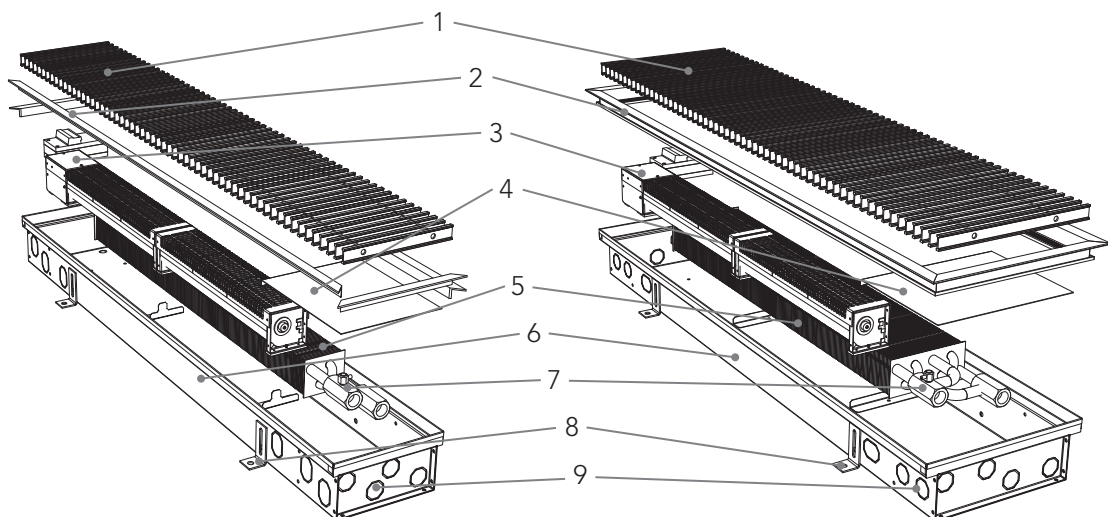

Key

- | | |
|------------------------------|------------------------------|
| 1 Roll-up grille | 6 Convector trench |
| 2 Frame (O, U, L, Z) | 7 Air vent |
| 3 Fan | 8 Adjustable anchor brackets |
| 4 Cover plate | 9 Perforations |
| 5 Fins of the heat exchanger | |

Due to the nature of the construction, the 90 mm height only allows for the use of roll-up grilles.

Intratherm F1P – Outputs

- Convector lengths are available accurate to within 1 cm
- Lengths over 5 m available upon request

Width (mm)		180			260		
↕	Height (mm)	90			90		
	Revolution speed	1	2	3	1	2	3
↔	Length (mm)	Heat output [W] at 75/65/20 °C					
	800	Galvanized*	395	520	659	579	762
900	395		520	659	579	762	965
1000	625		823	1041	915	1205	1525
1100	625		823	1041	915	1205	1525
1200	625		823	1041	915	1205	1525
1250	855		1125	1424	1252	1648	2086
1300	855		1125	1424	1252	1648	2086
1400	855		1125	1424	1252	1648	2086
1500	1084		1428	1807	1588	2091	2647
1600	1084		1428	1807	1588	2091	2647
1700	1084		1428	1807	1588	2091	2647
1750	1314		1730	2190	1925	2534	3208
1800	1314		1730	2190	1925	2534	3208
1900	1314		1730	2190	1925	2534	3208
2000	1544		2033	2573	2261	2977	3769
2100	1544		2033	2573	2261	2977	3769
2200	1544		2033	2573	2261	2977	3769
2250	1774		2335	2956	2598	3420	4329
2300	1774		2335	2956	2598	3420	4329
2400	1774		2335	2956	2598	3420	4329
2500	2003	2638	3339	2934	3863	4890	
2600	2003	2638	3339	2934	3863	4890	
2700	2003	2638	3339	2934	3863	4890	
2750	2233	2940	3722	3271	4306	5451	
2800	2233	2940	3722	3271	4306	5451	
2900	2233	2940	3722	3271	4306	5451	

Width (mm)		180			260		
↕	Height (mm)	90			90		
	Revolution speed	1	2	3	1	2	3
↔	Length (mm)	Heat output [W] at 75/65/20 °C					
	3000	Galvanized*	2463	3243	4105	3607	4749
3100	2463		3243	4105	3607	4749	6012
3200	2463		3243	4105	3607	4749	6012
3250	2693		3545	4488	3944	5192	6573
3300	2693		3545	4488	3944	5192	6573
3400	2693		3545	4488	3944	5192	6573
3500	2693		3545	4488	3944	5192	6573
3600	2693		3545	4488	3944	5192	6573
3700	2858		3763	4763	4186	5511	6976
3750	2858		3763	4763	4186	5511	6976
3800	2858		3763	4763	4186	5511	6976
3900	2858		3763	4763	4186	5511	6976
4000	3088		4066	5146	4522	5954	7537
4100	3088		4066	5146	4522	5954	7537
4200	3088		4066	5146	4522	5954	7537
4250	3317		4368	5529	4859	6397	8098
4300	3317		4368	5529	4859	6397	8098
4400	3317		4368	5529	4859	6397	8098
4500	3547		4671	5912	5195	6840	8659
4600	3547		4671	5912	5195	6840	8659
4700	3547	4671	5912	5195	6840	8659	
4750	3777	4973	6295	5532	7284	9220	
4800	3777	4973	6295	5532	7284	9220	
4900	3777	4973	6295	5532	7284	9220	
5000	4007	5275	6678	5868	7727	9780	

* Floor trench coated in RAL 9005 Black (epoxy polyester coating), made from steel, galvanized on both sides.

Intratherm F1P - Outputs

The maximum length of the convector is unlimited. Convectors over 3500 mm in length can be created by fitting together multiple modules and feature at least two heat exchangers.

Heat output, measured in accordance with EN 442; coefficients for converting heat output – see page 352.

All heat outputs shown relate to the aluminium version. In the case of stainless steel and wooden grilles, the heat output value needs to be multiplied by a correction factor (see adjacent table).

Grille	Free cross-section (%)	Correction factor (-)
Aluminium	0,71	1,00
Wood	0,58	0,95
Stainless steel	0,58	0,95

Outputs/electrical power/weights and water capacity/dimensions/sound level/item numbers

Intratherm F1P – electrical power					Intratherm F1P – Weight and water capacity		
Convector length (mm)	800 - 1900	2000 - 3500	3600 - 3900	4000 - 7000	Width (mm)	180	260
Number of fans	1	2	3	4	Height (mm)	90	90
Electrical power	10	20	30	40	Weight kg/m	7,2	9,0
					Water capacity (l/m)	0,4	0,7

Intratherm F1P – Abmessungen

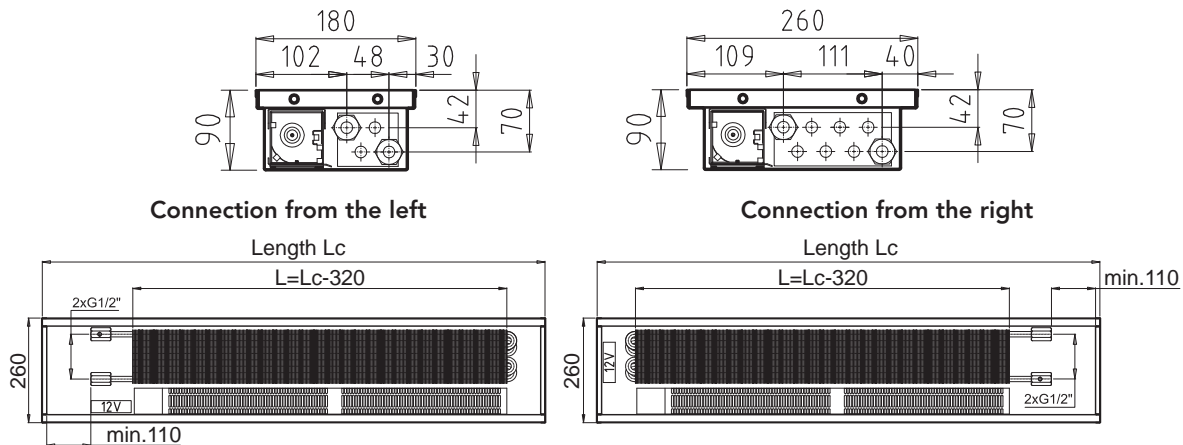

The convector connection can be selected at the installation site itself by turning the heat exchanger.

Intratherm F1T – sound level L_{pA}													
Convactor length	(mm)	800 - 900	1000 - 1400	1500 - 1900	2000 - 2250	2300 - 2700	2750 - 3500	3550 - 3900	3950 - 4700	4750 - 4900	4950 - 5150	5200 - 5350	5400 - 7000
Number of impellers	(-)	1	2	3	4	5	6	7	8	9	10	11	12
Revolution speed 3	dB(A)	27,1	28,2	29	29,7	30,3	30,9	31,3	31,8	32,2	32,5	32,8	33,1
Revolution speed 2	dB(A)	25,5	26,6	27,4	28,1	28,7	29,3	29,7	30,2	30,5	30,9	31,2	31,5
Revolution speed 1	dB(A)	17	18,1	18,9	19,6	20,2	20,8	21,2	21,7	22	22,4	22,7	23

Sound level L_{pA} in dB(A) at a distance of 1 m from the convector

The convector connection can be selected at the installation site itself by turning the heat exchanger.

For details regarding control and recommended circuit diagrams, see page 340.

For a choice of accessories, see price list on page 267.

Correction factor for conversion of heat output

For a table with correction factors for converting the heat output, see page 352.

Pressure losses

For diagrams of pressure losses of the heat exchanger for convectors, see page 353.

INDIVIDUAL HEAT EXCHANGERS.

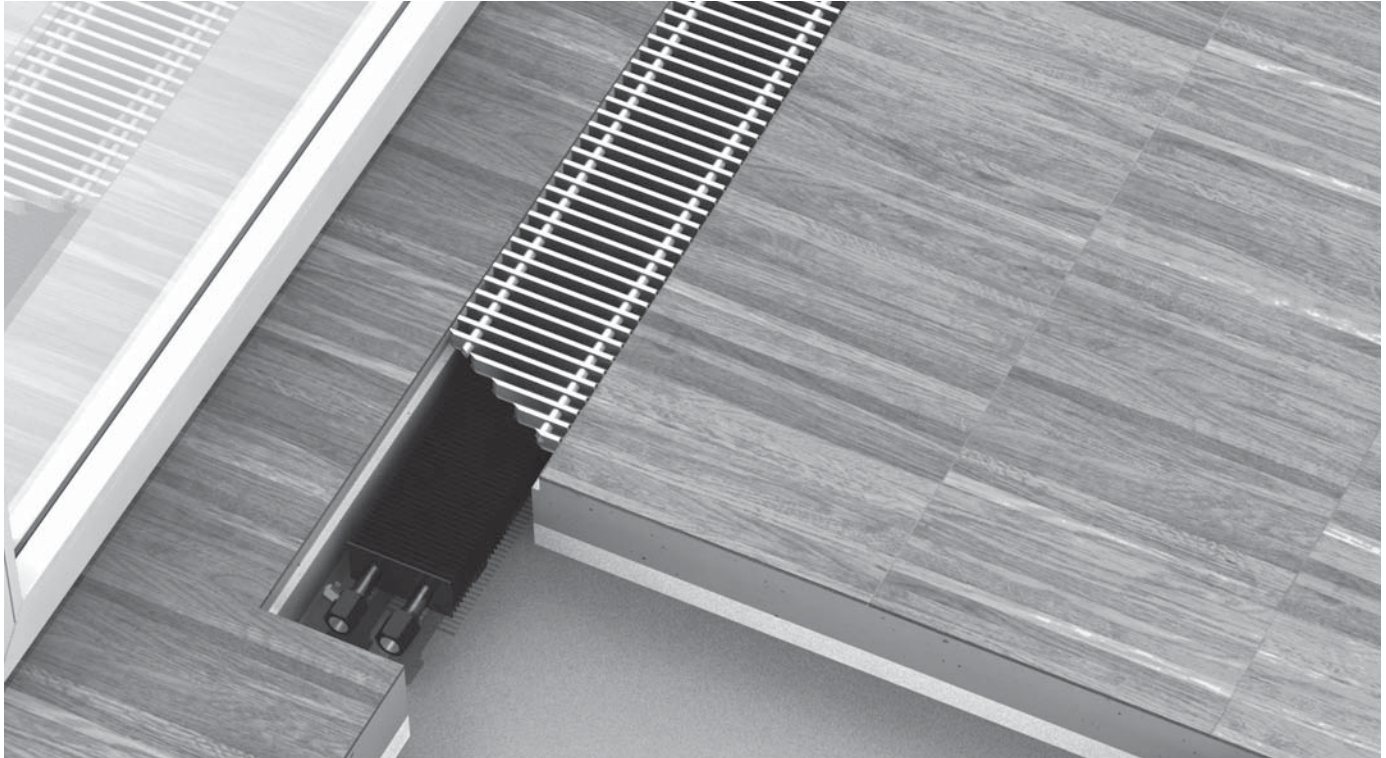

Heat exchangers

In view of a variety of individual requirements expressed by our customers, we have expanded our product range to include individual heat exchangers that are installed in the Intratherm Trench convectors as standard. The individually installed heat exchangers are suitable for use in reconstructions of cellars, loft spaces or attics, as well as for installation in window sills or for installation in channels or gutters. Consoles for the installation of heat exchangers in floors or in the wall are also supplied as accessories with the heat exchangers.

Models and designs of heat exchangers

The standard range of heat exchangers comprises 125 combinations of dimensions, which equates to 5 models of heat exchanger in 25 lengths ranging from 675 mm to 3375 mm. The LVF 09 and 19 and LVR 10, 15 and 20 heat exchangers are the basic models. The heat exchangers in the LVF series, with an overall height of 50 mm and a width of 100 or 200 mm are suitable for use wherever it is necessary to minimise the height of the construction. The LVR series of heat exchangers, with a uniform height of 100 mm and available in widths of 100, 150 and 200 mm, are suitable for use in cases where higher heat output is required. All heat exchangers come with copper pipes and aluminium plate-fins. They can be supplied with a coating in RAL 9005 Black upon request. Every heat exchanger features an air vent and two connections with a G 1/2" female screw thread.

Technical specification:

- Heat output, measured in accordance with EN 442
- Test overpressure 13 bar
- Max. operating overpressure 10 bar
- Maximum operating temperature 110 °C
- Installation of the heat exchanger to an enclosed hot water system

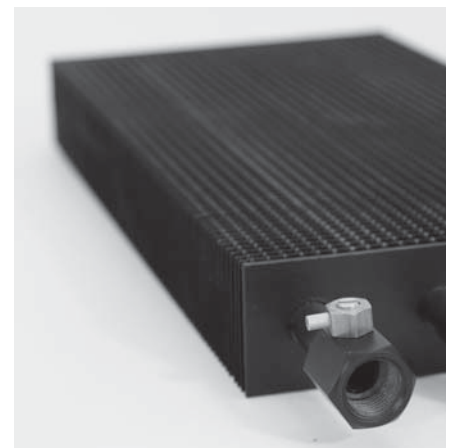

Outputs

Outputs						
Length of heat exchanger L ₁ (mm)	Finned length of heat exchanger (mm)	LVF-09	LVF-19	LVR-10	LVR-15	LVR-20
		50 x 100 mm	50 x 200 mm	100 x 100 mm	100 x 150 mm	100 x 200 mm
		Heat output [W] at 75/65/20 °C				
675	560	327	732	505	739	963
775	660	368	824	569	831	1083
875	760	408	915	632	923	1203
975	860	449	1007	695	1016	1324
1075	960	490	1098	758	1108	1444
1175	1060	531	1190	821	1200	1564
1275	1160	572	1281	884	1293	1685
1375	1260	613	1373	948	1385	1805
1475	1360	653	1464	1011	1477	1925
1575	1460	694	1556	1074	1570	2046
1675	1560	735	1647	1137	1662	2166
1775	1660	776	1739	1200	1754	2286
1875	1760	817	1830	1263	1847	2407
1975	1860	858	1922	1327	1939	2527
2075	1960	898	2013	1390	2031	2647
2175	2060	939	2105	1453	2124	2768
2275	2160	980	2196	1516	2216	2888
2375	2260	1021	2288	1579	2308	3008
2475	2360	1062	2379	1642	2401	3129
2575	2460	1103	2471	1706	2493	3249
2775	2660	1184	2654	1832	2678	3490
2875	2760	1225	2745	1895	2770	3610
2975	2860	1266	2837	1958	2862	3730
3175	3060	1348	3020	2085	3047	3971
3375	3260	1429	3203	2211	3232	4212

The height of the casing of LVF-09 and LVF-19 measures 90 mm and the height of the casing of LVR-10, LVR-15 and LVR-20 measures 140 mm. The underside of the heat exchanger sits 100 mm above the floor. The outputs shown relate to 100% free cross-section.

We reserve the right to amend typing errors and make technical changes. Valid from 1 February 2014.

334 INTRATHERM Individual heat exchangers

Weight and water capacity/dimensions/item numbers

Weight and water capacity					
Heat exchanger type	LVF-09	LVF-19	LVR-10	LVR-15	LVR-20
Weight (kg/m)	1,4	2,6	2,4	3,5	4,6
Water capacity (l/m)	0,3	0,7	0,7	1,0	1,4

Heat exchanger dimensions

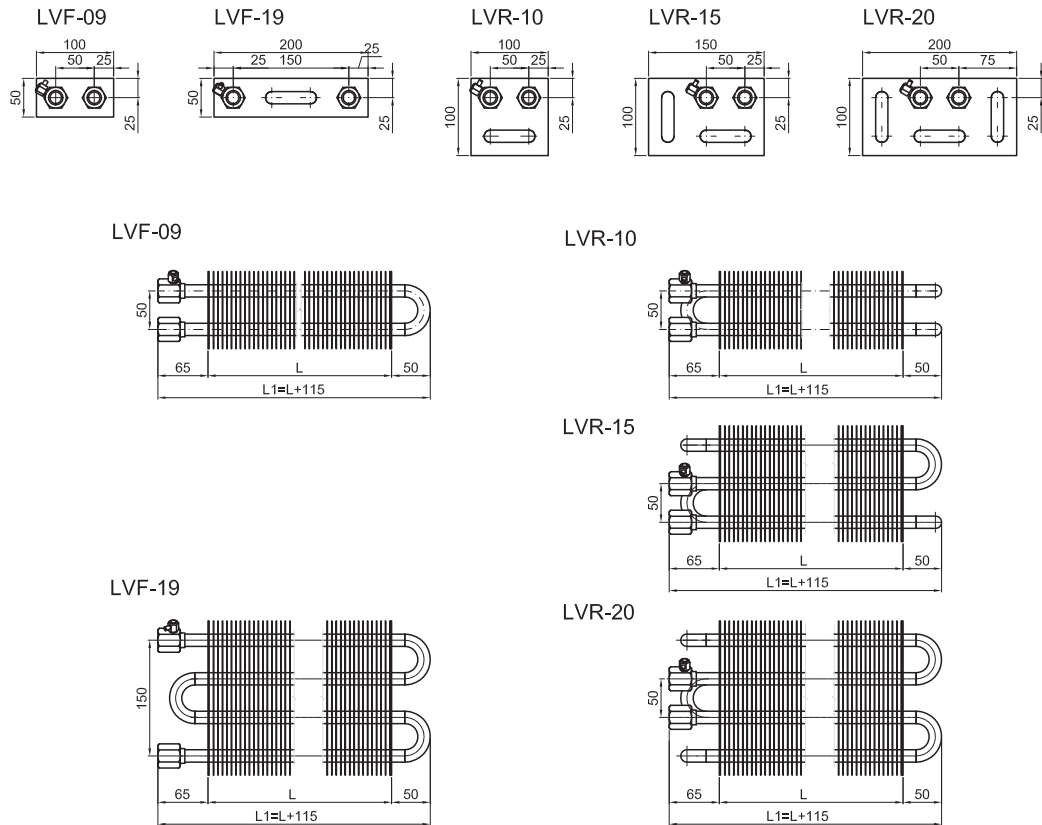

The convector connection can be selected at the installation site itself by turning the heat exchanger.

For details regarding control and recommended circuit diagrams, see page 340.

For a choice of accessories, see price list on page 267.

Correction factor for conversion of heat output

For a table with correction factors for converting the heat output, see page 352.

Pressure losses

For diagrams of pressure losses of the heat exchanger for convectors, see page 353.

Installation of heat exchangers

Floor bracket

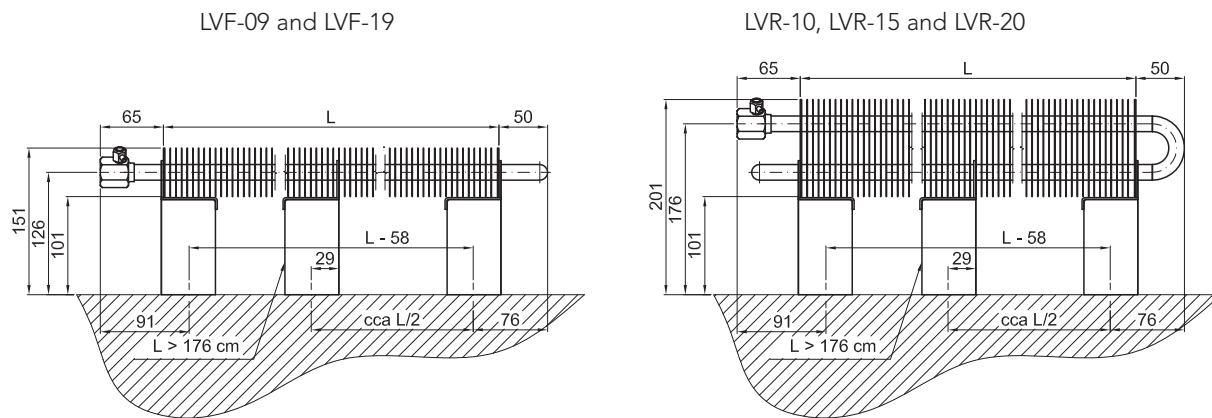

Finned lengths >1760 mm (3 fasteners)

Installation of the individual heat exchangers

- The surrounding material must be able to withstand the local temperature
- The heat exchangers must be installed onto brackets on the floor or on the wall by the installer
- In order to ensure problem-free ventilation, the heat exchanger must be installed in a horizontal position

- In order to guarantee maximum heat output, the free flow of air into and out of the heat exchanger must be ensured; obstructions to the inlet and outlet reduce heat output

Note

The heat output of heat exchangers built into floor channels is reduced by around 30% compared against the values shown in the output table for a 60% free cross-section of the cover grille.

Wall bracket

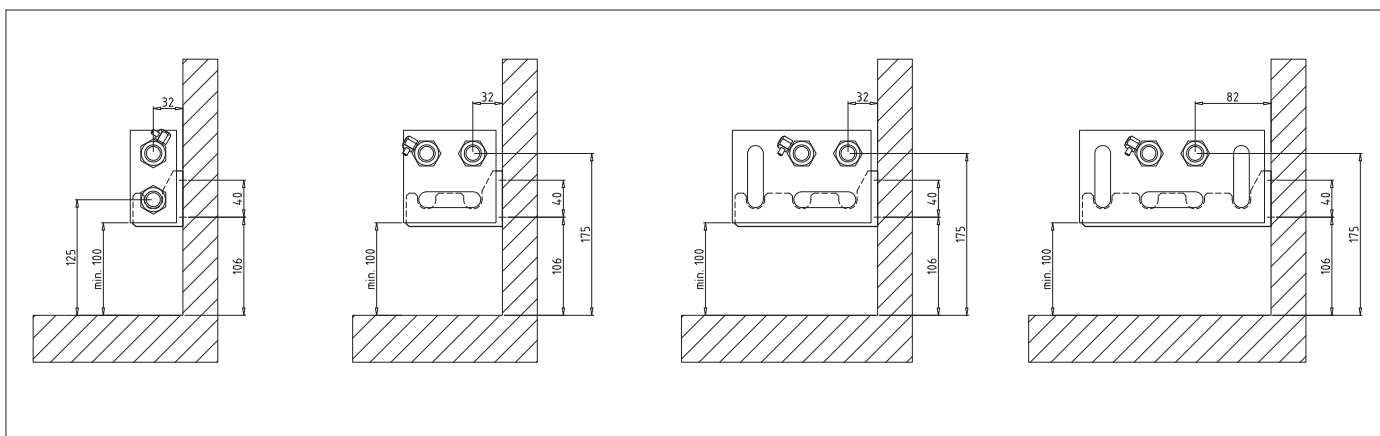

COVER GRILLES FOR FLOOR CONVECTORS.

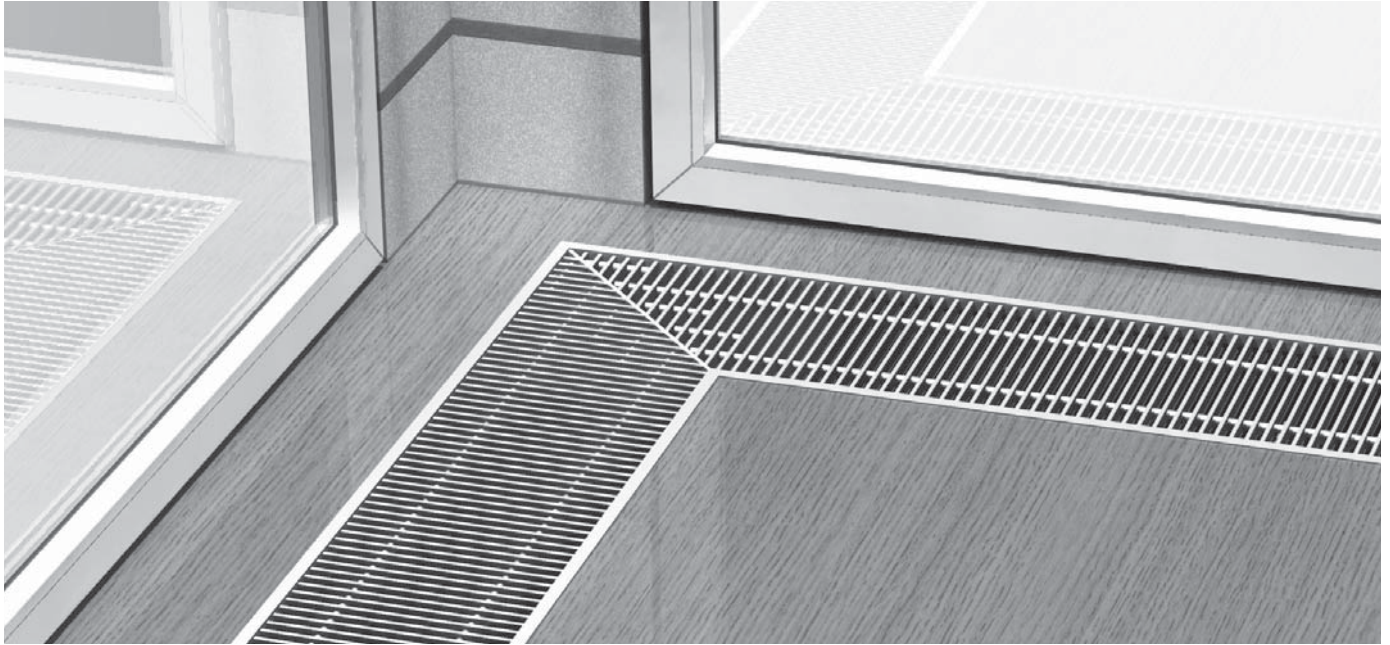

The cover grilles are practically the only visible part of the Trench convectors and for this reason a great deal of attention is paid to the material and the finish of the grilles. Apart from this design aspect, the cover grille also performs technical functions. It ensures even load-bearing, which is spread over the edges of the trench onto the base, while at the same time the shape of the bars determines the air flow. The air flow of the cover grille is characterised by the parameter of the free cross-section of the grille. The cover grilles are supplied separately or together with the convectors. The product range is not restricted to standard dimensions but also provides for special solutions according to customer requirements.

Technical designs

VOGEL&NOOT offers two basic technical variants – roll-up grille or linear grille. In the case of the roll-up grille, the bars and a series of spacer rings are all fixed onto a spring, which enables the grille to roll out. The linear grille cannot be used with trenches greater than 90 mm in height for reasons relating to construction.

Materials

The cover grilles are manufactured from aluminium, stainless steel or wooden bars. All grilles come in the standard height of 20 mm. The grilles made from anodised aluminium are available in the colours natural, dark bronze, light bronze or black as standard. The grilles with wooden bars are available in beech and oak. Both designs can be supplied as untreated, polished or varnished. Dimensional stability cannot be guaranteed for untreated wooden grilles, as they may expand depending on moisture levels.

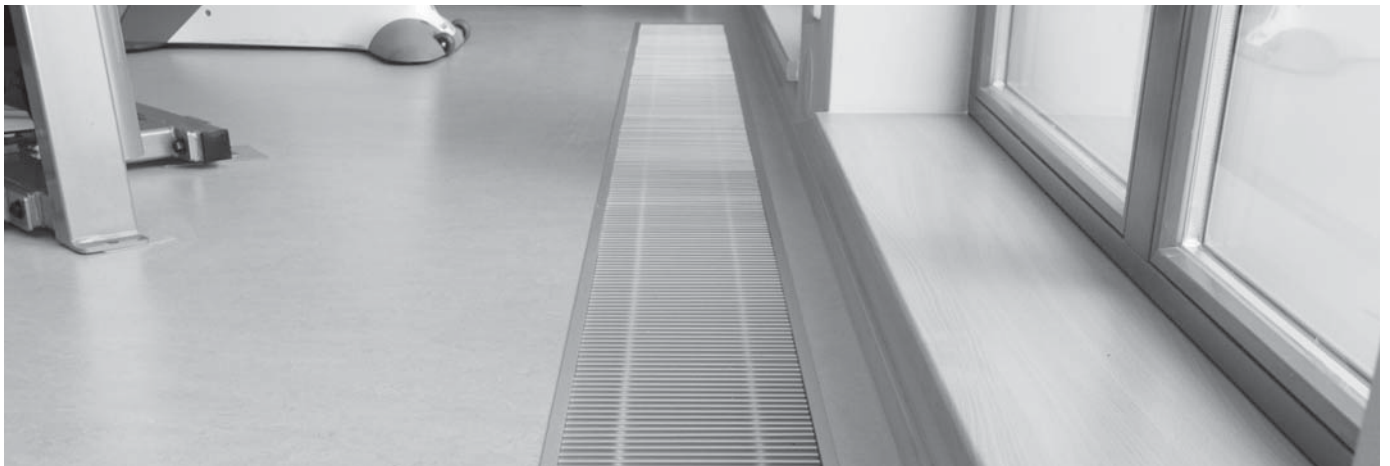

Overview of cover grilles

Aluminium roll-up grille

Coloured finish (anodised):

- natural
- light bronze
- dark bronze
- black

Free cross-section: 71%
PMO, PMU, PML, PMZ

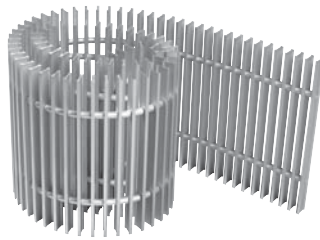

Roll-up grille dimensions

Aluminium roll-up grille and linear grille

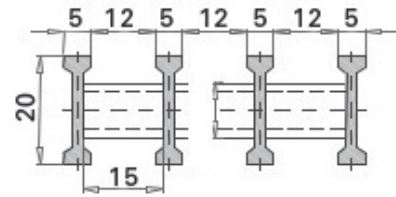

Aluminium linear grille

Coloured finish (anodised):

- natural
- light bronze
- dark bronze
- black

Free cross-section: 71%

Not suitable for use with convectors of 90 mm in height.

PMO, PMU, PML, PMZ

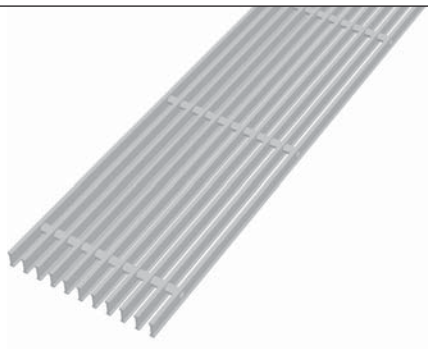

Wooden roll-up grille

Grille with oak or beech bars.

The grille is treated with a protective agent – colourless oil – as standard.

Free cross-section: 58%
PMO, PMU, PML, PMZ

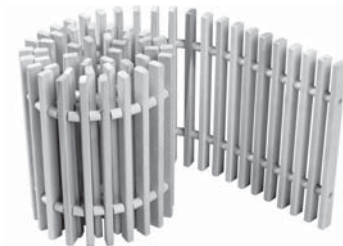

Wooden grille (roll-up grille only)

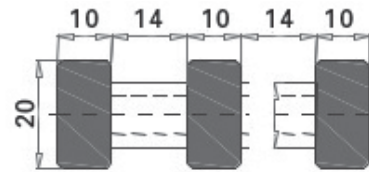

Stainless steel roll-up grille (polished or glass bead-blasted)

Material: 1.4301

Free cross-section: 58%
PMO, PMU, PML, PMZ

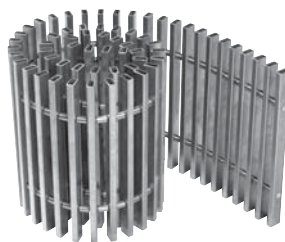

Stainless steel roll-up and linear grille

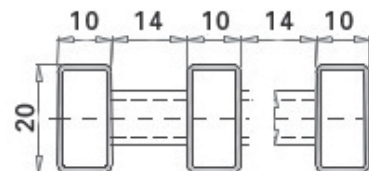

Stainless steel linear grille (polished or glass bead-blasted)

Material: 1.4301

Free cross section: 58%

Not suitable for use with convectors of 90 mm in height.

PMO, PMU, PML, PMZ



Bar dimensions and bar spacings are the same for roll-up and linear grilles.

For the overview of colours, see the price list on page 336.

Anodised aluminium frames

The frames are used to cover the intersection between the convector trench and the completed floor. U frames and L-frames are available in the same colours as the aluminium grilles. Z-frames are only available as natural aluminium.

Frameless design

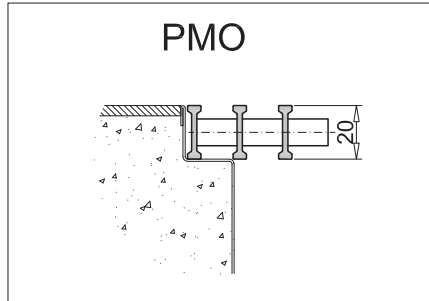

U-frame design

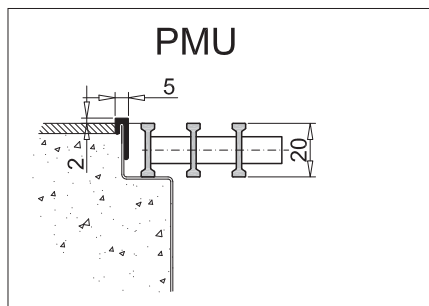

L-frame design

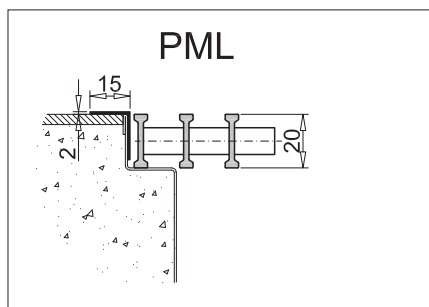

Z-frame design

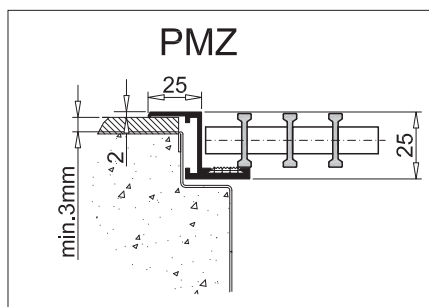

The Z-frame, L-frame and U-frame must all be ordered together with the grille. It is not possible to place a subsequent order for the frame for a grille that has already been delivered. If using the Z-frame, the trench is to be laid 3-5 mm below the level of the completed floor (see diagram). The Z-frame is delivered as a whole unit that is ready to install. We recommen-

ded that the frame is affixed to the floor with silicone sealant.

The L-frame consists of individual profiles that are prepared for mounting on the completed floor. The L frame is affixed on the inside with double-sided adhesive tape.

In the event that the floor trench is damaged or deformed as a result of improper installation, the manufacturer shall not accept any responsibility in relation to the installation of the frame.

Grille materials



- Natural beech
- Varnished beech
- Natural oak
- Varnished oak



- Natural aluminium
- Black aluminium
- Dark bronze aluminium
- Light bronze aluminium

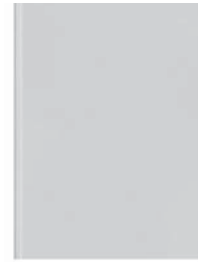

- Stainless steel

For the colour overview, see the price list on page 274

Supports for the linear grilles

To prevent warping of the linear grille, the accompanying load-bearing spacers must be used as supports. The load-bearing spacers are laid approximately 30 cm apart. For reasons relating to construction, rigid grilles cannot be used with convectors greater than 90 mm in height (FMK, F1T, F1P).

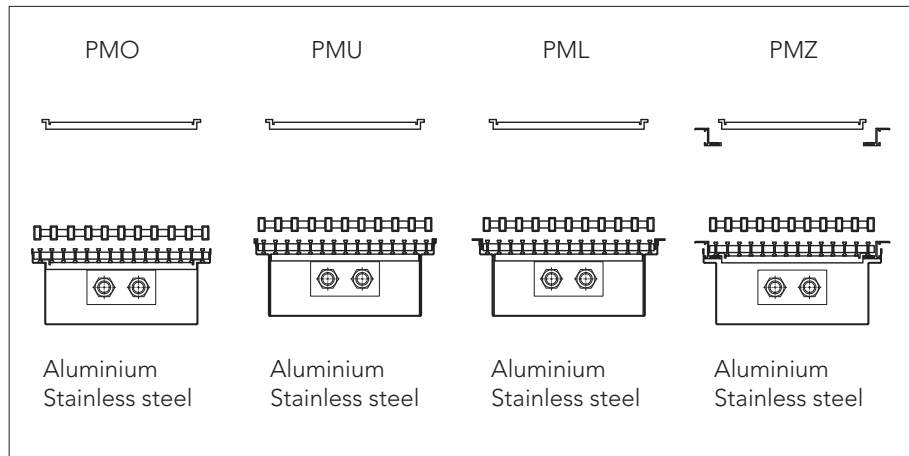
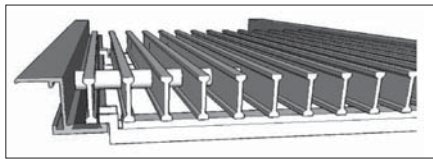

Grille – Weight																									
Width (mm)		180				240				260				290				340				420			
Type of grille		PMO	PMU	PML	PMZ	PMO	PMU	PML	PMZ	PMO	PMU	PML	PMZ	PMO	PMU	PML	PMZ	PMO	PMU	PML	PMZ	PMO	PMU	PML	PMZ
Weight (kg/m)	Aluminium	2,0	2,2	2,3	3,1	2,6	2,8	2,9	3,7	2,8	3,0	3,1	3,9	3,1	3,3	3,4	4,2	3,6	3,8	3,9	4,7	4,3	4,6	4,7	5,6
	Beech, oak	1,4	1,6	1,7	2,5	1,8	2,0	2,1	3,0	1,9	2,2	2,3	3,1	2,1	2,4	2,5	3,3	2,4	2,7	2,8	3,7	3,0	3,3	3,4	4,2
	Stainless steel	3,6	3,8	3,9	4,6	4,7	4,9	5,0	5,7	5,1	5,3	5,4	6,0	5,7	5,9	6,0	6,6	6,6	6,8	6,9	7,5	8,0	8,3	8,4	9,0

Controlling the heat output of the Intratherm convector

Note:

1) Installation and start-up is to be carried out by an authorised specialist company

2) During the installation, it must be ensured that the convector is in a voltage-free state

The heat output of the convector can

be controlled either by means of hot water or by air (only in the version with a fan). The quantity of hot water is adjusted by the thermostatic valve lift (thermostatic head with remote control setting or adjusting drive controlled by the room thermostat).

Control by means of air (F1T, F1P) is effected by the revolution speed. The revolution speed can be controlled either manually or automatically via a room thermostat.

Type of heat output control – a list of accessories to choose from

	Item no.	Description
1. Heat output control by hot water (FMK)		
1.1	AZAPTH01	Thermostatic head with remote control
1.2	AZAPPT01	Room thermostat
1.3	AZAPTP01, AZAPTP02	Thermal adjusting drive (01 – opened currentless, 02 – closed currentless)
2. Heat output control by air (F1T, F1P)		
2.1	AZAPSP01	Manual fan speed switch
2.2	AZAPPT02	Room thermostat with manual speed switch
2.3	AZAPER05	Room thermostat with automatic speed switch
2.4	AZAPER06	Room thermostat with automatic speed switch and 7-day programmable function

A PAT-controller must always be ordered with a convector for the purpose of controlling the fan revolution speed.

The model of controller (transformers) depends on the total number of connected fans and the type of controller

(on the surface, flush-mounted or in the trench).

PAT revolution speed controller for F1T and F1P

The control of heat output using fans is always effected by PAT transformers (3-step speed control). The size of the PAT transformers (02, 04, 06 or 08) depends on the number of motors. The number of motors per PAT transformer and the output can be found in the table below. The PAT transformers are available as surface or flush-mounted versions and as a version for fitting in the convector

trench.

AZAPATxxM controller

AZAPATxxM transformers can be ordered as either surface or flush-mounted versions, but not as a version for fitting in the convector trench. AZAPATxxM transformers can also be switched on/off in parallel. This offers the option to control multiple convectors simultane-

ously using a single speed switch. A single speed switch can control up to 200 AZAPATxxM transformers.

Version	Model	Electric output (VA)	Max. number of connectable motors		Cable recommended for connecting the convector	Thermostat	
			F1T (EC)	F1P (EC)		mechanical	electronic
Surface-mounted	AZAPAT02M01	90	8	8	CYKY-O 2x1,5	AZAPSP01 AZAPTP02	AZAPER05 AZAPER06
	AZAPAT04M01	160	15	15	CYKY-O 2x1,5		
	AZAPAT06M01	300	24	24	CYKY-O 2x2,5		
	AZAPAT08M01	300	30	31	CYKY-O 2x2,5		
Unterputz	AZAPAT02M02	90	8	8	CYKY-O 2x1,5		
	AZAPAT04M02	160	15	15	CYKY-O 2x1,5		
	AZAPAT06M02	300	24	24	CYKY-O 2x2,5		

PAT speed controller for F1T and F1P

AZAPATxxT controller

AZAPATxxT transformers are available as a surface- or flush-mounted version. The number of motors per PAT transformer and the output can be found in the table below.

Version	Model	Electric output (VA)	Max. number of connectable motors		Cable recommended for connecting the convector	Thermostat	
			F1T (EC)	F1P (EC)		F1T (EC), F1P (EC) F1T (EC), F1P (EC)	mechanical
Surface-mounted	AZAPAT02T01	90	8	8	CYKY-O 2x1,5	PSP-01, PTP-02	not possible
	AZAPAT04T01	160	15	15	CYKY-O 2x1,5		not possible
	AZAPAT06T01	300	24	24	CYKY-O 2x2,5		not possible
	AZAPAT08T01	300	30	30	CYKY-O 2x2,5		not possible
Flush-mounted	AZAPAT02T02	90	8	8	CYKY-O 2x1,5		not possible
	AZAPAT04T02	160	15	15	CYKY-O 2x1,5		not possible
	AZAPAT06T02	300	24	24	CYKY-O 2x2,5		not possible
in the convector trench	AZAPAT02T041	90	8	8	CYKY-J 5x1,5 (1 Leiter für die Erdung der Wanne)		not possible
	AZAPAT04T041	160	15	15			not possible
	AZAPAT06T041	300	24	24		not possible	

Note:

The AZAPATxxT speed controllers cannot be operated with the AZAPER05 and AZAPER06 thermostats. The AZAPATxxT speed controllers cannot be switched on/off in parallel.

The AZAPATxxT041 controller

- Transformer in the convector trench
- Protection mode IP 68
- Only in combination with the mechanical thermostats (AZAPSP01, AZAPPT02)
- A control module must be used with other thermostats (AZAPER05 and AZAPER06)

The AZAPATxxT041 controller is suitable for installation directly in the convector trench. The number of connectable motors is the same as in the case of the AZAPATxxT01 and AZAPATxxT02 controllers (see table above). A control component must always be used for operating the electric thermostats (AZAPER05 and AZAPER06).

Control components

Version	Number of controlled AZAPATxxT041 controllers	Dimensions (mm)
Surface-mounted		
AZAPATRM0101	1	165x120x63
AZAPATRM0201	2	230x185x90
AZAPATRM0301	3	325x255x120
AZAPATRMU4101	4	230x185x120
AZAPATRMU5101	5	
AZAPATRMU6101	6	
Flushmounted		
AZAPATRM0102	1	170x170x71
AZAPATRM0202	2	230x230x84
In the convector trench		
AZAPATRM0104	1	165x120x63

Dimensions of the AZAPATxxT041 controller

Cylindrical	Output	Max. power	Width	Height
	VA	A	mm	mm
AZAPAT02T041	90	7,5	Ø105	53
AZAPAT04T041	160	13,3	Ø125	53
AZAPAT06T041	300	24	Ø132	63

Intratherm – electrical circuits

Cable lines to the floor convectors F1T and F1P

The length of the cable between the convector and the speed controller (PAT) should not exceed 10 m. If this length is exceeded, a cable with a cross-section greater than the recommended one must be used, so that the potential drop in the cable does not exceed 1 V (recommended potential drop 0.5 V).

PAT transformers in the surface-mounted version are connected to the fused line (D6A) using a two core cable 2 x 1.5 mm². PAT transformers in the flush-mounted version are connected to the fused line using a three core cable 3 x 1.5 mm² (e.g. CYKY 3A x 1.5). To protect the switching circuit, a safety fuse is contained inside the controller.

A cable measuring 5 x 0.75 mm² is used to connect the PAT transformer with the speed controller or the speed controller with the room thermostat.

Dimensions of the PAT speed controller

Surface-mounted version

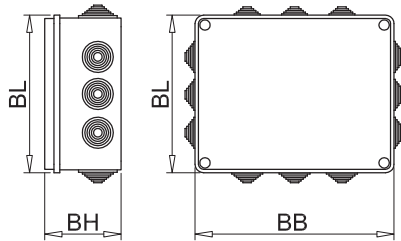

Flush-mounted version

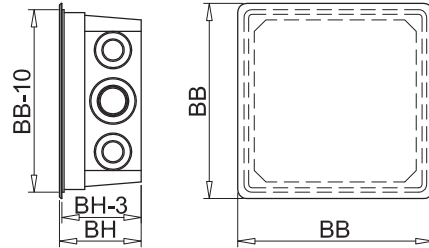

Model	Length BL (mm)	Width BB (mm)	Height BH (mm)	Weight (kg)
PAT-02-T, PAT-02-M-01	230	185	90	2,2
PAT-04-T, PAT-04-M-01	230	185	90	2,9
PAT-06-T, PAT-06-M-01	230	185	90	4,2
PAT-08-T, PAT-08-M-01	325	255	120	4,8

Model	Length BL (mm)	Width BB (mm)	Height BH (mm)	Weight (kg)
PAT-02-T, PAT-02-M-02	170	170	71	1,7
PAT-04-T, PAT-04-M-02	230	230	84	2,7
PAT-06-T, PAT-06-M-02	230	230	84	4,0
PAT-08-T, PAT-08-M-02	not possible			

Internal diagram of the PAT speed controller

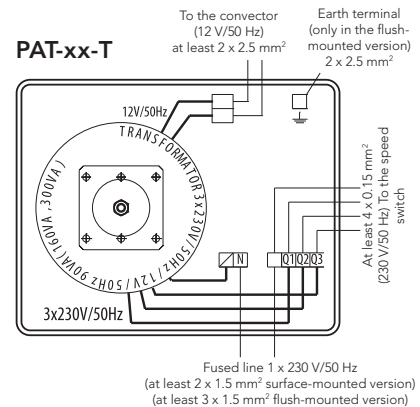
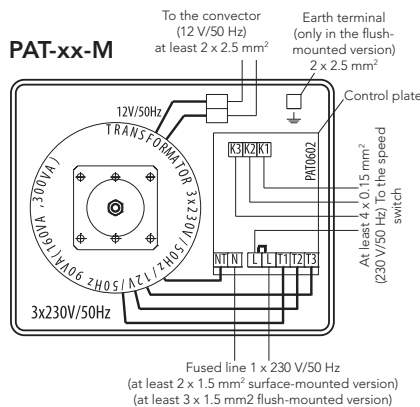

Intratherm – recommended circuit diagrams

Block diagram no. 1 – Intratherm FMK, controlled with adjusting drive – PTP-01 (currentless open)

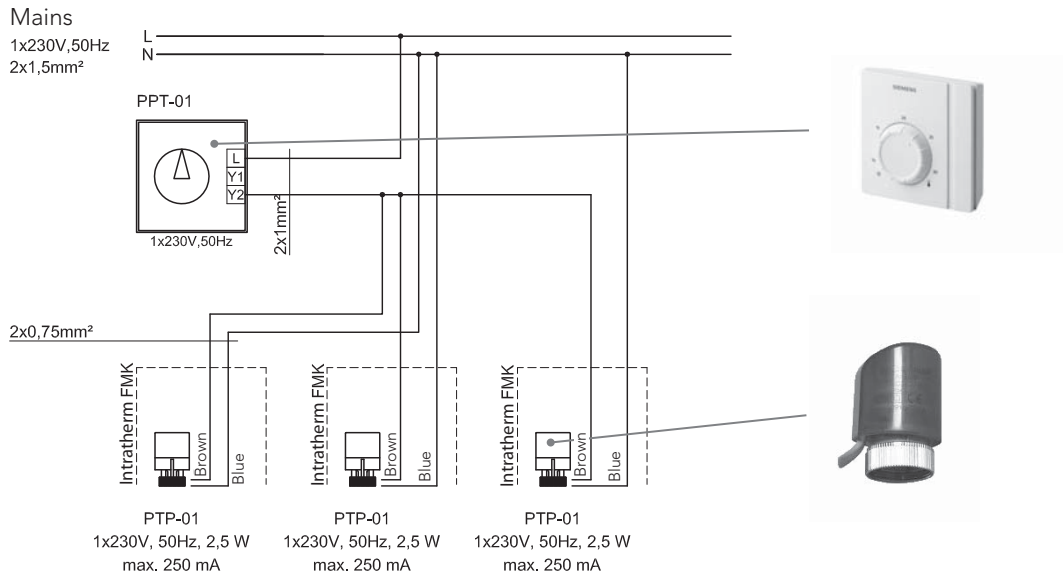

Block diagram no. 2 – Intratherm FMK, controlled with adjusting drive – PTP-02 (currentless closed)

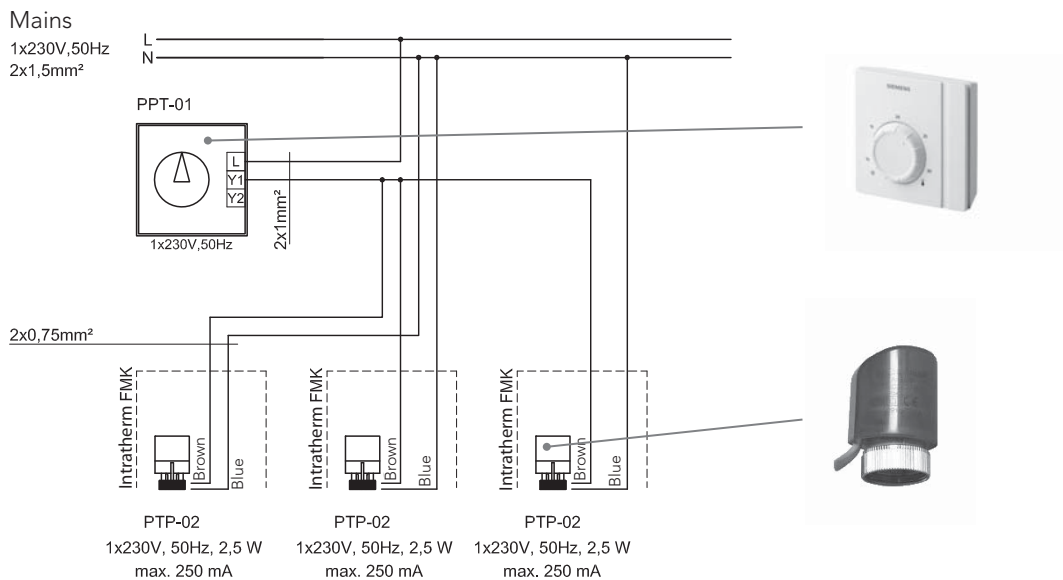

Note:

- 1) Always use a residual current device when using an adjusting drive.
- 2) A maximum of 24 adjusting drives can be connected to a single thermostat.

Intratherm – recommended circuit diagrams

Block diagram no. 3 – Intratherm F1T with the PPT-02 thermostat and the PAT-xx-M external transformer

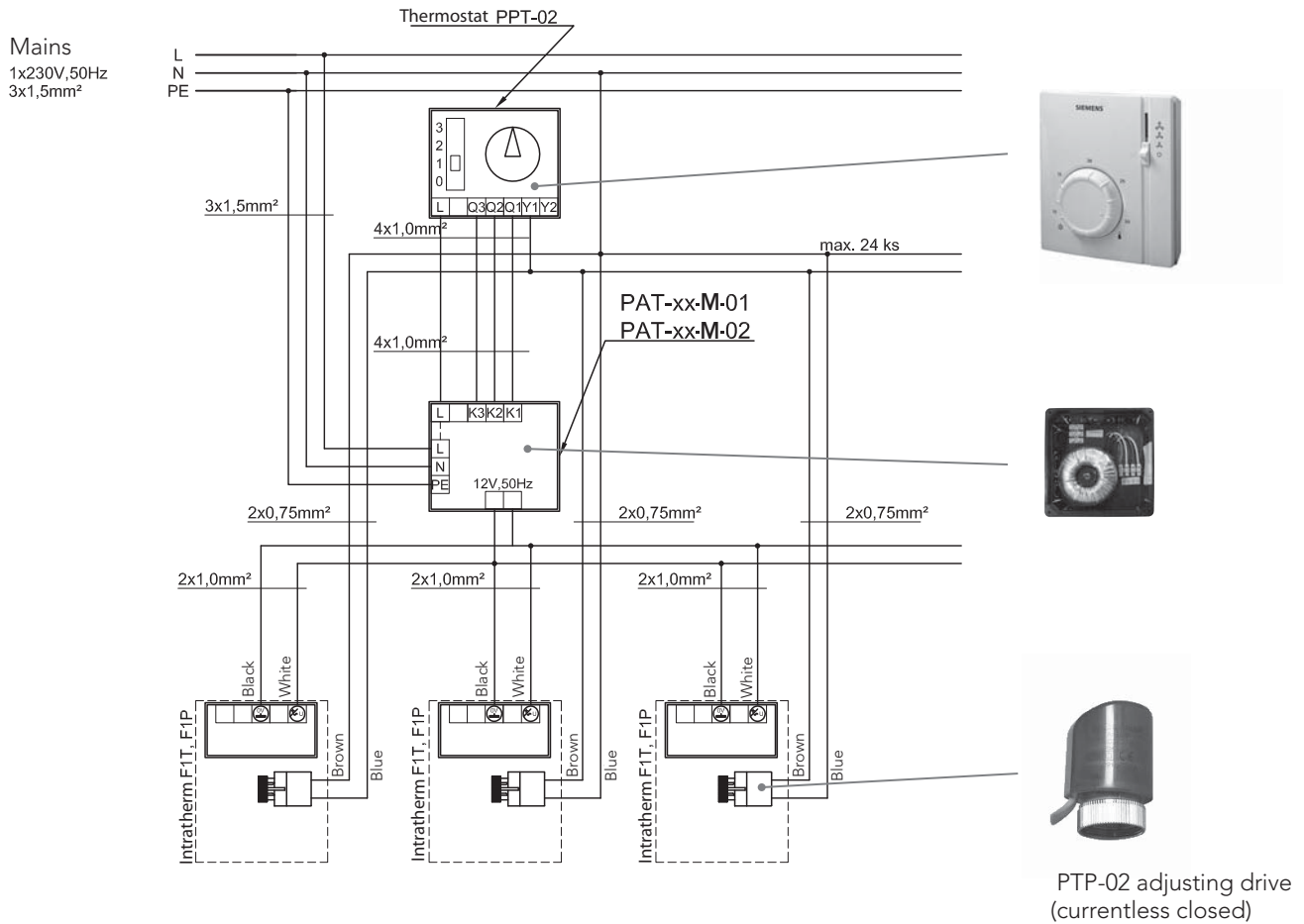

Note:

- 1) Always use a residual current device when using an adjusting drive
- 2) Observe the maximum number of connected fans per PAT controller
- 3) The circuit diagrams apply in the case of the flush-mounted version; in the case of the surface-mounted version, the PAT controllers are only connected with a two core cable.

Intratherm – recommended circuit diagrams

Block diagram no. 4 – Intratherm F1T with the PER-05 or PER-06 thermostat and the PAT-xx-M external transformer

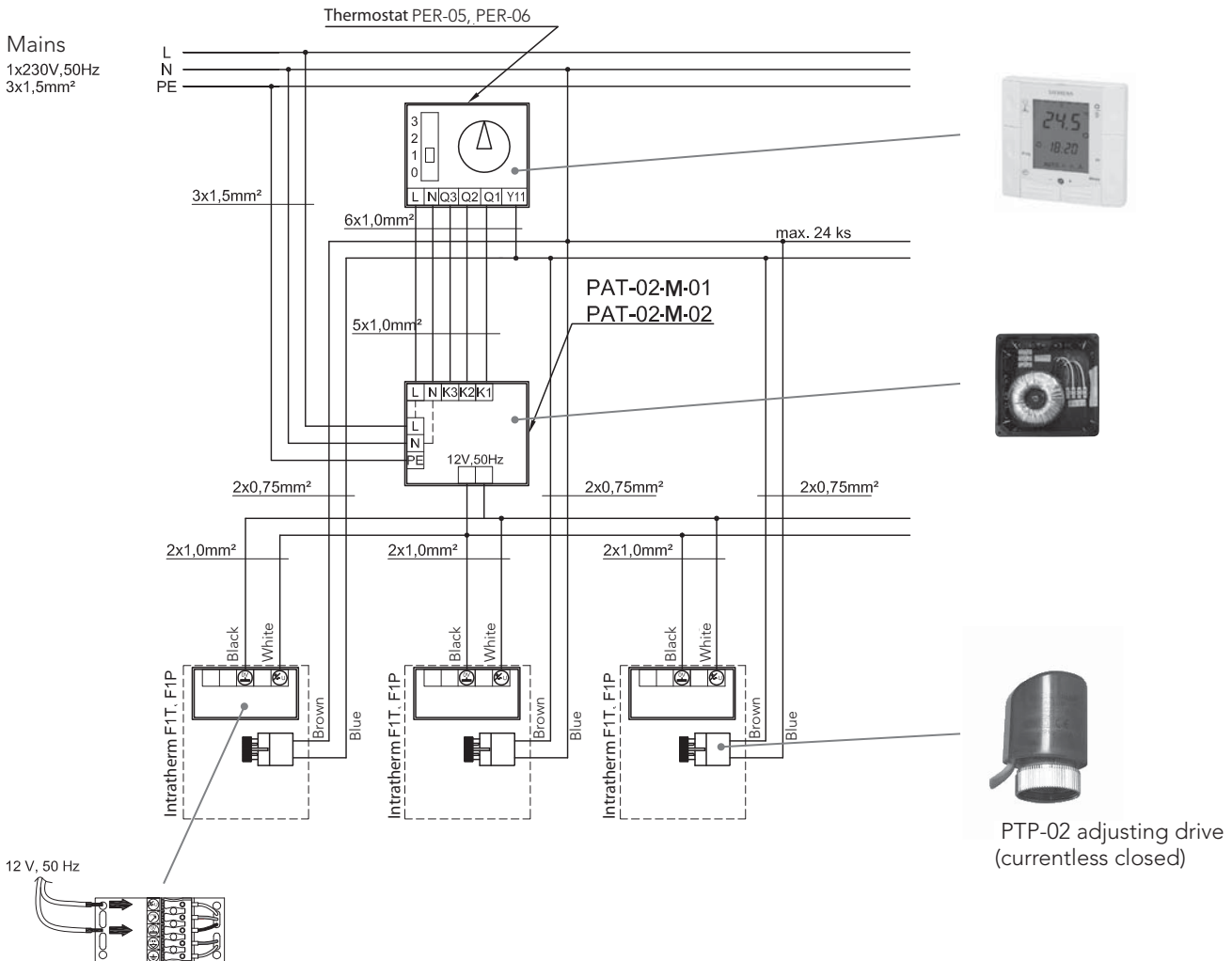

Block diagram no. 5 – Intratherm F1T, F1P – detailed diagram of the terminal block of the EC motors

12 V, 50 Hz

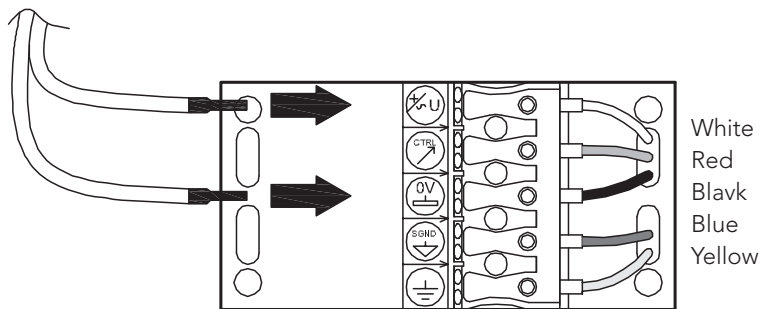

Intratherm – recommended circuit diagrams

Block diagram no. 6 – Intratherm F1T, F1P with PPT-02 thermostat and the PAT-xx-M external transformers (parallel operation of the transformers)

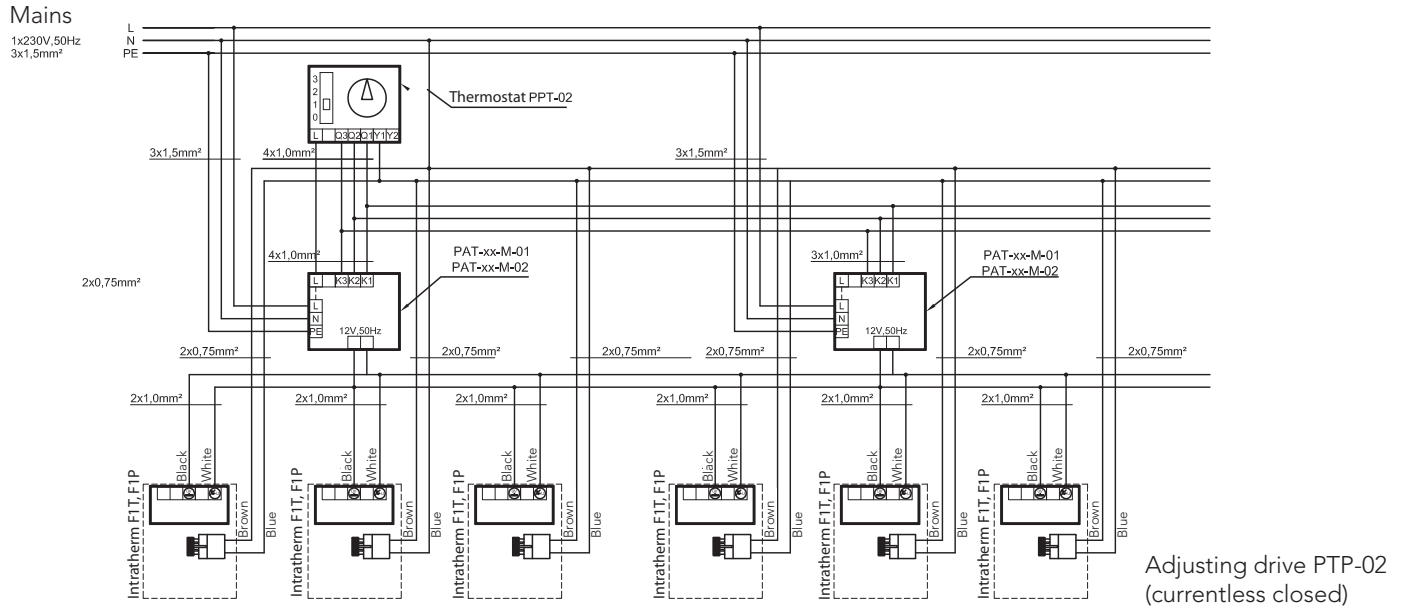

Block diagram no.7 – Intratherm F1T, F1P with PER-05 or PER-06 thermostats and the PAT-xx-M external transformers (parallel operation of the transformers)

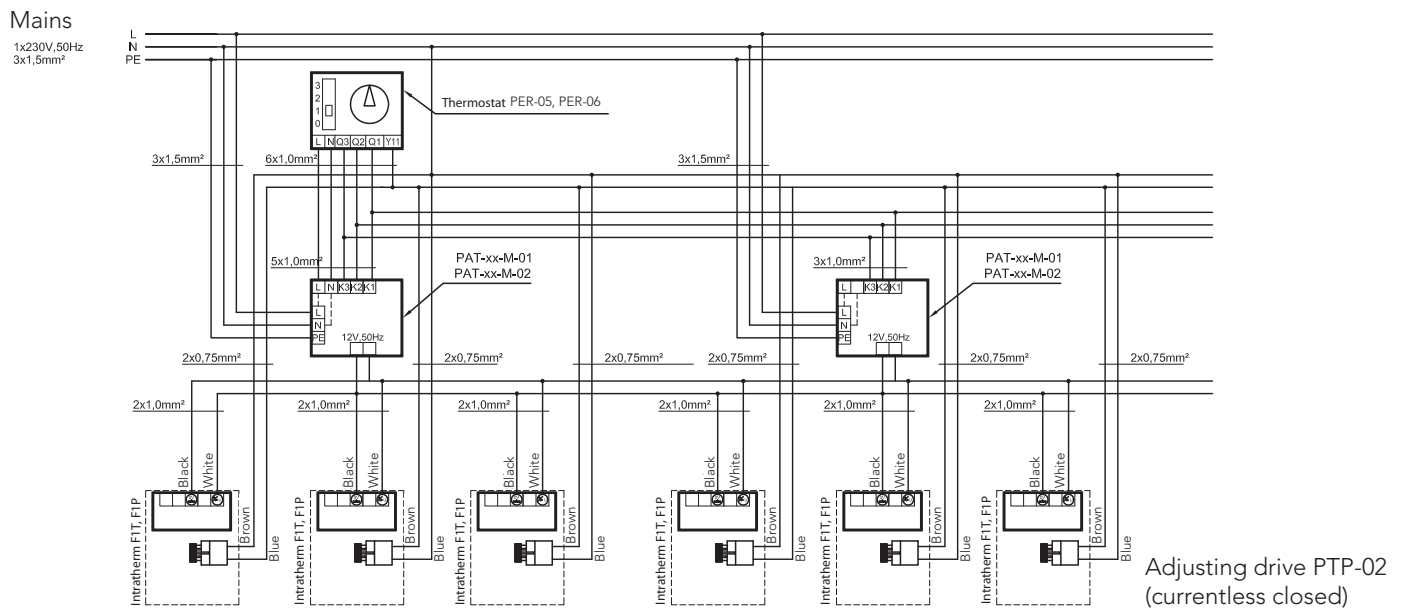

Intratherm – recommended circuit diagrams

Block diagram no. 8 – Intratherm F1T, F1P with the PPT-02 thermostat and the PAT-xx-T-04 controller, installed in the trench

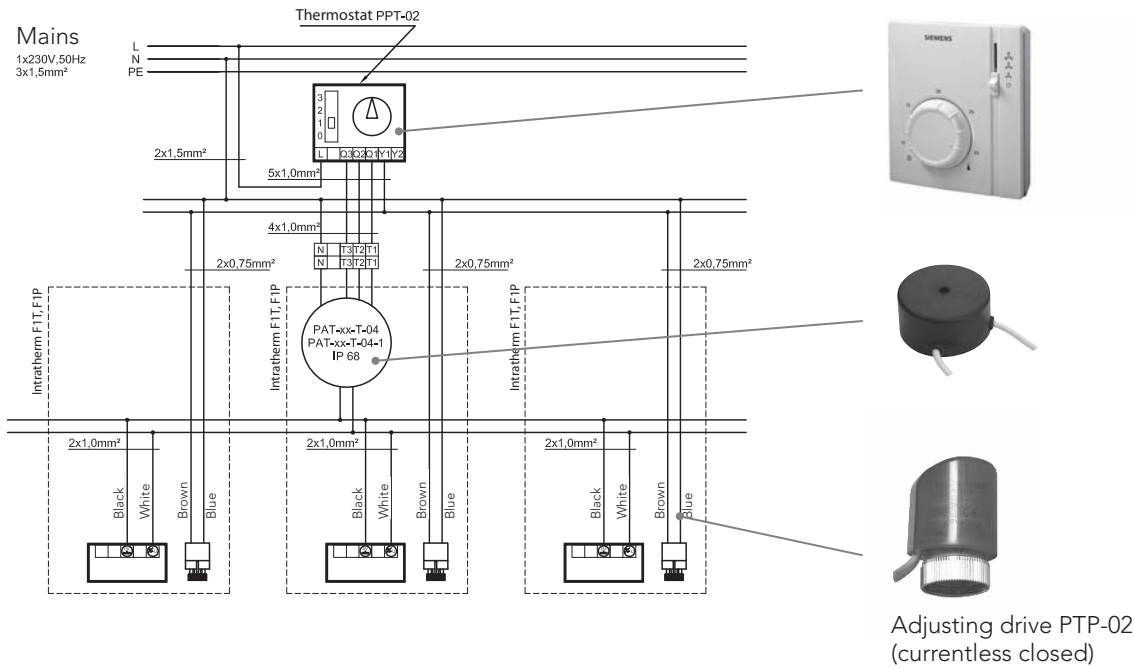

Block diagram no. 9 – Intratherm F1T, F1P with the PPT-02 thermostat, the PAT-RM control module and the PAT-xx-T-04 controller, installed in the trench

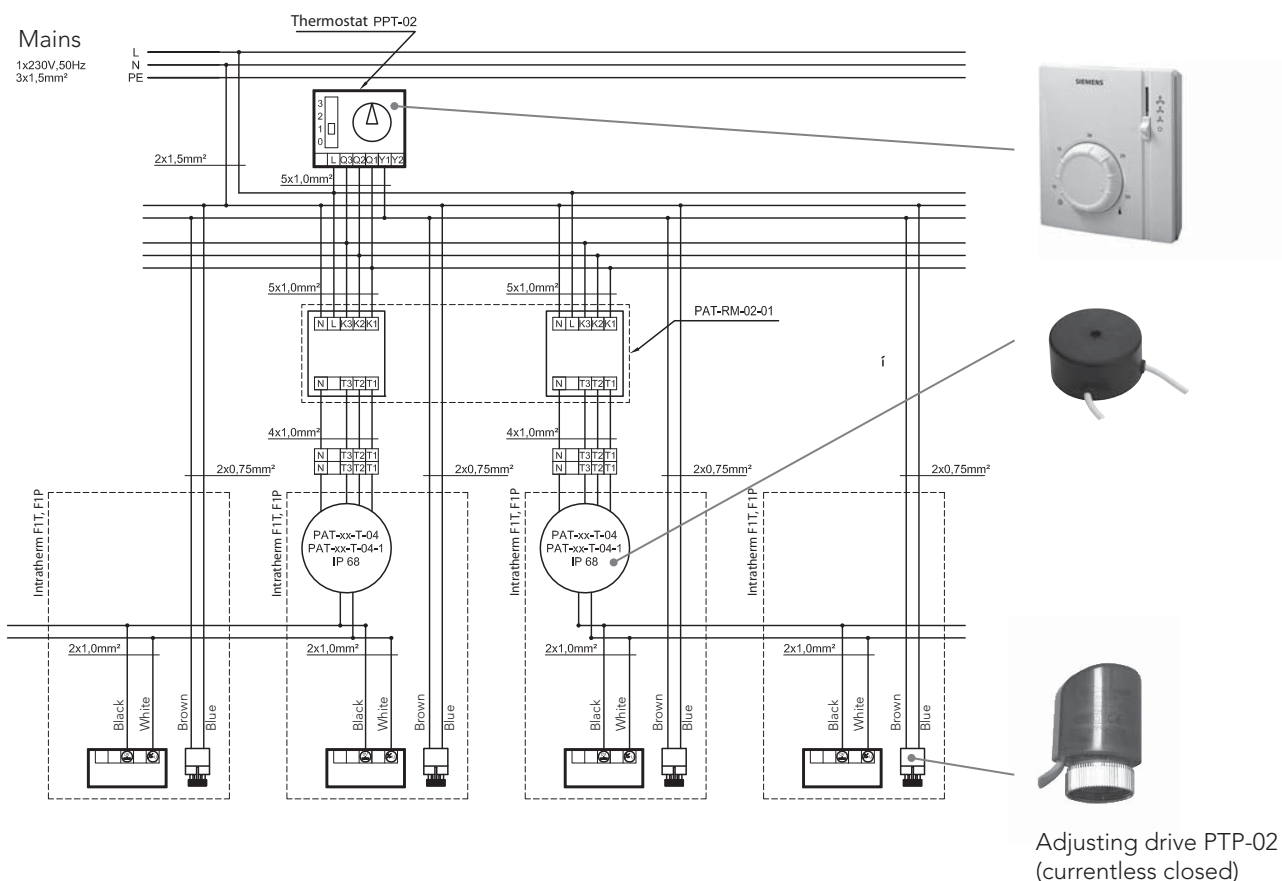

Intratherm – recommended circuit diagrams

Block diagram no. 10 – Intratherm F1T, F1P with the PER-05 or PER-06 thermostat, the PAT-RM control module and the PAT-xx-T-04 controller, installed in the trench

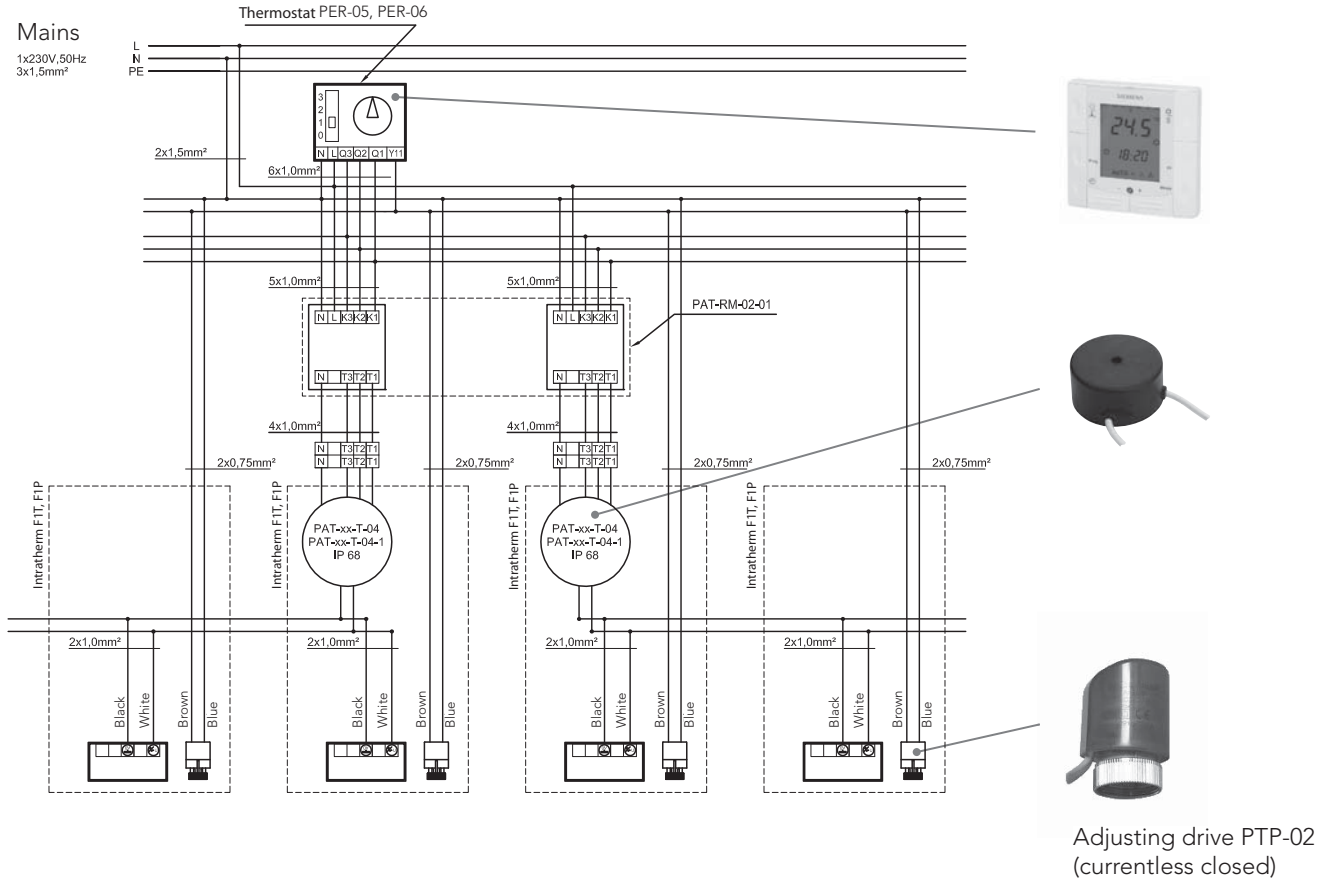

Note:

- 1) Observe the maximum number of connected fans per PAT controller
- 2) The PAT-xx-T controllers cannot be connected in parallel
- 3) The PAT-xx-T controllers cannot be operated using the PER-05 and PER-06 thermostats

Block diagram no. 11 – Intratherm F1T, F1P with an assembly allowing for limited use of a PTL-01 fan

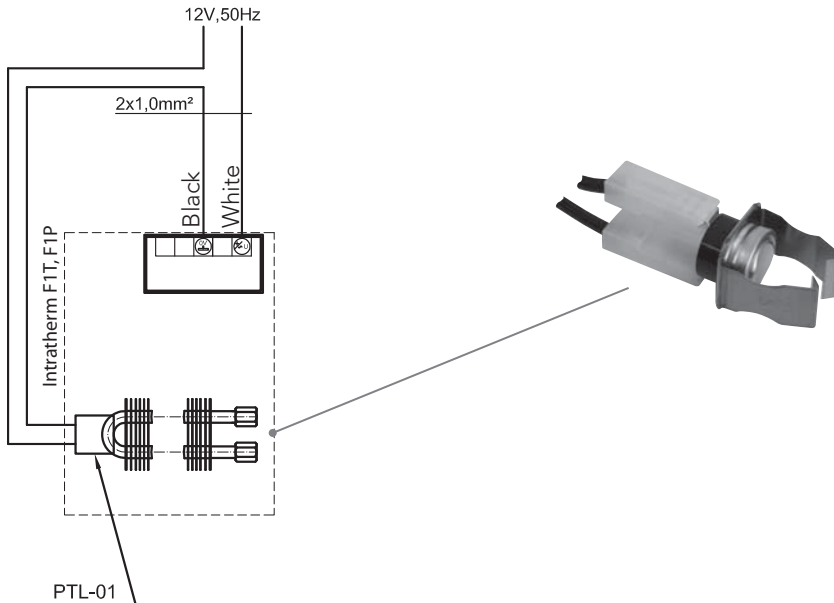

Fan cut-out when the hot water temperature falls below 35 °C. Installation directly at the heat exchanger.

Intratherm – recommended circuit diagrams

Block diagram no. 12

Speed controller: RAU-04-M-04 (max. 40 Watts)

- Installation in the convector trench
- Electric power max. 40 Watts (4 motors)
- Parallel switching is possible
- Operation by means of thermostat of the user's choice

These colour indications may vary.
Orientation according to the cable diagrams during installation.

- Q1...yellow
- Q2...orange
- Q3...brown
- L...black
- PE...green/yellow
- N...blue
- LS...red/not necessary

Mains

1x230V, 50 Hz
3x1,5mm²

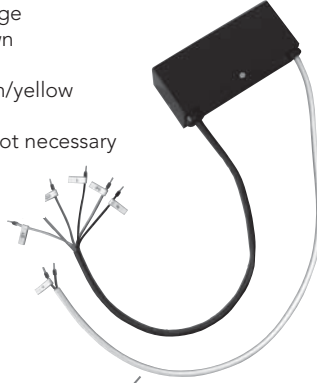
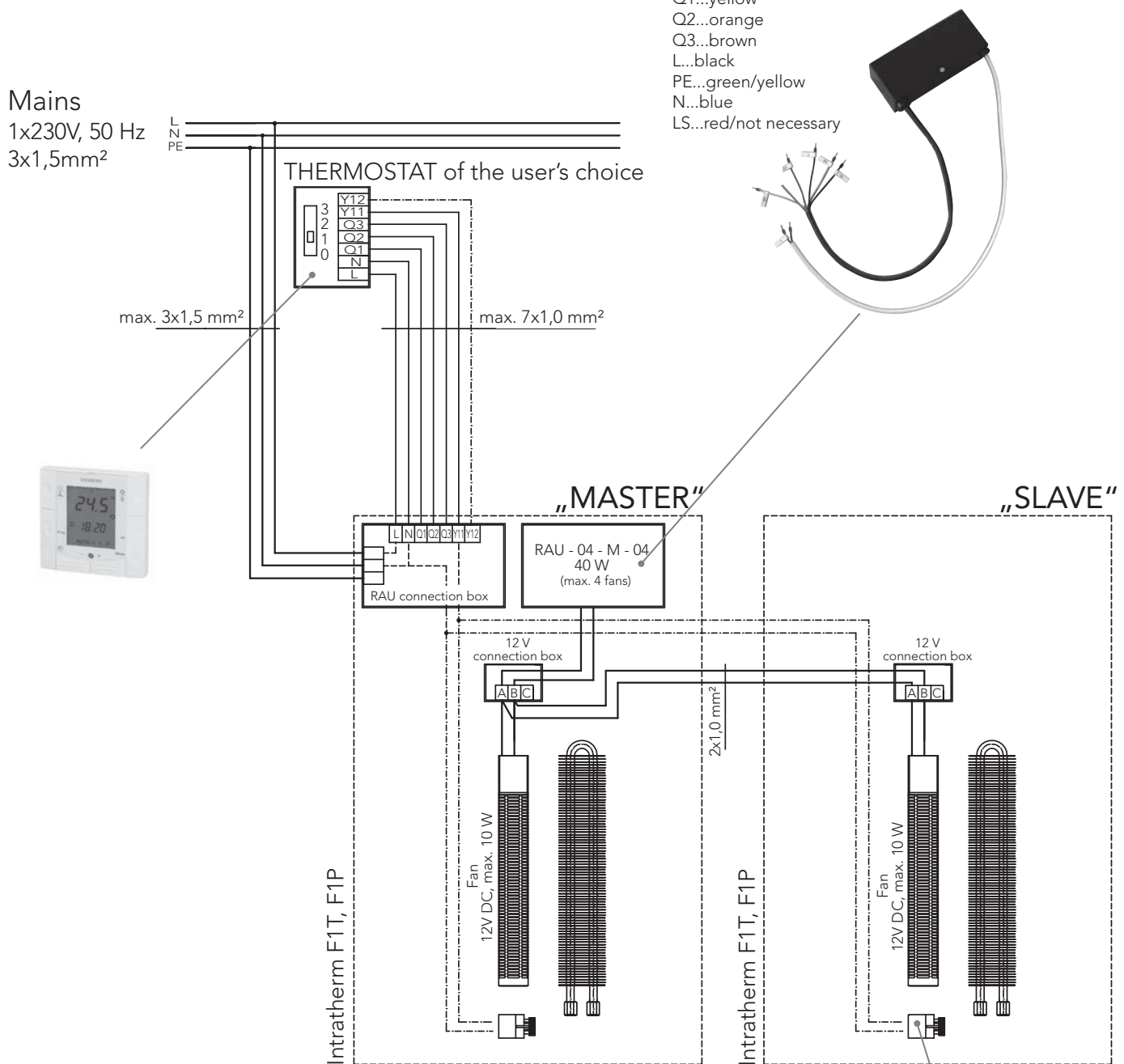

Adjusting drive PTP-02
1 x 230 V, 50 Hz, 2,5 W
max. 250 mA
(currentless closed)



Intratherm - empfohlene Schaltschemen

Block diagram no. 13

Parallel operation of the speed controller: RAU-04-M-04

- Installation in the convector trench
- For more than 4 motors
- Parallel switching is possible
- Operation by means of thermostat of the user's choice

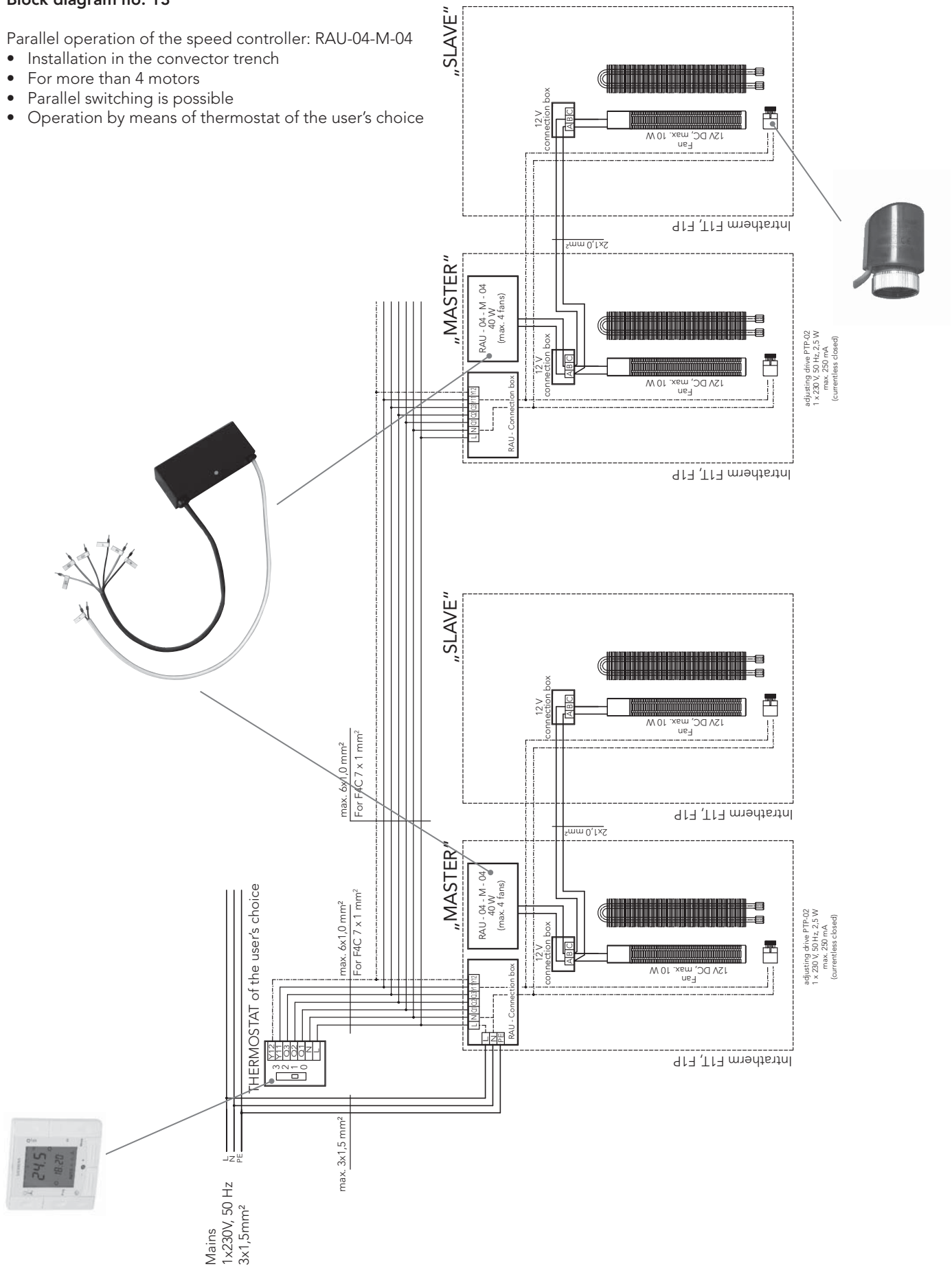

Intratherm – recommended circuit diagrams

Block diagram no. 14 – Intratherm F1T, F1P – Moisture-proof version

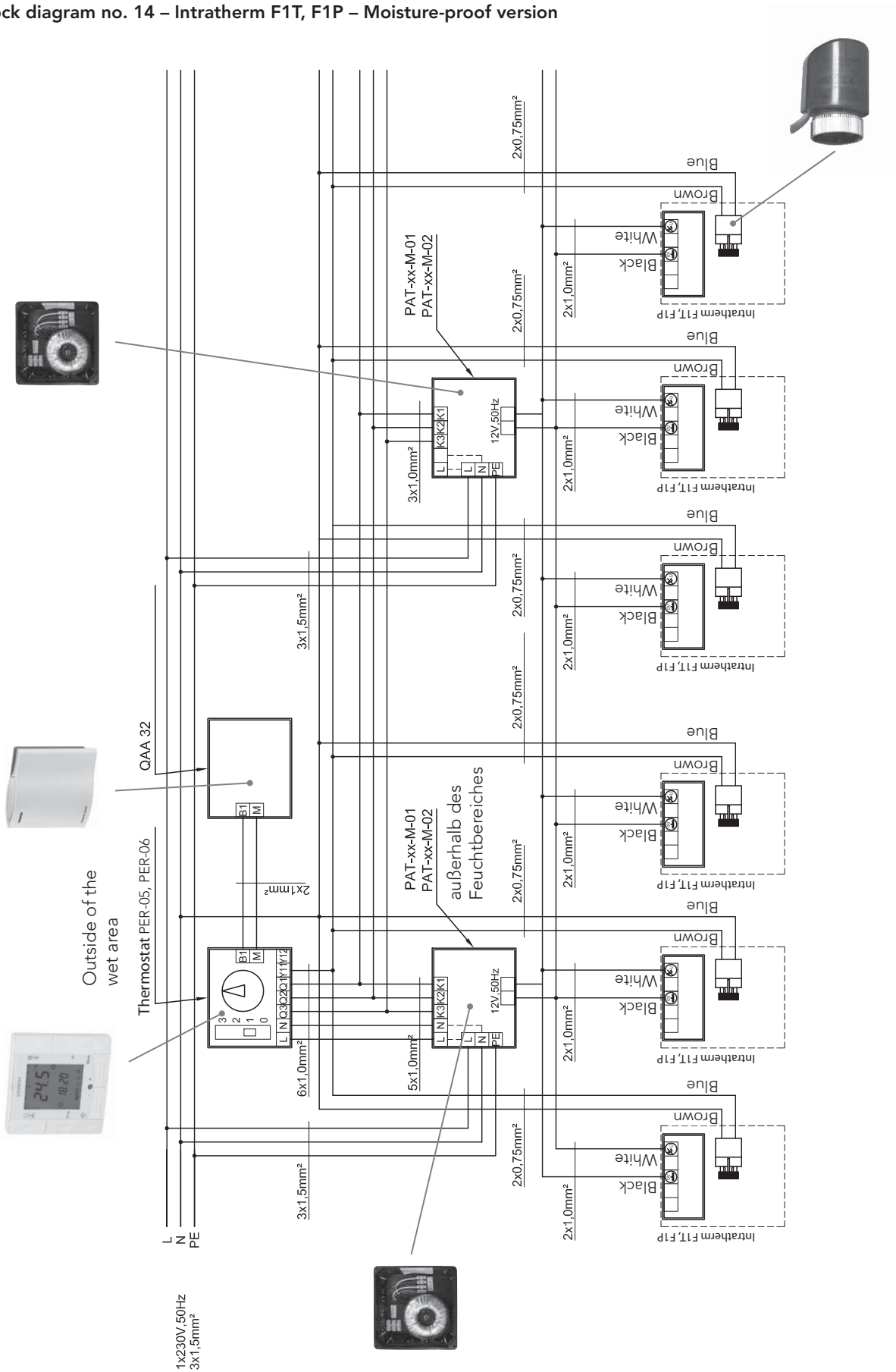

We reserve the right to amend typing errors and make technical changes. Valid from 1 February 2014.

352 INTRATHERM Trench convectors

Conversion table

Factor K1 for converting the heat output																									
Coefficient K1 for converting the heat output																									
Supply temperature (°C)	Air temperature (°C)	FMK convector – without fan; exponent n = 1.4																							
		35	40	45	50	55	60	65	70	75	80	85	Return temperature (°C)												
90	15	0,78	0,88	0,98	1,08	1,17	1,26	1,35	1,43	1,52	1,61	1,69		0,52	0,46	15	45								
	20	0,63	0,73	0,83	0,93	1,02	1,11	1,19	1,28	1,36	1,45	1,53		0,42	0,36	20									
	24	0,51	0,62	0,72	0,81	0,90	0,99	1,08	1,36	1,24	1,32	1,4		0,33	0,28	24									
85	15	0,73	0,83	0,93	1,02	1,11	1,19	1,28	1,36	1,45	1,53		0,62	0,57	0,51	15	50								
	20	0,59	0,69	0,78	0,82	0,96	1,05	1,13	1,21	1,29	1,37		0,52	0,46	0,40	20									
	24	0,47	0,58	0,67	0,76	0,85	0,93	1,01	1,09	1,17	1,25		0,44	0,38	0,32	24									
80	15	0,69	0,78	0,87	0,96	1,05	1,13	1,21	1,29	1,37		0,73	0,67	0,61	0,55	15	55								
	20	0,55	0,64	0,73	0,82	0,90	0,99	1,07	1,14	1,22		0,62	0,57	0,51	0,44	20									
	24	0,44	0,54	0,63	0,71	0,79	0,87	0,95	1,03	1,10		0,54	0,48	0,42	0,35	24									
75	15	0,64	0,73	0,82	0,90	0,99	1,07	1,14	1,22		0,84	0,78	0,72	0,66	0,59	15	60								
	20	0,51	0,60	0,69	0,77	0,85	0,92	1,00	1,07		0,73	0,67	0,61	0,55	0,48	20									
	24	0,40	0,50	0,58	0,66	0,74	0,82	0,89	0,96		0,64	0,59	0,53	0,46	0,39	24									
70	15	0,60	0,69	0,77	0,85	0,92	1,00	1,07		0,95	0,89	0,83	0,77	0,70	0,63	15	65								
	20	0,47	0,58	0,64	0,71	0,79	0,86	0,93		0,84	0,78	0,72	0,66	0,59	0,52	20									
	24	0,37	0,46	0,54	0,61	0,68	0,76	0,83		0,75	0,69	0,63	0,57	0,50	0,42	24									
65	15	0,56	0,64	0,71	0,79	0,86	0,93		1,06	1,00	0,94	0,88	0,81	0,74	0,67	15	70								
	20	0,43	0,51	0,59	0,66	0,73	0,80		0,95	0,89	0,83	0,77	0,70	0,63	0,55	20									
	24	0,33	0,41	0,49	0,56	0,63	0,70		0,86	0,80	0,74	0,68	0,61	0,54	0,46	24									
60	15	0,51	0,59	0,66	0,73	0,80		1,17	1,11	1,05	0,99	0,92	0,86	0,78	0,71	15	75								
	20	0,39	0,47	0,54	0,60	0,67		1,06	1,00	0,94	0,88	0,81	0,74	0,67	0,59	20									
	24	0,30	0,37	0,44	0,51	0,57		0,97	0,91	0,85	0,79	0,72	0,65	0,58	0,49	24									
55	15	0,47	0,54	0,60	0,67		1,28	1,22	1,16	1,10	1,04	0,97	0,90	0,83	0,75	15	80								
	20	0,35	0,42	0,49	0,55		1,17	1,11	1,05	0,99	0,92	0,86	0,78	0,71	0,62	20									
	24	0,27	0,33	0,40	0,46		1,08	1,02	0,96	0,90	0,83	0,77	0,89	0,61	0,52	24									
50	15	0,42	0,49	0,55		1,40	1,34	1,28	1,21	1,15	1,08	1,01	0,94	0,87	0,78	15	85								
	20	0,31	0,37	0,43		1,28	1,22	1,16	1,10	1,04	0,97	0,90	0,83	0,75	0,66	20									
	24	0,23	0,29	0,35		1,19	1,13	1,07	1,01	0,95	0,88	0,81	0,73	0,65	0,56	24									
45	15	0,37	0,43		1,51	1,45	1,39	1,33	1,26	1,20	1,13	1,06	0,98	0,91	0,82	15	90								
	20	0,27	0,33		1,40	1,34	1,28	1,21	1,15	1,08	1,01	0,94	0,87	0,78	0,69	20									
	24	0,19	0,25		1,30	1,25	1,19	1,12	1,06	0,99	0,92	0,85	0,77	0,68	0,59	24									
Return temperature (°C)													85	80	75	70	65	60	55	50	45	40	35	Air temperature (°C)	Supply temperature (°C)
F1T and F1P convector with fan; exponent n = 1.1																									

Example:

FMK-26-100-11, heat output for 75/65/20 °C: QN = 266 W, flow temperature: 50 °C,

return temperature: 45 °C, air temperature: 24 °C, correction factor K1 = 0.35

Corrected heat output for 50/45/24 °C: QS x K1 = 266 W x 0.35 = 93 W

Intratherm pressure losses

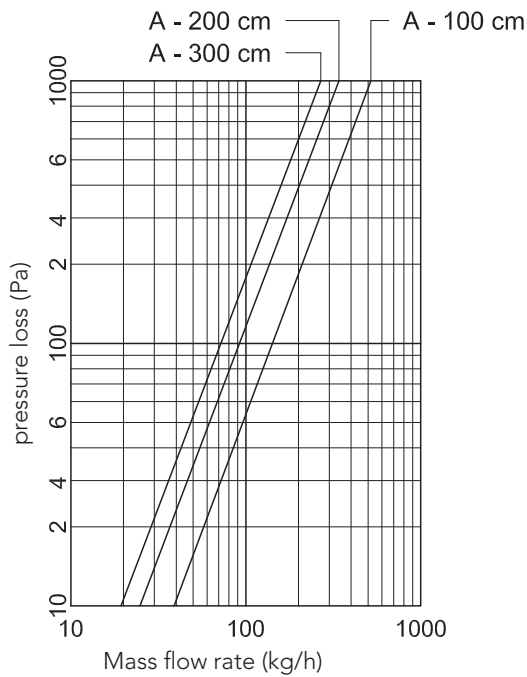

- 1 FMK-18-LLL-09, FMK-18-LLL-11
- 2 FMK-26-LLL-09, FMK-26-LLL-11
- 3 FMK-29-LLL-09, FMK-29-LLL-11
- 4 F1T-26-LLL-09
- 5 LVF-09-LLL-10, LVF-09-LLL-11

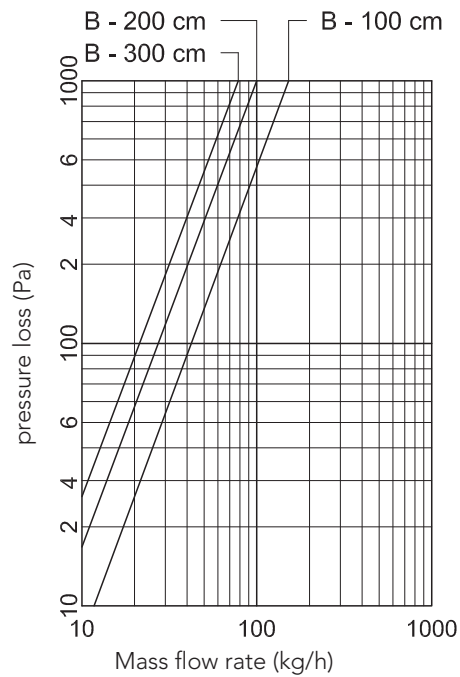

- 1 FMK-34-LLL-09, FMK-34-LLL-11
- 2 F1T-29-LLL-09
- 3 LVF-14-LLL-10, LVF-14-LLL-11

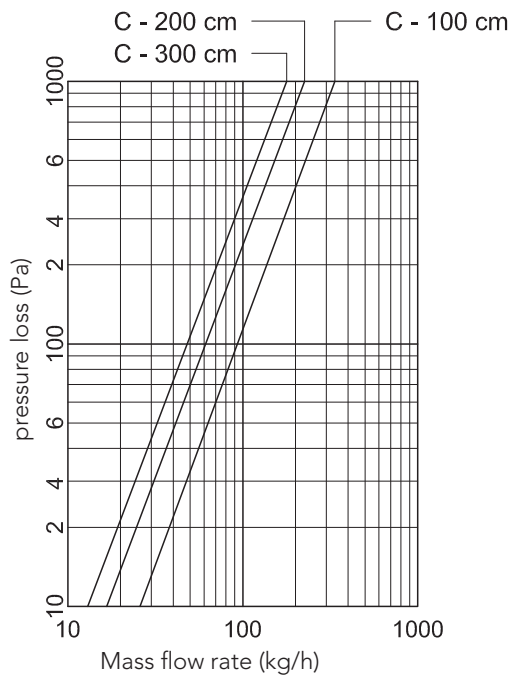

- 1 FMK-42-LLL-09, FMK-42-LLL-11
- 2 F1T-34-LLL-09
- 3 FMK-18-LLL-14
- 4 FMK-26-LLL-14, F1T-26-LLL-14
- 5 LVF-19-LLL-10, LVF-19-LLL-11
- 6 LVR-10-LLL-10, LVR-10-LLL-11

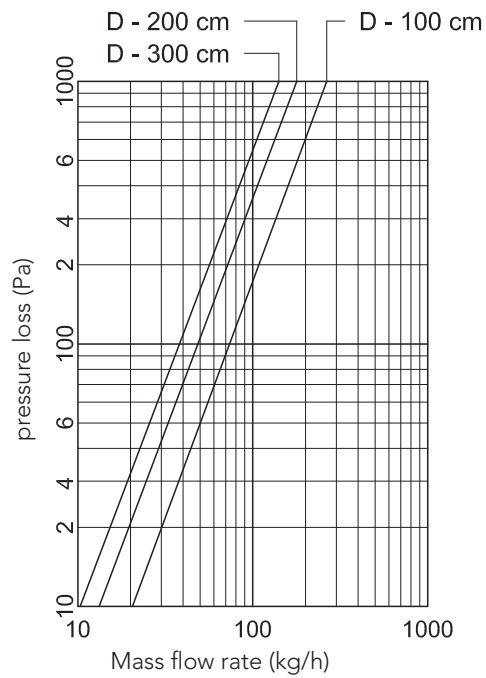

- 1 FMK-34-LLL-14
- 2 F1T-29-LLL-14
- 3 LVR-15-LLL-10, LVR-15-LLL-11

LLL = Total length of convector in cm

Intratherm pressure losses

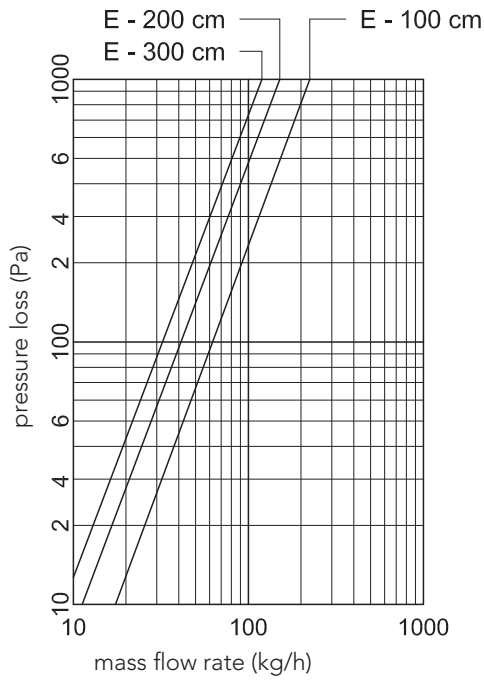

- 1 FMK-42-LLL-14
- 2 F1T-34-LLL-14
- 3 LVR-20-LLL-10, LVR-20-LLL-11

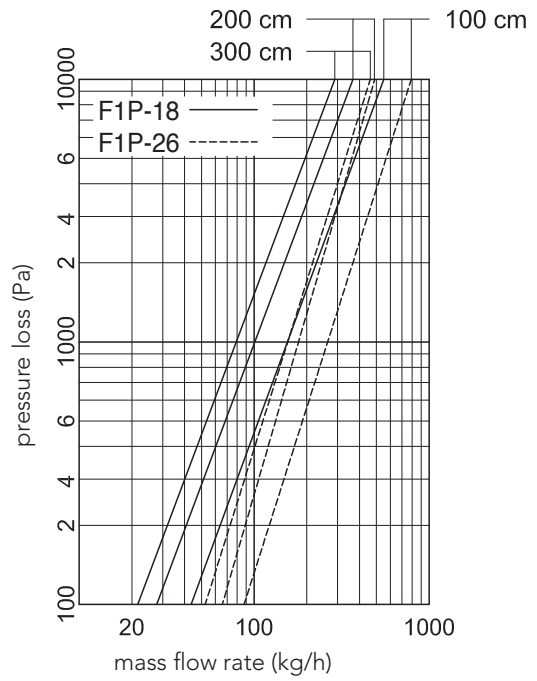

- 1 F1P-18-LLL-09
- 2 F1P-26-LLL-11

Installation of the floor convectors

Recommended installation of the convector with embedding of the trench in concrete

- 1) Prepare the convector for installation by placing the anchors with the screws in the drill holes provided and pushing out the openings for the pipework and cable feed. The rubber bushings are then fitted.
- 2) Place the trench onto the unfinished floor and position it using the adjustable screws (M8 x 30) or the anchor brackets in such a way that the top of the convector lies at the level of the floor including the screed (horizontal alignment of the trench). Attention: if using the Z-frame, the trench must be laid 3-5 mm below the level of the finished floor!
- 3) Use insulation (upon request) for the purpose of noise reduction and heat insulation
- 4) Connect the heat exchanger to the pipelines and carry out electrical installation.
- 5) For the moisture-proof version, connect the drainage facility in the trench floor to the drain.
- 6) Carry out another pressure test and test the functioning of the fans
- 7) Check the correct fit of the trench again
- 8) The wooden cover plate is refitted in the trench
- 9) Then embed the trench in concrete: the entire area underneath and around the convector trench up to approximately 1/3 of the height of the trench is filled evenly with light concrete; there must be no air bubbles remaining underneath the convector trench, as these are the cause of sound reverberation; the floor of the trench must lie on top of a concrete base layer. The remaining uncovered area is to be filled evenly with screed.
- 10) Only remove the wooden cover plate once all works have been completed
- 11) Fit the grille on top of the convector

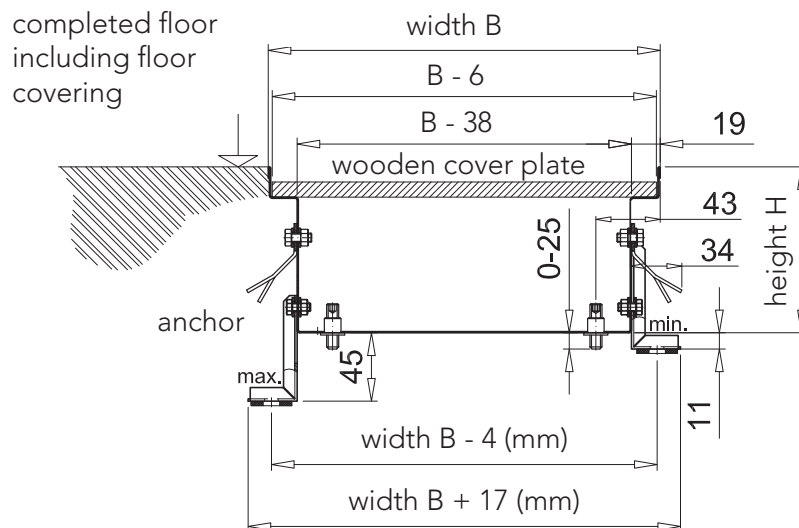

Installation of the floor convector

Recommended installation of the convector in the cavity floor using footfall impact-resistant height adjustment

- 1) The position of the drill hole (anchor bolt) is marked on the base
- 2) The footfall impact-resistant height adjustment is fitted onto the convector trench
- 3) The openings for the pipework and cable feed are pushed out and the rubber bushings are then fitted
- 4) Place the trench onto the unfinished floor and position it using the footfall impact-resistant height adjustment in such a way that the top of the convector lies at the level of the floor including the screed (horizontal alignment of the trench).

Attention: If using the Z-frame, the trench is to be laid 3-5 mm below the level of the finished floor!

- 5) Use insulation (upon request) for the purpose of noise reduction and heat insulation
- 6) Connect the heat exchanger to the pipelines and carry out electrical installation.
- 7) For the moisture-proof version, connect the drainage facility in the trench floor to the drain.
- 8) Carry out a pressure test and test the functioning of the fans
- 9) Check the correct fit of the trench again
- 10) The wooden cover plate is refitted in the trench
- 11) Only remove the wooden cover plate once all works have been completed
- 12) Fit the grille on top of the convector

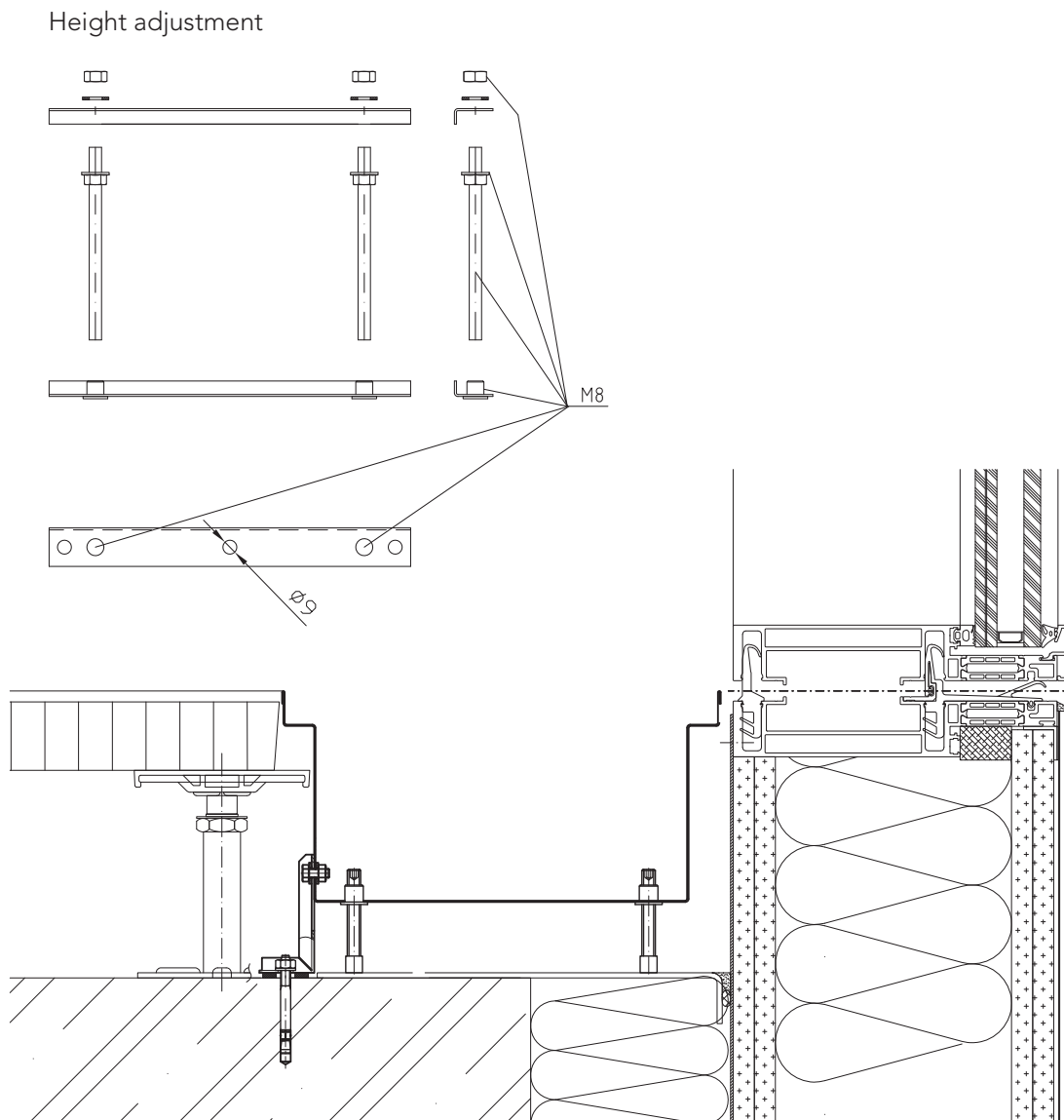

Installation of the floor convector

Recommended installation of the moisture-proof version

The installation of convectors in a moisture-proof version proceeds according to the previously-listed points (see pages 343, 344)

- 1) The convector trench, the trench components and the grille are manufactured from corrosion-proof material
- 2) All joints on the trench are sealed with bathroom silicone sealant.
- 3) The floor of the convector trench is equipped with a drainage facility (see drawing below)
- 4) The waste water pipe must be fitted at an ensured gradient.
- 5) It is recommended that the installer should fit the water drain with an odour trap
- 6) The thermostat and the transformer must be fitted outside of the wet area
- 7) The electrical components must be connected via a residual current device

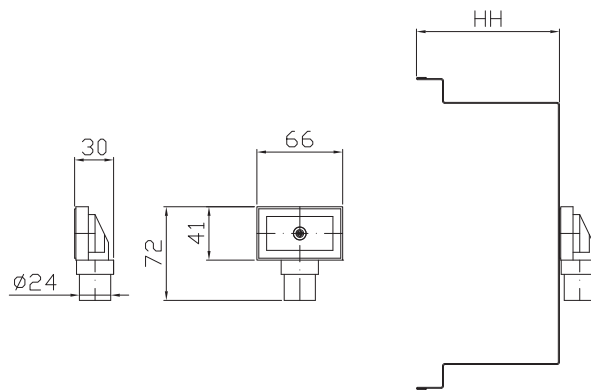

Definition of operating conditions

The operating conditions of Intratherm convectors have been defined as follows:

- Max. operating overpressure (10 bar)
- Maximum water operating temperature 110 °C
- Installation of the floor convectors in the enclosed hot water system
- Safe voltage of fan drives installed in the standard way is 12 V
- Defined non-corrosive and non-saline composition of swimming pool water

Maintenance and cleaning

- Remove dirt from the convector trench (vacuum clean, wipe down) periodically (before and after the heating season as a minimum)
- Clean the heat exchanger with a soft brush
- Remove dust on the floor of the housing with a vacuum cleaner
- Remove any other dirt using a damp cloth
- Check the waste water drain on the floor of the trench in the moisture-proof version
- Check the functioning of the individual fan drives while not in use for extended periods (prior to the heating season)

Recommended measures in the event of reduced output

Check:

- The installation of the heat exchanger (horizontal position)
- The supply temperature in the heat exchanger
- The ventilation of the heat exchanger
- The circulation of hot water in the system (function of the system pump)
- The settings of the thermostatic valve, the thermostatic head, the lockshield valve
- The functioning of the fans

Recommended connection examples

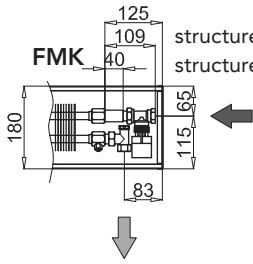

structure width 180 mm
structure height 90, 110, 140 mm

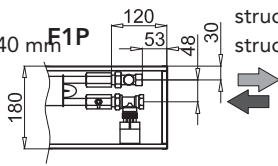

structure width 180 mm
structure height 90 mm

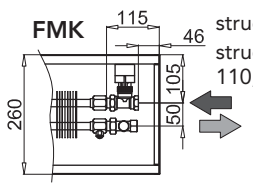

structure width 260 mm
structure height 90, 110, 140 mm

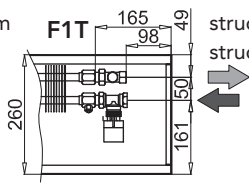

structure width 260 mm
structure height 90, 140 mm

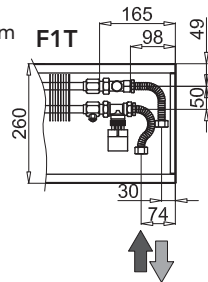

structure width 260 mm
structure height 90, 140 mm

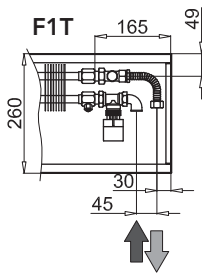

structure width 260 mm
structure height 90, 140 mm

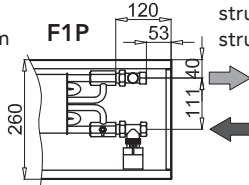

structure width 260 mm
structure height 90 mm

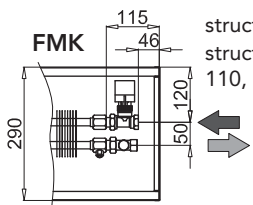

structure width 290 mm
structure height 90, 110, 140 mm

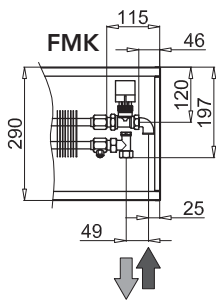

structure width 290 mm
structure height 90, 110, 140 mm

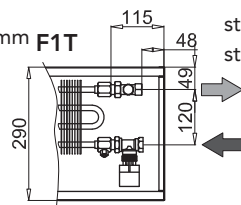

structure width 290 mm
structure height 90 mm

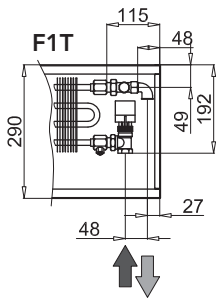

structure height 90 mm

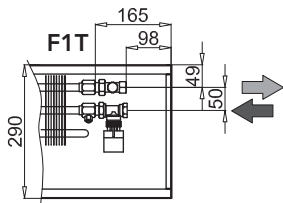

structure width 290 mm
structure height 140 mm

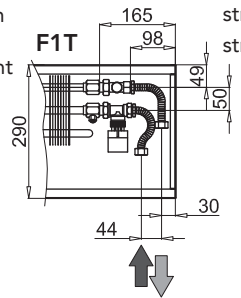

structure width 290 mm
structure height 140 mm

Recommended connection examples

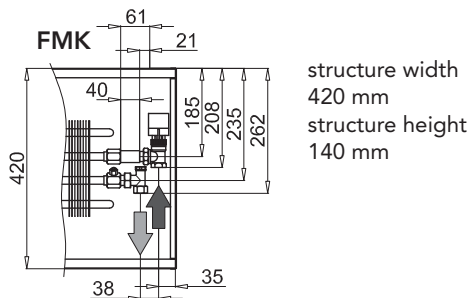
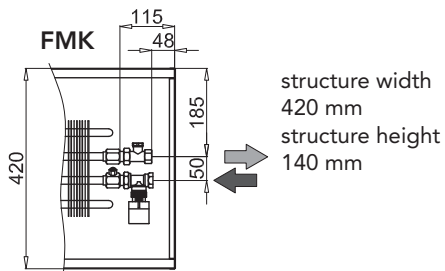
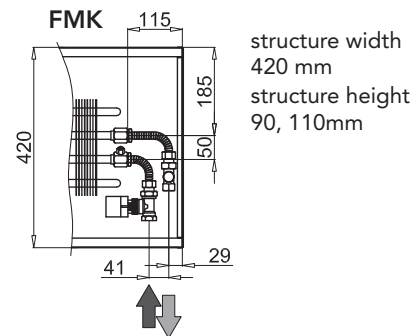
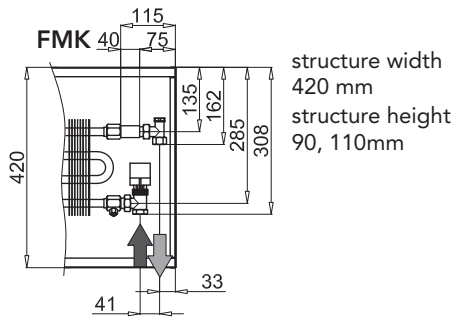
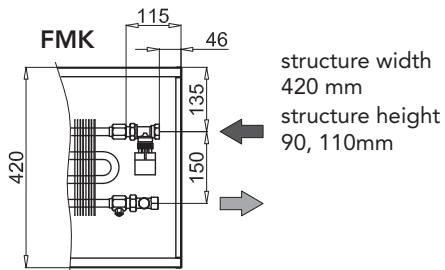
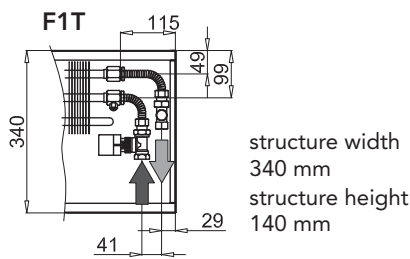
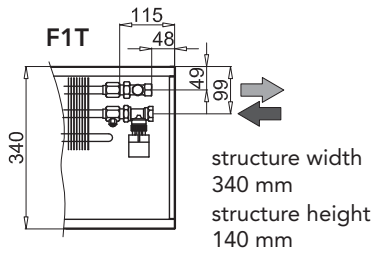
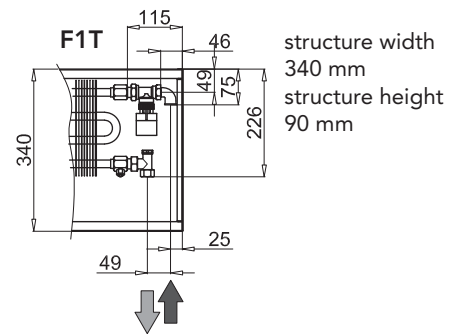
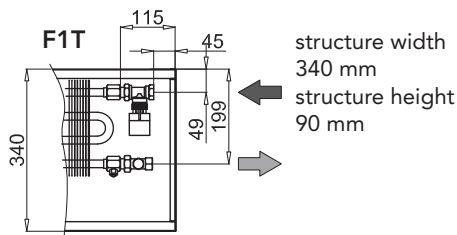
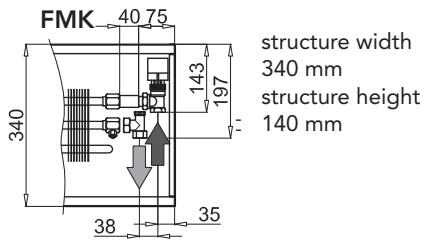
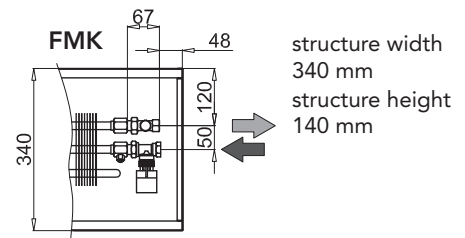
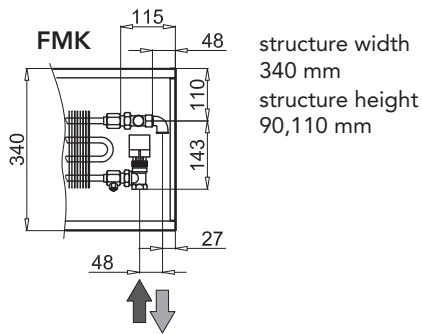
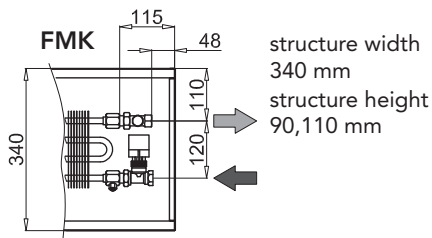

heatingthrough**innovation.**