

Technical Information 1/2008

Convectors & heating panels

heatingthrough**innovation.**

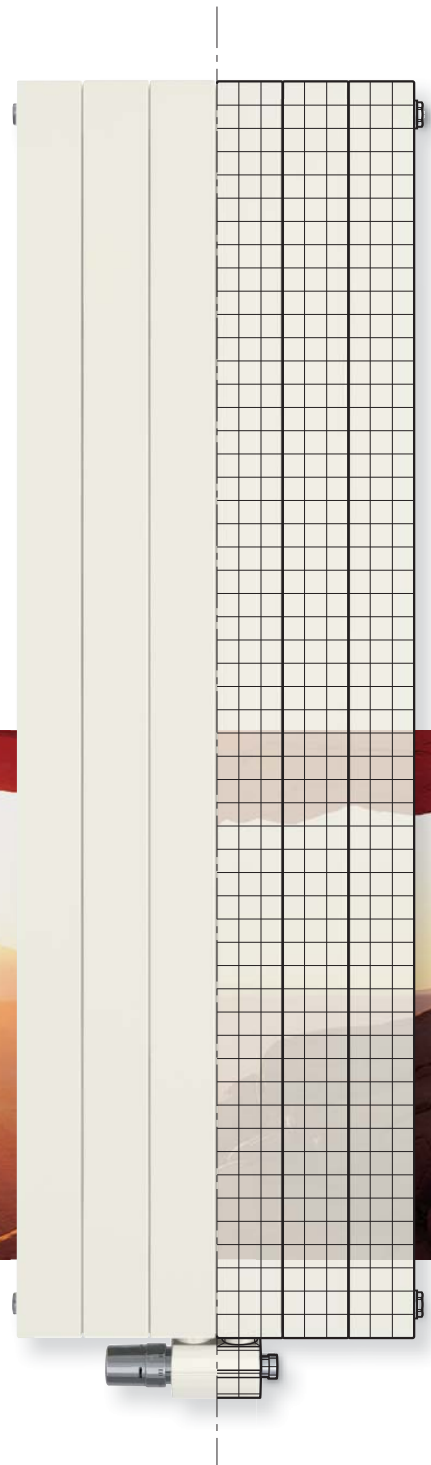



VONARIS.

In the **VONARIS** you get a ready-to-connect Designer product, that really keeps its promises, with the enormous versatility of its heat output, available dimensions and variety of colours.

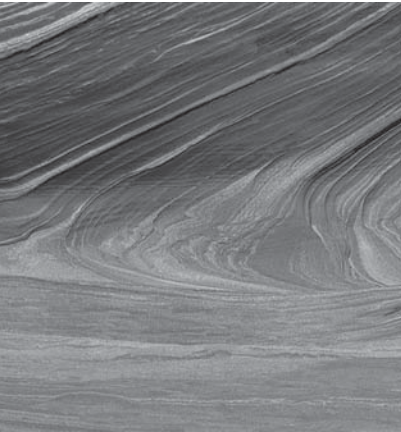

VONARIS-M.

The newly developed central-connection **VONARIS-M** offers an exemplary fast and inexpensive pre-installation, as well as the greatest possible freedom when installing the radiator.



KONTEC.

KONTEC convectors and wall-panels stand for aesthetically sophisticated Design, combined with technologically perfect heating. They were conceived with all areas of installation and use in mind.

BASICS.

Overall length	Overall height	Supply	Return	Pipe or boss spacing	Dummy plug	Air vent	Drain	Maximum positive operating pressure Standard design	Maximum positive operating pressure High-pressure design	Operating temperature	Connection	Overall depth

The pictograms given above will serve as a picture language to accompany you through this technical catalogue. They will help you recognise details and operational features at a glance.

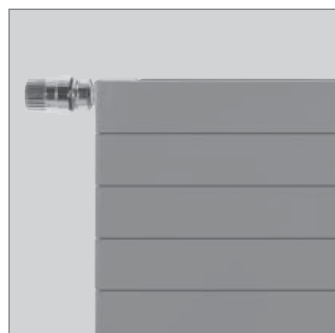

Product description	04
Model overview / VHV connection dimensions	05
WVO design	06
Model overview / VSV connection dimensions	07
Ordering process	08 - 09
Connection modes	10 - 13
Heat reflectors	14
VONOMAT welded bracket positions	15
VONOMAT drilling measurements and wall-clearance	16
VONOFIX positions of the insertion (push-in) brackets	17
VONOFIX drilling measurements and wall-clearance	18
Welded bracket positions	19
Installation consoles	20 - 21
Heating outputs	22 - 41

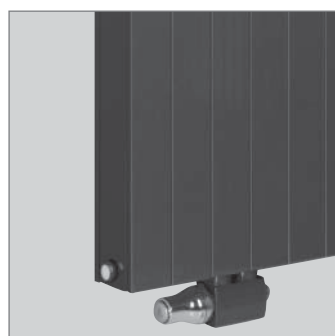

Product description	42
Model overview / VHV-M connection dimensions	43
Model overview / VSV-M connection dimensions	44
Ordering process	45 - 46
Two-pipe operation	47 - 49
Single-pipe operation	50 - 51
VONOMAT welded bracket positions	52
VONOMAT drilling measurements and wall-clearance	53
VONOFIX bracket positioning	54
VONOFIX drilling measurements and wall-clearance	55
Welded bracket positions	56
Stand consoles	57
Heating outputs	58 - 70



Product description	71
Model overview / KK connection dimensions	72
WVO design	73
Model overview / KH connection dimensions	74
Model overview / KS connection dimensions	75
Ordering process	76 - 78
Connection modes	79 - 81
Heat reflectors	82
VONOMAT welded bracket positions	83 - 84
VONOMAT drilling measurements and wall-clearance	85
Welded bracket positions	86
Installation consoles	87 - 88
Heating outputs	89 - 111

Calculation table	112
Installation dimensions	113 - 115
Texts for tenders	116 - 118
Guide for V fastening systems	119 - 121
Guide for M fastening systems	122 - 123
Guide for K fastening systems	119 - 121
Special designs / heat-reflectors	127
Accessories V / M / K	128 - 135
Order forms	136 - 138
Colours	139

VONARIS solitary finished radiator

VONARIS: the solitary finished radiator in a fully welded horizontal design, with 1 to 4 layers of steel rectangular water-flow pipes arranged one-behind-the-other, each layer consisting of from 2 to 11 pipes arranged one-above-the-other.

Vertical design: with 1 or 2 layers of steel rectangular water-flow pipes, arranged one-behind-the-other, each layer consisting of from 3 to 12 steel pipes, arranged side-by-side.

A 2 mm space between the heating pipes guarantees additional resistance to corrosion. **VONARIS** solitary finished radiators are equipped with a built-in valve set, suitable for either double-pipe or single-pipe operation, using a one-pipe manifold, with a factory-fitted valve (already installed) and protective cap.

VONARIS solitary finished radiators will normally be delivered with side panels. The horizontal design is also equipped

with a top cover. **VONARIS** solitary finished radiators, are not delivered with brackets as standard (exception: VHV 11, overall height 358 to 790 mm, does include brackets). For the vertical design, brackets are included. The **VONARIS** solitary finished radiator comes with a drain plug and a pivoting vent plug (with the vertical design, a dummy plug too), all of them factory-sealed.

VONARIS solitary finished radiators are Design radiators that are just waiting to be connected.

Standard design: rectangular steel pipes, 70 x 11 x 1.5 mm

High-pressure design: rectangular steel pipes, 70 x 11 x 2.0 mm

WVO design: models 22, 34 and 47 (in the horizontal design and up to an overall height of 286 mm) are also available with a rear-welded heat reflector (no water-flow). The VHV 20 model (at overall heights of 358 to 574 mm), and the VHV 22 model (overall heights 358 to 646 mm) may have a heat reflector fitted subsequently.

Dimensions:

Horizontal design: overall lengths between 500 mm and 1400 mm are available (at increments of 100 mm), and between 1600 and 4000 mm (at increments of 200 mm).

Horizontal design:
the available overall heights are
142, 214, 286, 358, 430, 502, 574, 646, and 790 mm.

Vertical design: overall lengths between
214 and 862 mm are available (at increments of 72 mm)

Vertical design: overall heights of 1600, 1800, and 2000 mm are available.

Coatings:

1. Undercoat: electrophoretic, using water-soluble paints, conforming to DIN 55900 part 1, stoved at 165° C;
2. Finish: electrostatic powder coating, conforming to DIN 55900 part 2, in a state-of-the-art facility. (On request, and at a supplementary charge, a range of RAL and sanitary ware colours can be offered.) This particularly robust coating is stoved at an object temperature of 180° C.

Packaging:

1. Cardboard packaging
2. Edge protection
3. Shrink foil

**Connections:**

horizontal design:
3 x internal thread G 1/2", and
2 x external thread G 3/4",
bottom right (by special order,
bottom left). Types VHV 20,
VHV 22, VHV 34, and VHV 46
are reversible and so can be
connected either at bottom
right or at bottom left.

vertical design:
4 x internal thread G 1/2", and
2 x external thread G 3/4",
bottom right (by special order,
bottom left).

**Maximum positive operating pressure**

Standard design: 5 bar

**Maximum positive operating pressure:**

High-pressure design
(supplementary charge): 8 bar

**Maximum operating temperature: 110 °C****Quality certificates****Strong brands of the highest quality**

VOGEL&NOOT offers its customers strong brands that meet highest quality standards. All the production sites' production processes are certified according to ISO. The quality and performance specifications of the convectors and heating panels have been verified by recognised European institutions.

The standards that the quality certificates require us to maintain give you security, the best heating performance and premium product quality. For the **VOGEL&NOOT** warranty conditions, please see the installation sheet, which is enclosed with each **VONARIS/KONTEC** convector or heating panel.



Horizontal design, VHV models

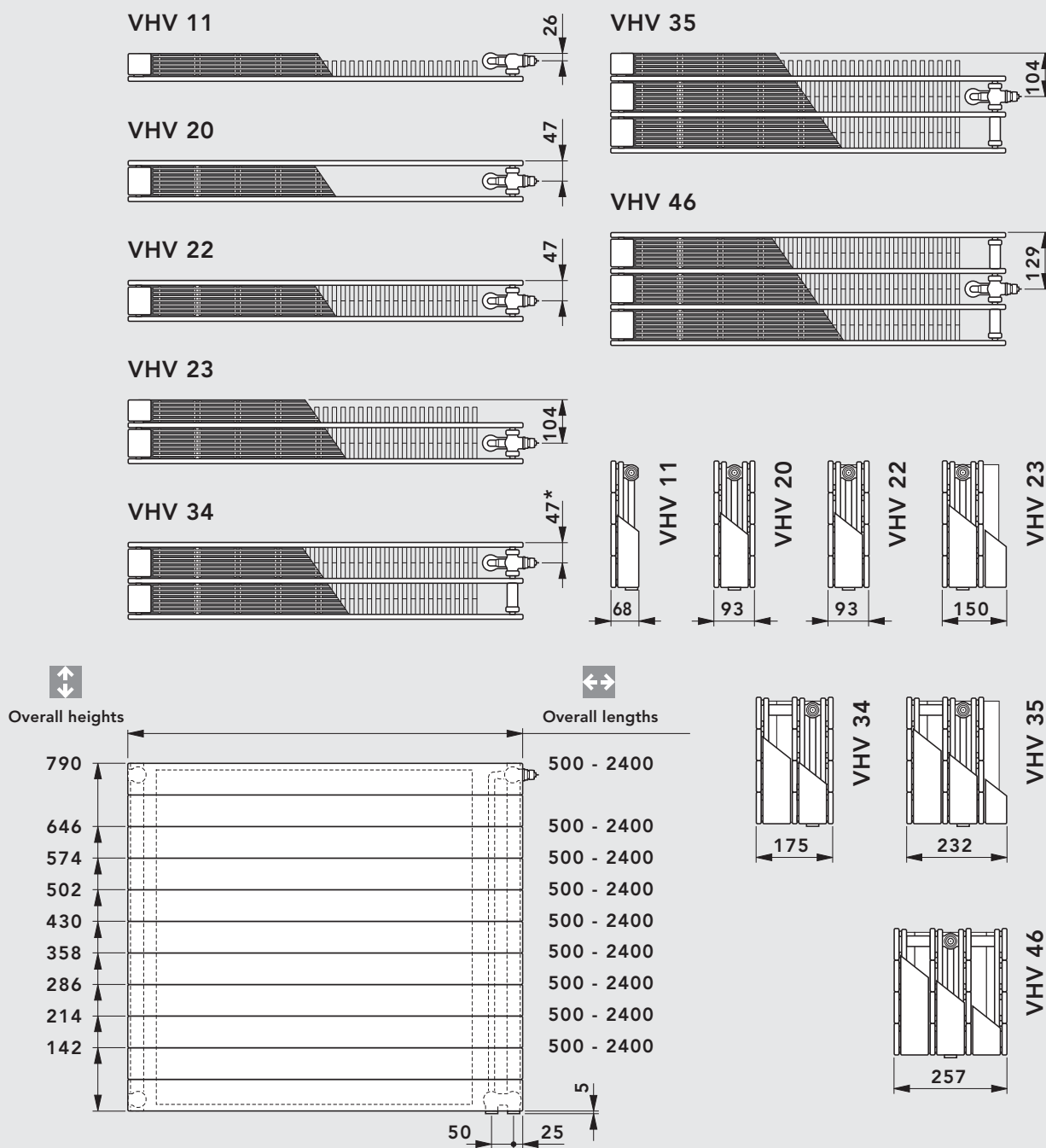

Schematic diagram

* Please note: If the VHV 34 model is turned and used as a left-hand design, the distance between the VONARIS rear panel and the connection point is 129 mm.

Model	VHV 11				VHV 20				VHV 22				VHV 23		VHV 34		VHV 35		VHV 46			
Overall height	214	286	358	430	142	214	286	358	430	142	214	286	358	430	142	214	142	214	142	214	142	214
Overall height [mm]	502	574	646	790	502	574	646	790	502	574	646	790	286		286		286		286			
Overall length	500 - 2400 mm (for special overall lengths see output tables)																					
Overall length [mm]																						
Increments	100 mm (for overall lengths of 1400 mm and above: 200 mm)																					

The VHV-S models

With their factory-welded heat reflector (no water-flow), the WVO designs return a major part of the otherwise lost heat to the room. They do so by means of convection between radiator and heat reflector.

Model overview / connection dimensions: horizontal design, VHV-S models

VHV-S 22

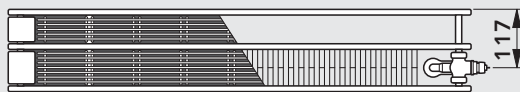

VHV-S 47

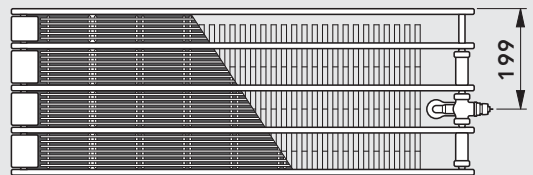

VHV-S 34

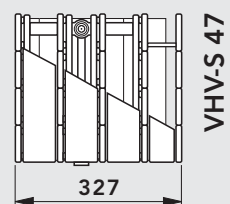
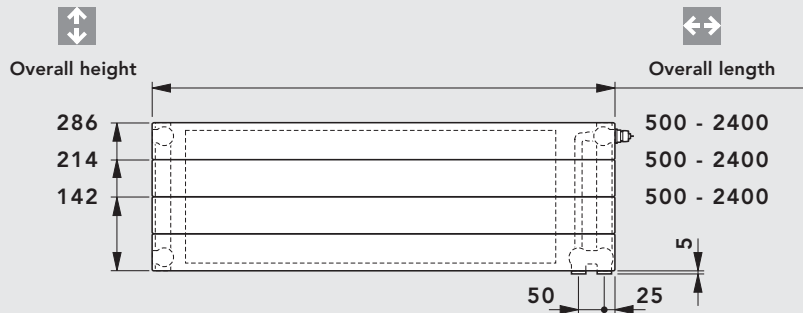
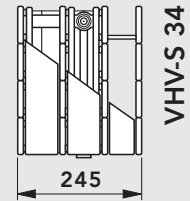
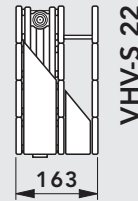
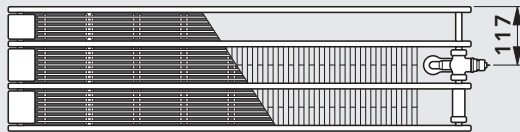

Schematic diagram

Model	VHV-S 22			VHV-S 34			VHV-S 47		
Overall height ↑ ↓ [mm]	142	214	286	142	214	286	142	214	286
Overall length ← → [mm]	500 - 2400 mm (for special overall lengths see output tables)								
Increments	100 mm (for overall lengths of 1400 mm and above: 200 mm)								

Vertical design, VSV models

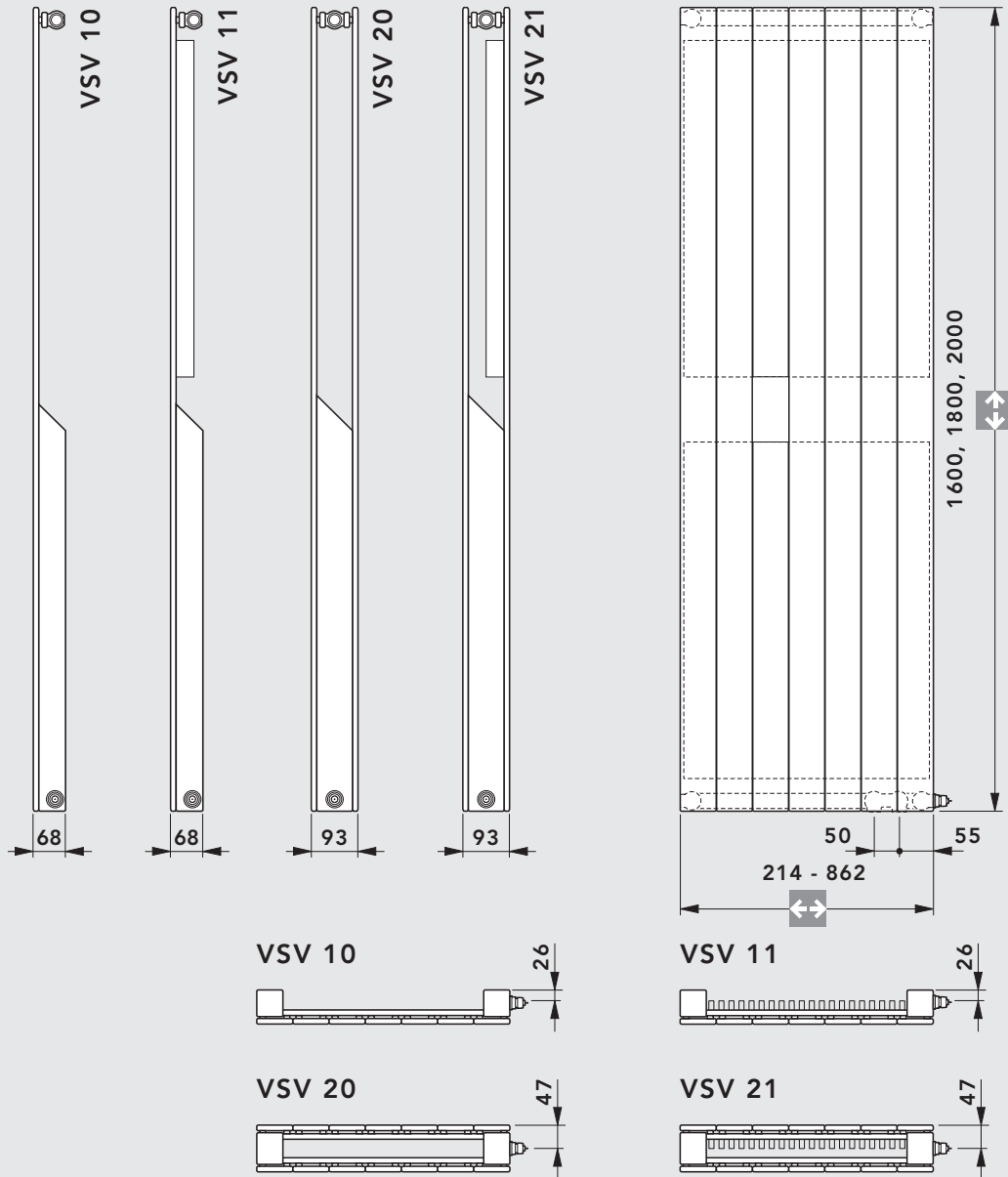

Schematic diagram

Model	VSV 10			VSV 11			VSV 20			VSV 21		
Overall height ↑↓ [mm]	1600	1800	2000	1600	1800	2000	1600	1800	2000	1600	1800	2000
Overall length ←→ [mm]	214 - 862 mm											
Increments	72 mm											

Horizontal design

Model description

VHV-S 34 / 286 / 2000

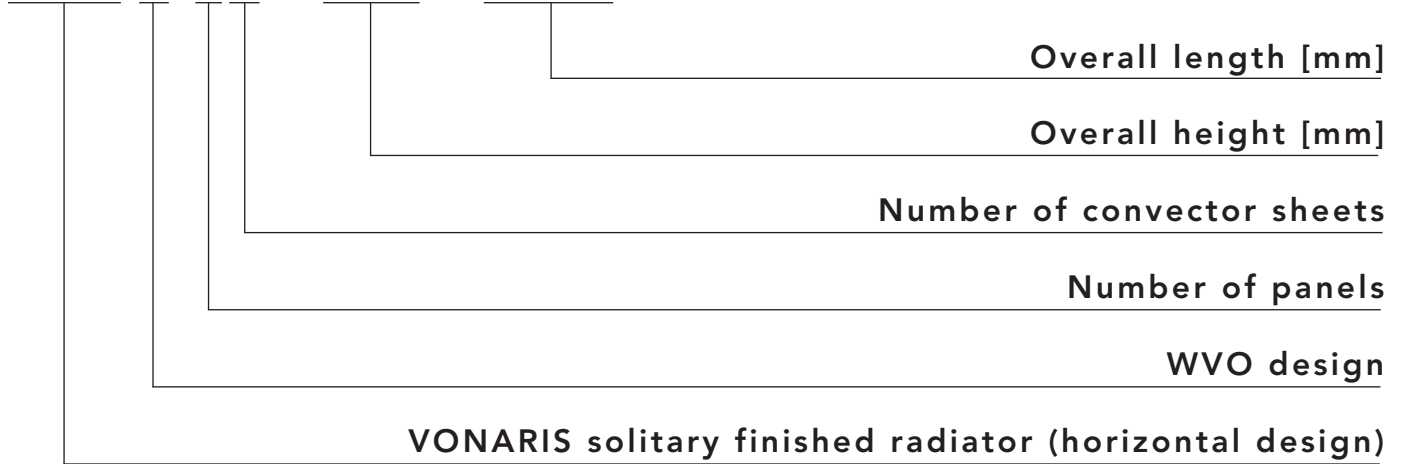

For each individual horizontal design order, the following data must be specified:

- Model (VHV, VHV-S)
- Overall height [mm]
- Overall length [mm]
- Specification of the RAL or Sanitary-Ware Colour number
- Connections for supply / return (by default at bottom right, by special order at bottom left; the VHV 20, VHV 22, VHV 34 and VHV 46 models can be connected either at bottom right or at bottom left)
- Positive operating pressure (N (normal) = standard design 5 bar / H (high) = high-pressure design 8 bar)
- Without brackets = 0 / with brackets = 1 (by default the VHV models will be delivered without brackets; exception: VHV 11 model: overall height between 358 and 790 mm, with brackets).

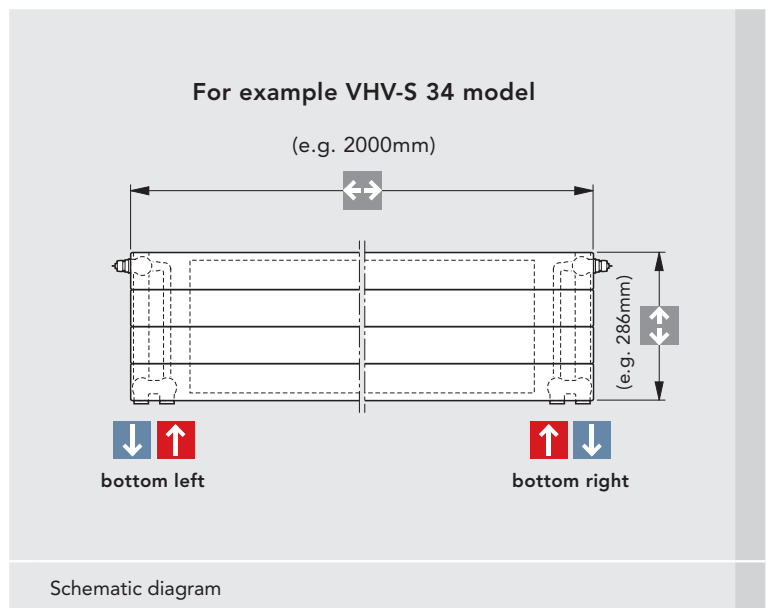

Order example:

1 item in horizontal design (WVO); connection bottom left; VHV-S 34 model; overall height 286 mm; overall length 2000 mm; colour RAL 3000; with 2 stand consoles SK 14 for use on finished floors; operating pressure 8 bar (high pressure design).

Example of an order form:

Pos./ Room	Num- ber	Model	Overall height [mm]	Overall length [mm]	Colour	Connections VSV	Connections VHV and VSV-S	Positive operating pressure	Brackets without = 0 with = 1	General accessories	
										Model	Number
-	1	VHV-S 34	286	2000	RAL 3000	bottom left	bottom left	H	0	SK 14	2

Vertical design

Model description

VSV 10 / 1600 / 574

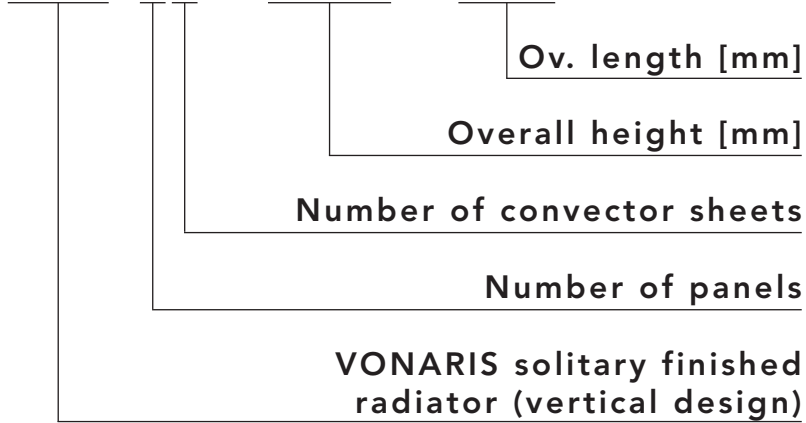

For each individual horizontal design order, the following data must be specified:

- Model (VSV)
- Overall height [mm]
- Overall length [mm]
- Specification of the RAL or Sanitary-Ware Colour number
- Connections for supply / return (by default at bottom right, by special order at bottom left)
- Positive operating pressure (N (normal) = standard design 5 bar / H (high) = high-pressure design 8 bar)
- By default the VSV models will be delivered with brackets

Please note:
The supply is always towards the outside in the vertical design.

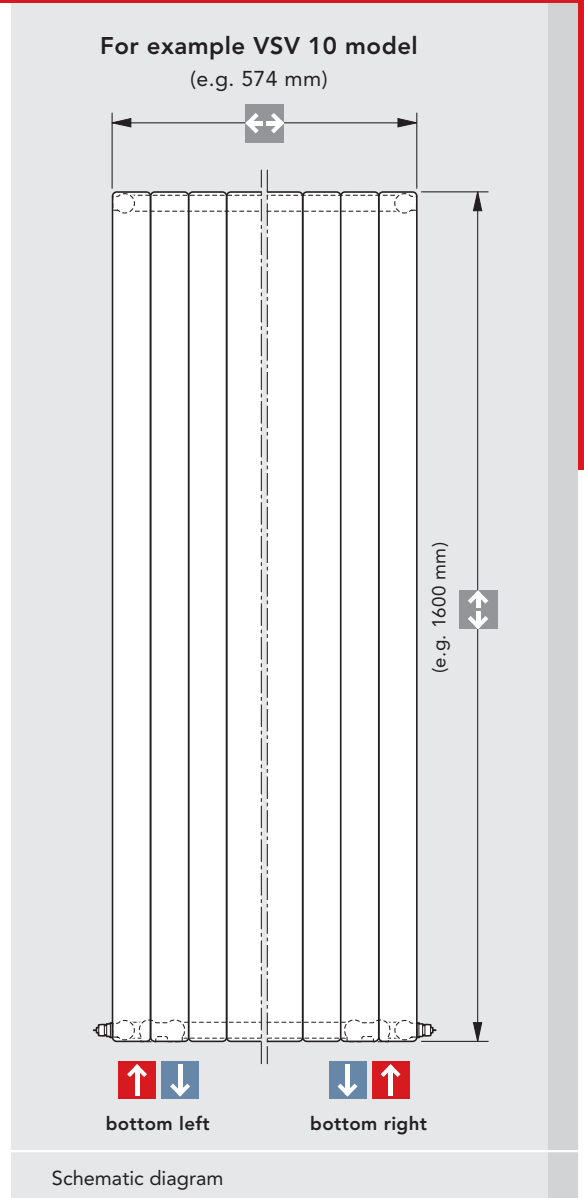

Order example:

1 item in vertical design; connection bottom left; VSV 10 model; overall height 1600 mm; overall length 574 mm; colour VNF 6904; with 2 wall suspension brackets WA 11; operating pressure 8 bar (high pressure design).

Example of an order form:

Pos./ Room	Number of items	Model	Overall height	Overall length	Colour	Connections VSV	Connections VHV and VSV-S	Positive operating pressure	Brackets without = 0 with = 1	General accessories	
			[mm]	[mm]						Model	Number
-	1	VSV 10	1600	574	VNF 6904	bottom left	bottom left	H	1	WA 11	2

Horizontal and vertical designs

It is easy to set the precise values required without using any special tools (see drawings).

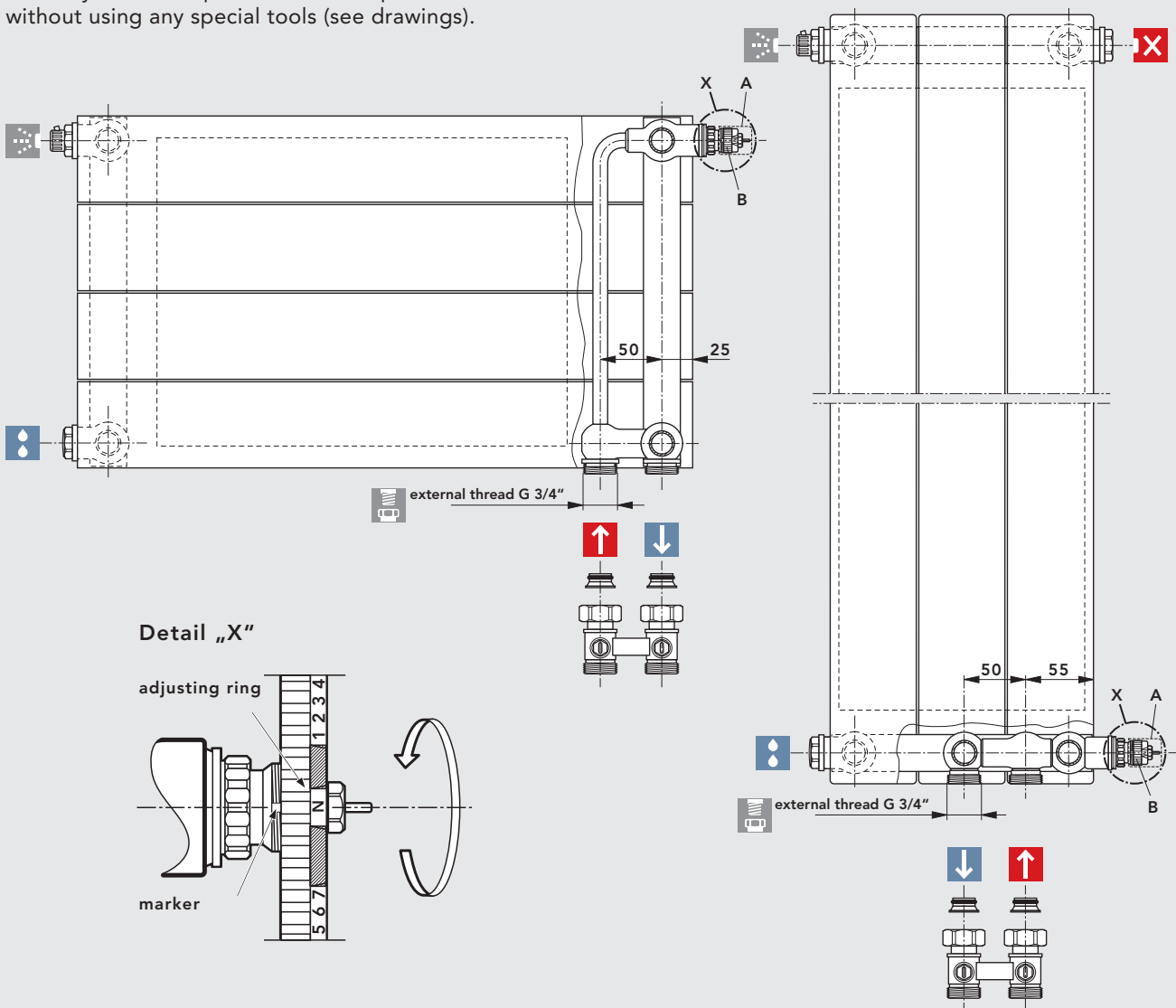

Schematic diagram

The radiator will be delivered with a fitted protective cap. After removing the protective cap (item A), the following thermostat heads can be installed directly onto the built-in valve (item B): „RA 2000“, or „RAW“ from Danfoss, „VK“ from Heimeier, „D“ from Herz, „thera DA“ from MNG, and „UNI XD“ from Oventrop.

Adjustment tips:

- Remove protective cap and sensor
- Lift the adjusting ring and turn it anti-clockwise, to the setting required – the set value (1, 2, ...7, N) needs to be directly in line with the marker.
- Presetting is possible in steps of 0.5 between 1 and 7. The „N“ setting, cancels all presetting.

Note: Settings in the hatched areas must be avoided.

Horizontal and vertical designs

Guideline values for default settings

Basis:
 Supply temperature **70 °C**
 Return temperature **55 °C**
 Room temperature **20 °C**

- Default setting **1** $k_v = 0.13$
For radiators up to about 500 W
- Default setting **2** $k_v = 0.21$
For radiators up to about 800 W
- Default setting **3** $k_v = 0.26$
For radiators up to about 1000 W
- Default setting **4** $k_v = 0.31$
For radiators up to about 1200 W
- Default setting **5** $k_v = 0.41$
For radiators up to about 1600 W
- Default setting **6** $k_v = 0.52$
For radiators up to about 2000 W
- Default setting **7** $k_v = 0.63$
For radiators up to about 2400 W
- Default setting **N** $k_v = 0.75$
For radiators of more than 2400 W

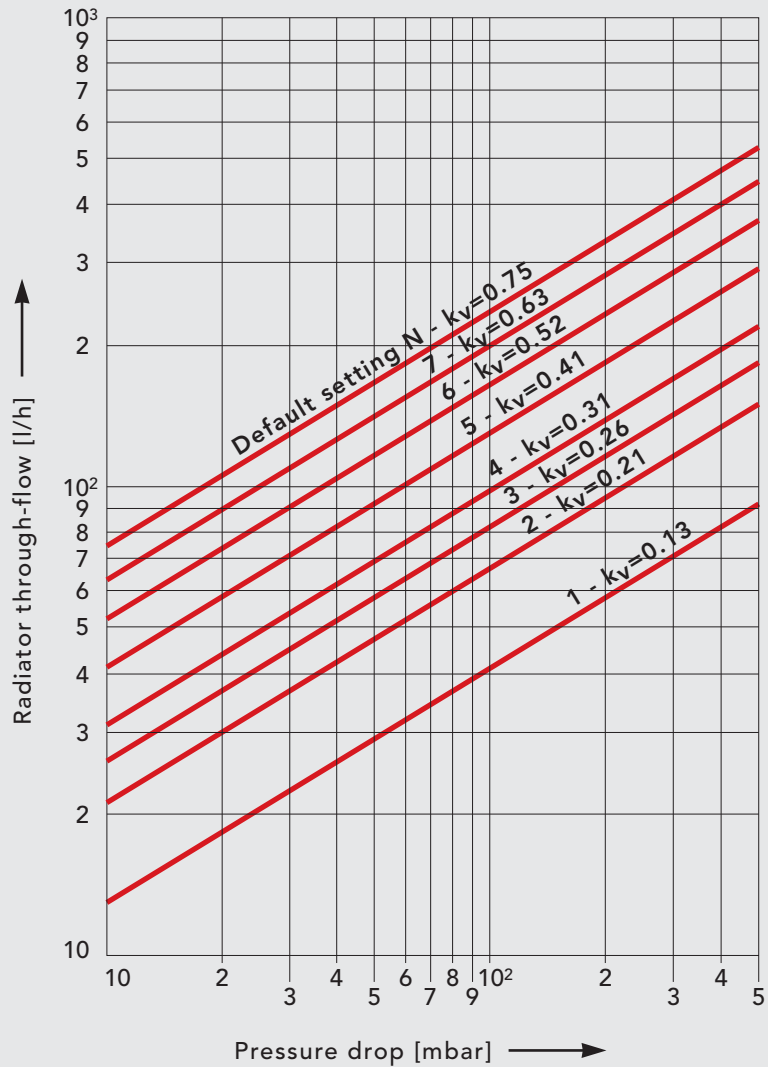

Chart 1:

Pressure drop [mbar] – double-pipe operation at 2K proportional offset.

It is of course possible to adjust the valve default setting, whilst there is pressure in the heating system.

Horizontal and vertical designs

A valve default setting is not necessary as the valve will be delivered factory-adjusted (default setting N).

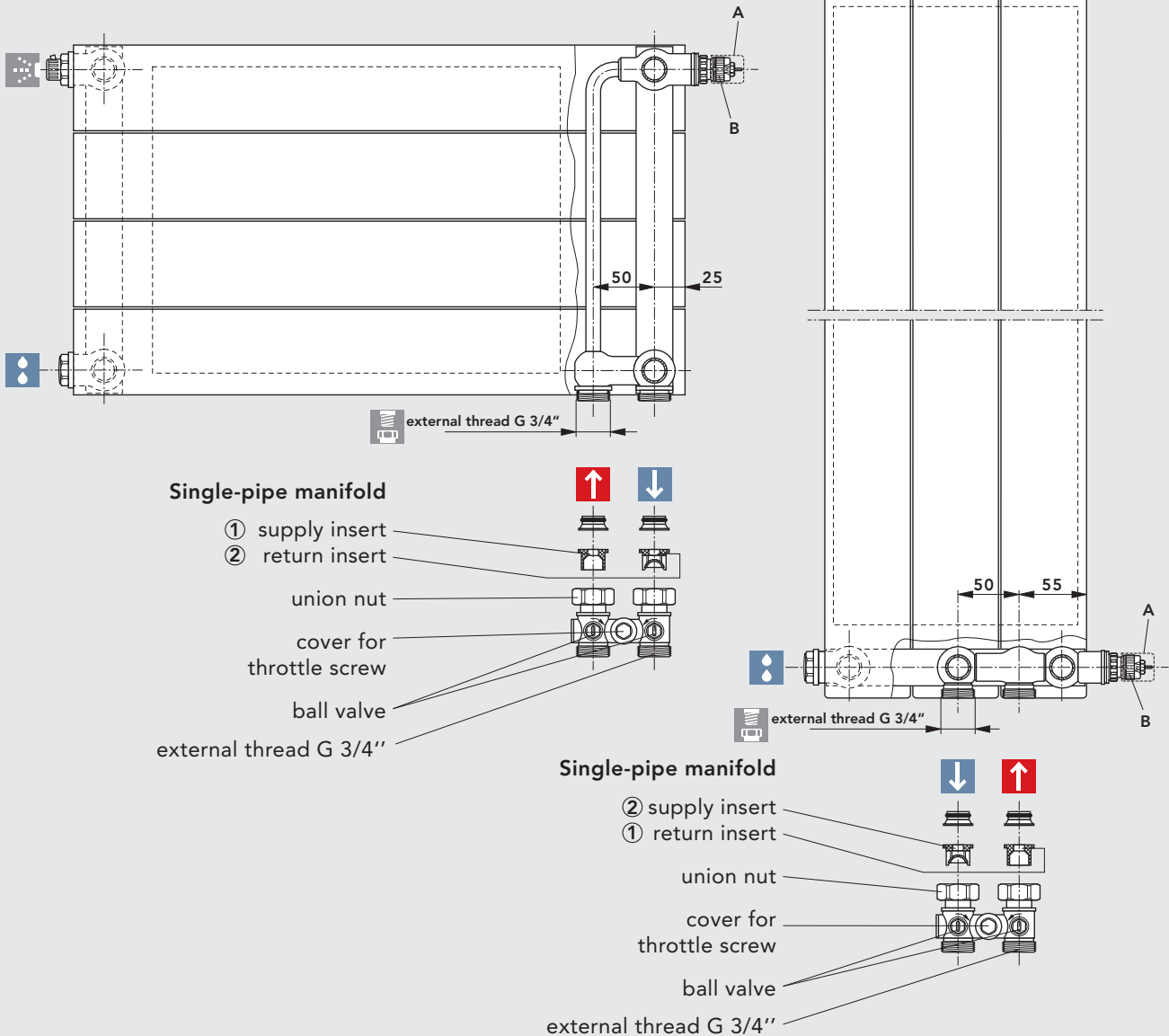

Schematic diagram

The radiator will be delivered with a fitted protective cap. After removing the protective cap (item A), the following thermostat heads can be installed directly onto the built-in valve (item B): „RA 2000“, or „RAW“ from Danfoss, „VK“ from Heimeier, „D“ from Herz, „thera DA“ from MNG, and „UNI XD“ from Oventrop.

Please note!

Horizontal design:

During the installation of the single-pipe manifold ensure that the return insert (②) is installed in the water return, and the supply insert (①) in the water supply.

Vertical design:

Prior to the installation of the one-pipe manifold it is essential to swap over the supply insert and the return insert so that the supply insert (①) is installed in the water supply, and the return insert (②) in the water return.

Horizontal and vertical designs

Default setting when using a single-pipe manifold:	radiator proportion 40% --- 2.50 revolutions *
radiator proportion 30% --- 3.50 revolutions *	radiator proportion 45% --- 2.00 revolutions *
radiator proportion 35% --- 3.00 revolutions *	radiator proportion 50% --- 1.75 revolutions *

*... before starting, turn the bypass spindle of the single-pipe manifold to the right as far as it will go.

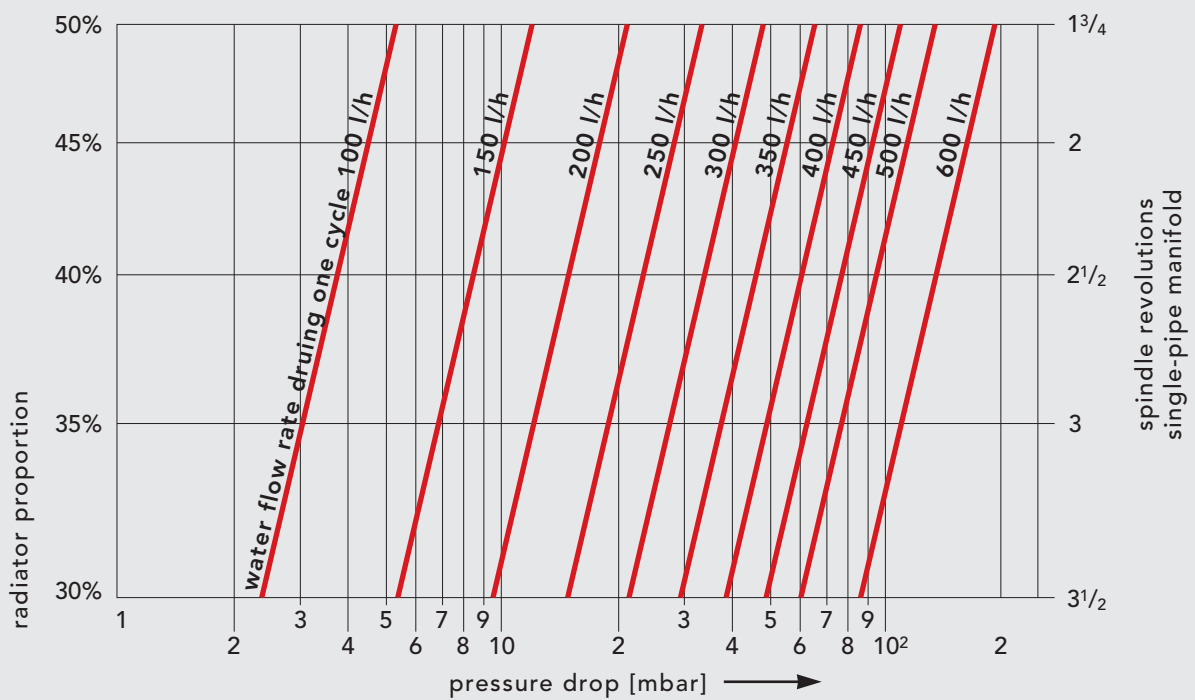

Chart 2:

Pressure drop [mbar] – single-pipe operation with a proportional deviation of 2K.
 It is of course possible to change the radiator proportion, whilst there is pressure in the heating system.

Please take account of the maximum power per cycle (for single-pipe installations) of about 10 kW:

$$\Delta T = T_1 - T_2 = 20 \text{ K (at } T_1 = 90 \text{ °C).}$$

VHV 20 and VHV 22 models, in horizontal design**The new heat reflector**

- is available for the VHV 20 model (OH 358 - 573 mm) and the VHV 22 model (OH 358 - 646 mm), in horizontal design
- returns a major part of the otherwise lost heat to the room, by means of convection between the VONARIS solitary finished radiator and the heat reflector.

Design:

Electrophoretically coated and finish in RAL 9016 (on request and at an extra charge, available in a range of RAL and Sanitary Ware colours); delivered with 8 push-in brackets, 8 stabilising brackets, 4 Z-brackets, an installation sheet, and packaging

Note:

When ordering a horizontal design with heat reflector, it is essential to use the SK 22(VHV 20) or SK 23 (VHV 22) stand consoles.

VONARIS solitary finished radiators with a fitted heat reflector (see diagram right)

- Depth: 11 mm heat reflector
- Internal depth: 25 mm between heating pipe and heat reflector
- Minimum clearance*:100 mm** between window surface and heat reflector

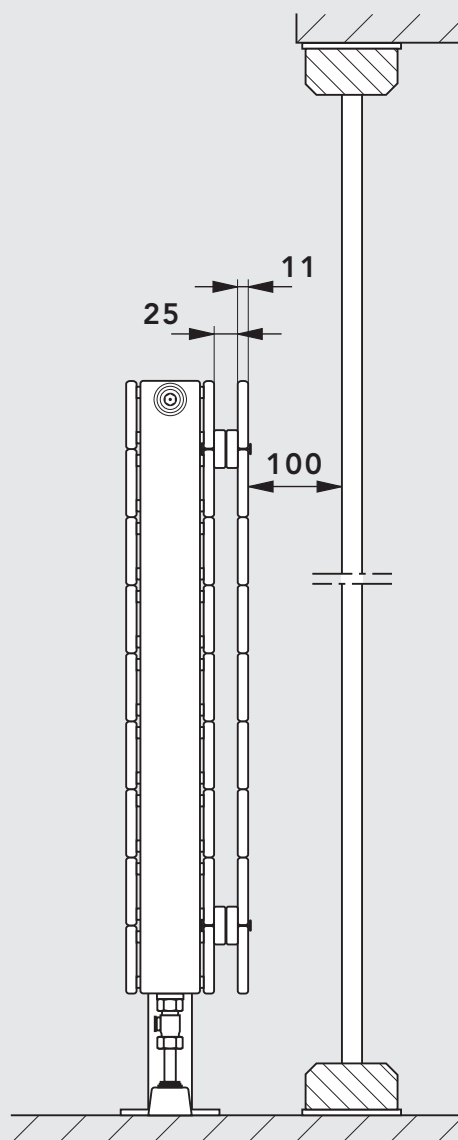

Schematic diagram

VONOMAT wall console for the VHV 11 and VHV 23 models

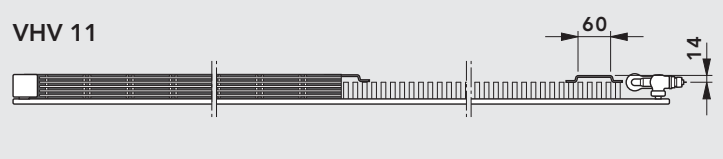
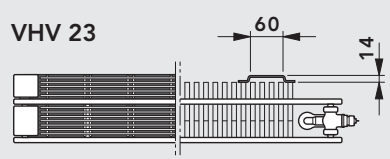
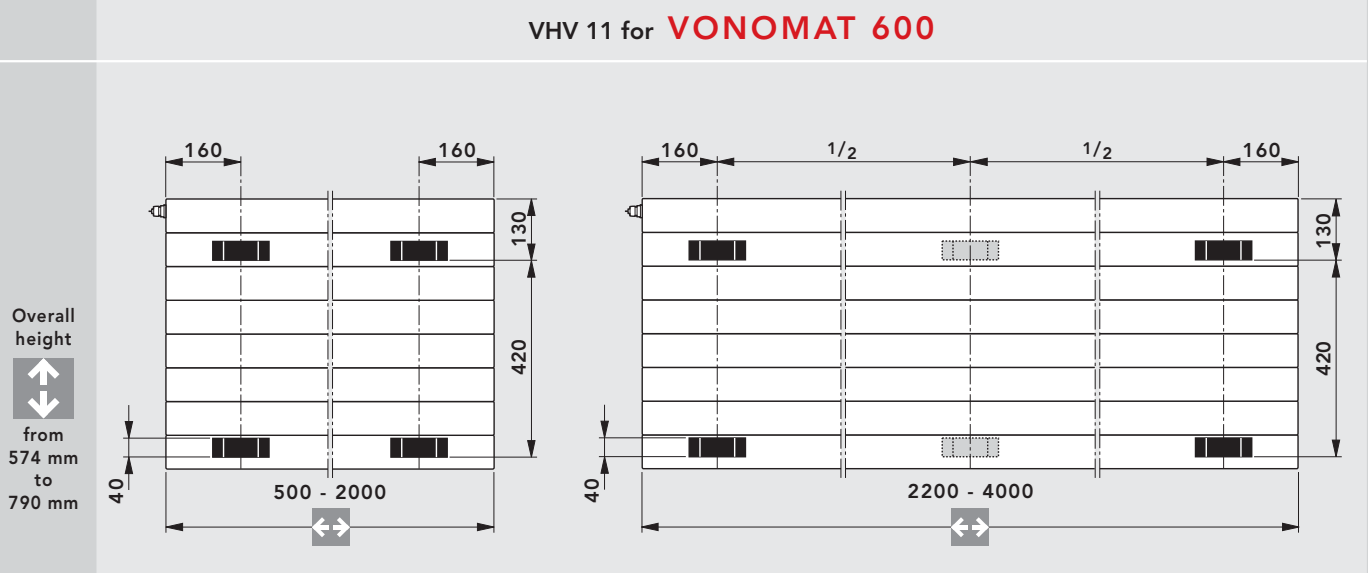
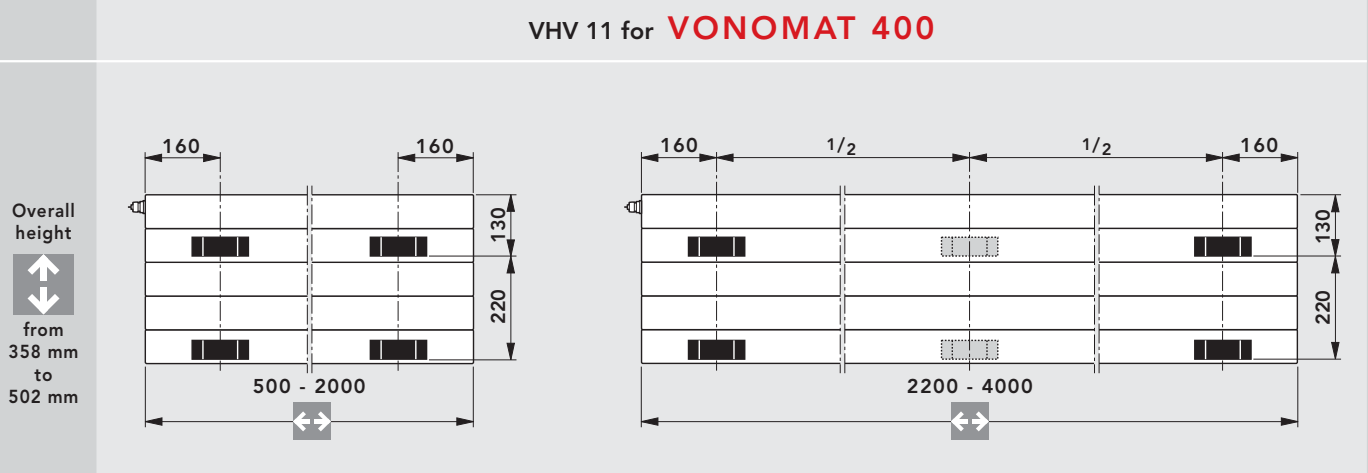
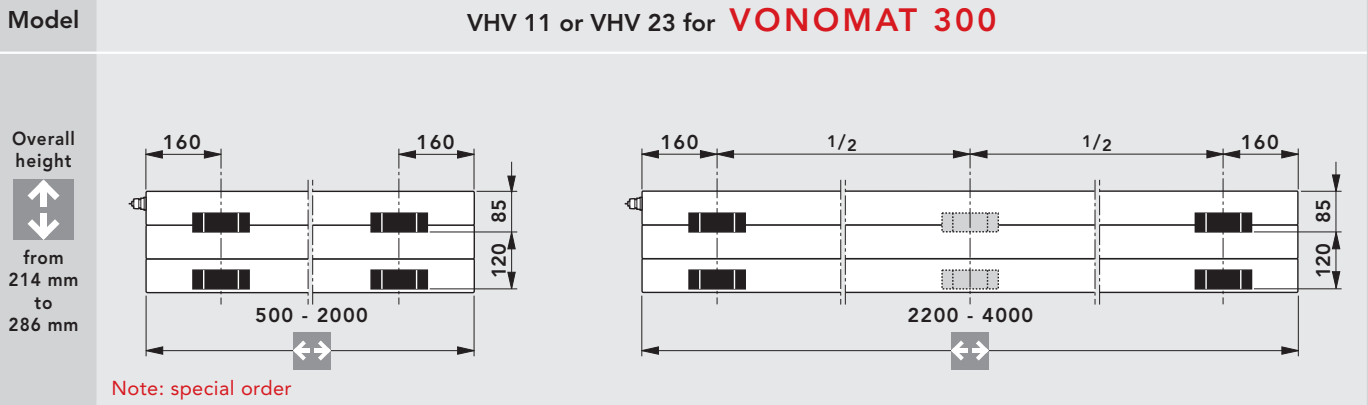

Schematic diagram

Note: for the horizontal design, brackets will be delivered as standard only with the VHV 11 (OH 358 – 790 mm) model. If a VONOMAT wall console is used with the VHV 11 (OH 214 – 286 mm) and the VHV 23 (214 – 286) models, they must be ordered as a special design with brackets.

VONOMAT wall console for the VHV 11 and VHV 23 models

The VONARIS solitary finished radiator can be installed easily, quickly and securely, whilst it is still in its wrapper. This is made possible by the VONOMAT wall console for the horizontal designs of VHV 11 (OH 214 – 790 mm) and VHV 23 (OH 214 and 286 mm) with fitted brackets.

Wall rails for OH 214 – 790 mm

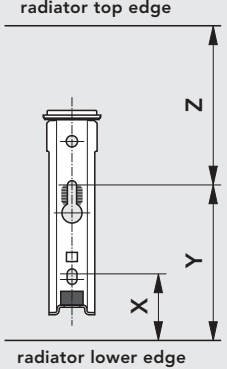
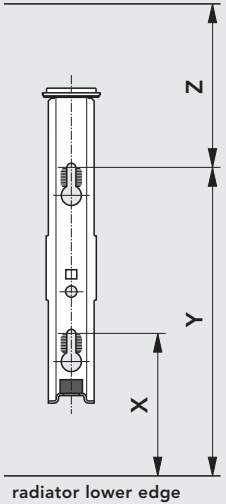
Drilling measurements for the VONOMAT 300 – 600					
Wall rail for OH 214 / 286 mm	Overall radiator height [mm] 	Value X [mm]	Value Y [mm]	Value Z [mm]	Wall rail for OH 358 – 790 mm
	214	34	114	100	
	286	61	141	145	
	358	58	209	149	
	430	130	281	149	
	502	202	353	149	
	574	74	425	149	
	646	146	497	149	
	790	290	641	149	



Schematic diagram

The VONOMAT wall console with integrated connection and displacement locking features consists of:

- 2 or *3 consoles with sound-proofing,
- 2 or *3 snap-on elements,
- 2 or *3 mounting screws with dowels and safety washers

*For overall lengths of 2200 mm and greater

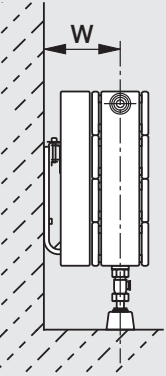
Connection – wall clearance

	Horizontal design model	Overall height [mm] 	Measurement W [mm]
	VHV 11	214 - 790	43
	VHV 23	214 - 286	121,5

The VONOMAT wall console complies with the requirements of the TÜV Rheinland (for physical load-bearing purposes).

Schematic diagram

VONOFIX rapid-installation console for the VHV models

VHV 20 and 22 models: OH 214 – 790 mm, VHV 34 model: OH 214 and 286 mm

OH 214: for the **VONOFIX 1**

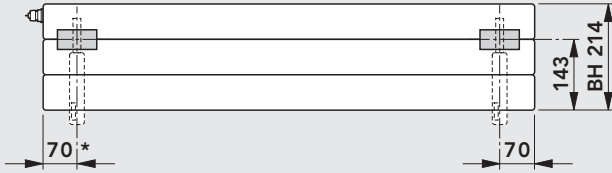

OH 574 and 646: for the **VONOFIX 4**

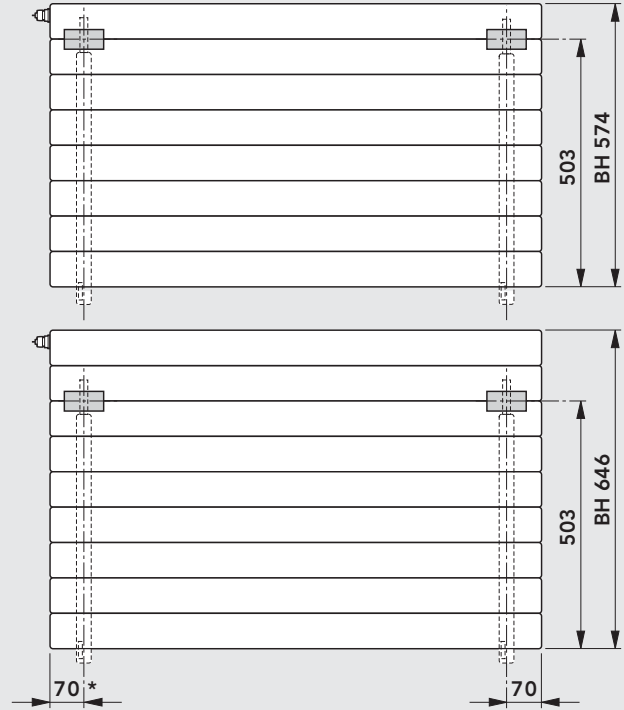

BH 286 and 358: for the **VONOFIX 2**

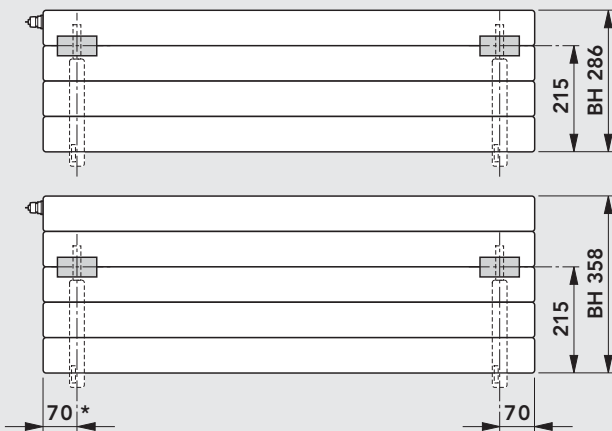

OH 430 and 502: for the **VONOFIX 3**

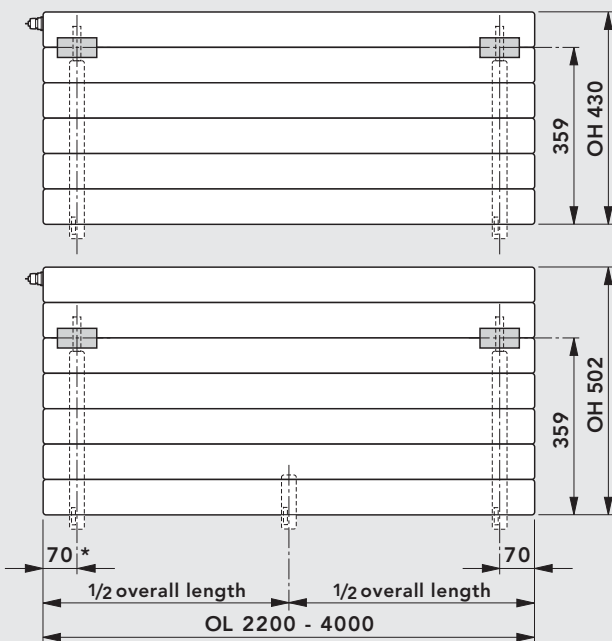

OH 790: for the **VONOFIX 5**

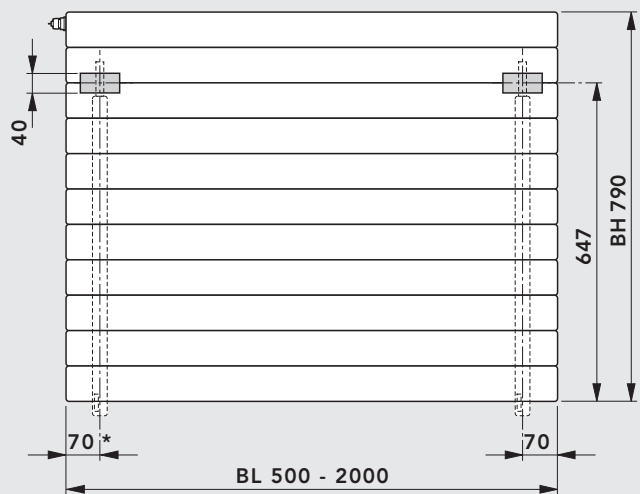

Note: for an overall length of 2200 mm and greater an additional piece of foot console must be used!

Schematic diagram

Important: the installation of VHV models with insertion (push-in) brackets is only feasible when using the **VONOFIX** rapid-installation console!

*If you are using a right-angled valve block to connect your VHV models, please leave clearance of **110 mm**, instead of **70 mm**, from the radiator's outside edge for the installation of **VONOFIX**.

VONOFIX rapid-installation console for the VHV models

The VONARIS solitary finished radiator can be installed easily, quickly and securely. This is made possible by the VONOFIX rapid-installation console for the horizontal designs of the VHV 20, VHV 22 (OH 214 – 790 mm) and VHV 34 (OH 214 and 286 mm) models.

Wall rails for OH 214 – 790 mm

Drilling measurements for the VONOFIX 1 - 5

	Overall radiator height [mm]	Value X [mm]	Value Y [mm]	Value Z [mm]
	214	–	125	89
	286	100	197	89
	358	100	197	161
	430	100	341	161
	502	100	341	161
	574	100	485	89
	646	100	485	89
	790	100	629	161

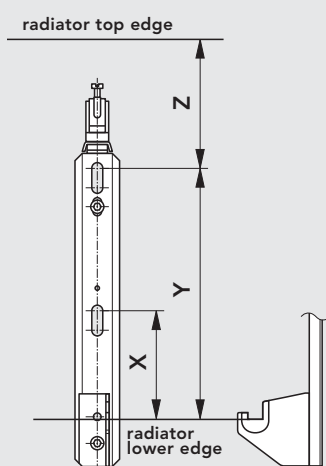

Schematic diagram

The VONOFIX rapid-installation console consists of:

- 2 wall consoles (zinc-plated), with sound-proofing filters, screws and dowels
- 2 stabilising brackets
- 2 insertion (push-in) brackets
- (For an overall length of 2200 mm and greater, 1 additional piece of foot console)

Connection – wall clearance

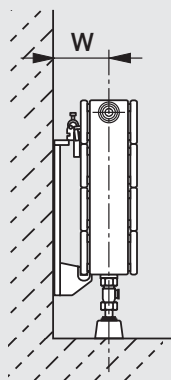

Horizontal design model	Overall height [mm]	Measurement W [mm]
VHV 20	358 – 790	91
VHV 22	214 – 790	91
VHV 34	214 – 286	91*

***Note:** if the VHV 34 is turned round and used as a left-hand design model, the measurement W is 172 mm.

Schematic diagram

VSV models

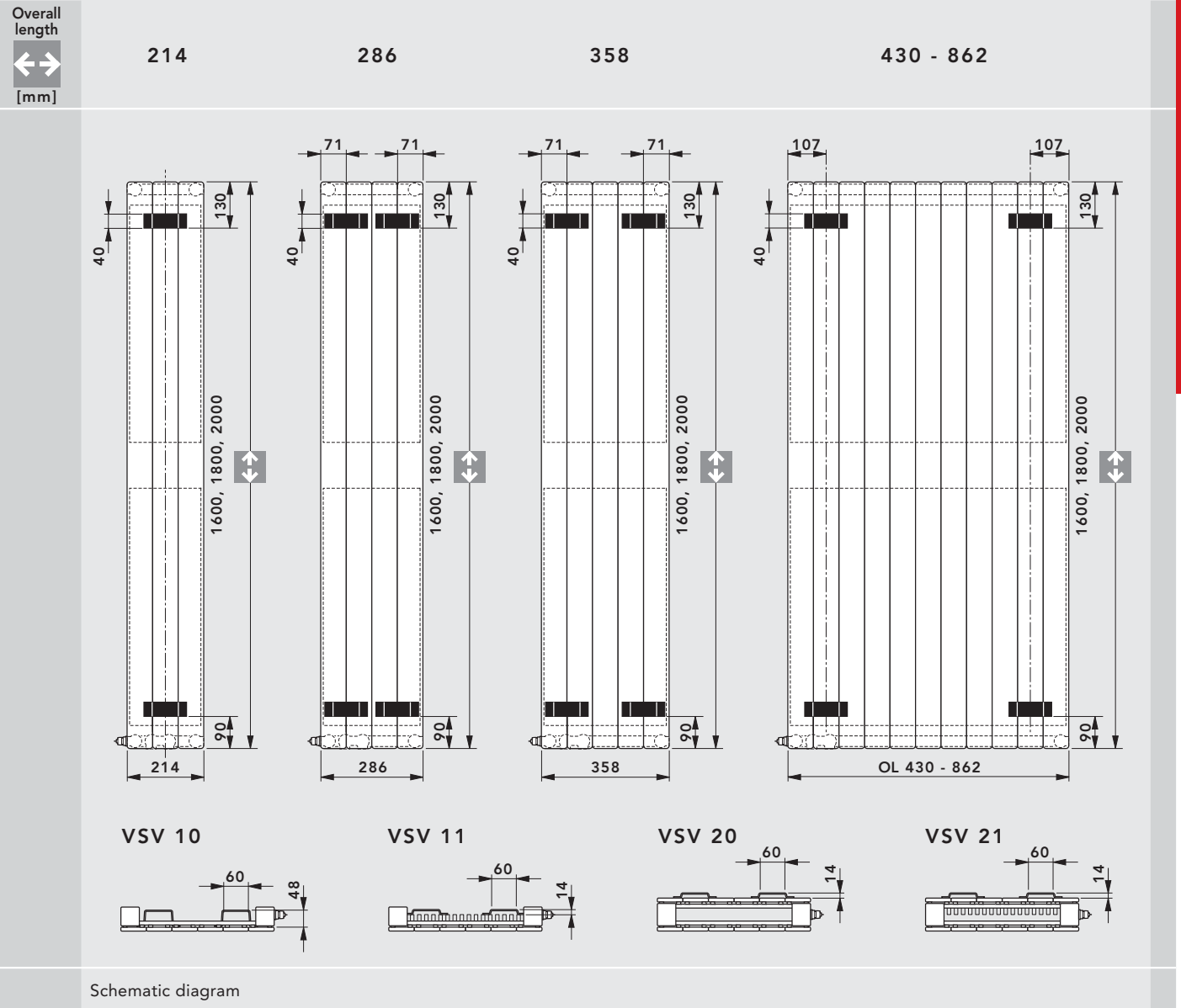

Wall clearance measurements: WA 10 and WA 11 wall mounting brackets for the VSV models

Connection – wall clearance

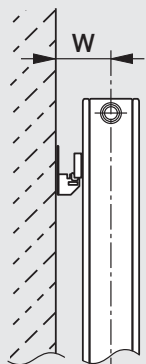

Wall mounting brackets model	Vertical design model	Measurement W [mm]
WA 10	VSV 10/11*	35
WA 10	VSV 20/21	79,5
WA 11	VSV 10/11*	45
WA 11	VSV 20/21	89,5

***Note:** if you are installing the VSV 10 or VSV 11 models with a right-angled-design connection, please use the appropriate drilling consoles or angle-fish-plate mounting brackets, to achieve the required wall clearance.

Schematic diagram

Wall consoles WK 10 – 12: positioning for VHV models (up to an overall height of 286 mm)

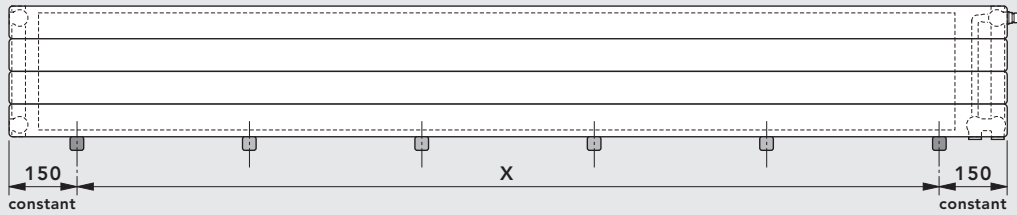

Note: when using more than 2 wall consoles the additional wall consoles must be placed at regular intervals along the line X.

WK 10 wall console

VHV 11

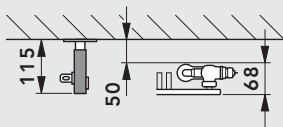

VHV 20

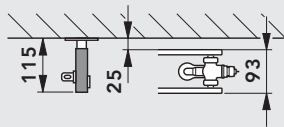

VHV 22

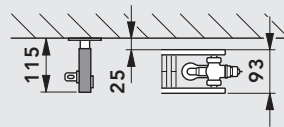

WK 11 wall console

VHV 23

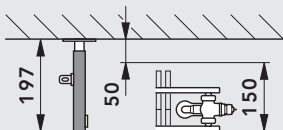

VHV 34

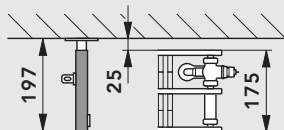

WK 12 wall console

VHV 35

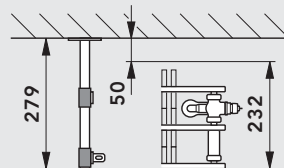

VHV 46

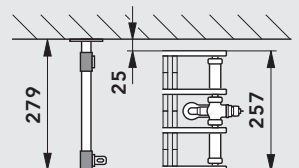

Schematic diagram

Stand consoles SK 22 and SK 23: positioning for VHV models (for an overall height of 358 mm and greater)

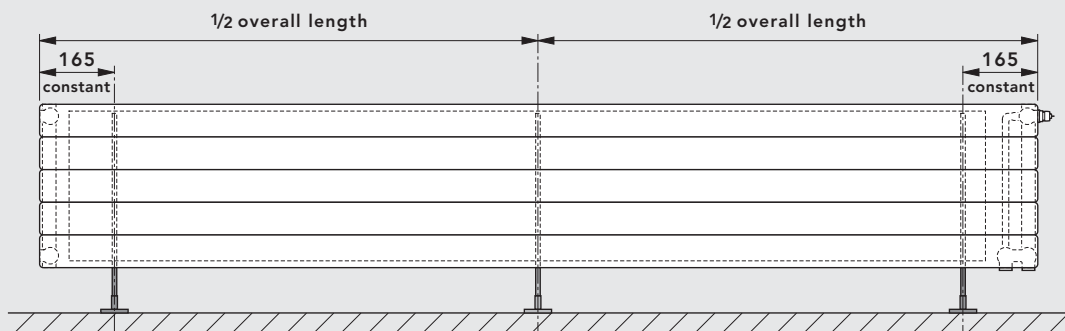

Note: for an overall length of 2200 mm and greater, a 3rd stand console must be used!

Schematic diagram

Stand consoles SK 10 – 19: positioning for the VHV/VHV-S models (up to an overall height of 286 mm)

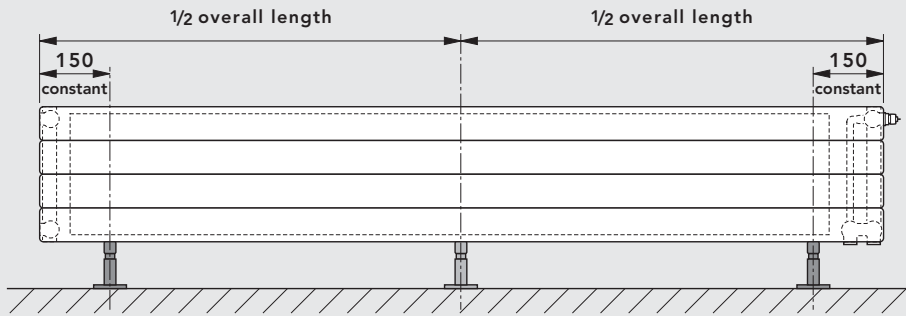

Note: for an overall length of 2200 mm and greater, a 3rd stand console must be used!

SK 10 / SK 11

VHV 11

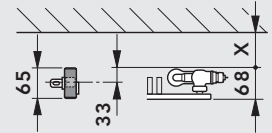

SK 12 / SK 13

VHV 20

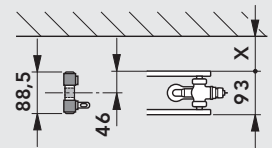

SK 12 / SK 13

VHV 22

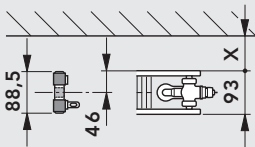

VHV 23

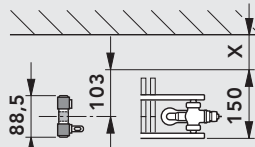

SK 14 / SK 15

VHV-S 22

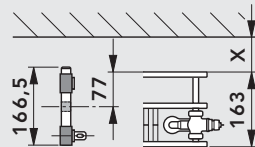

VHV 34

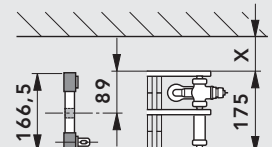

SK 14 / SK 15

VHV 35

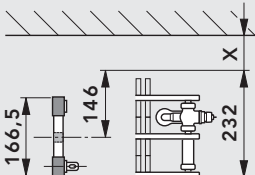

VHV-S 34

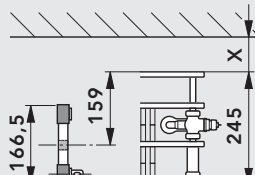

SK 16 / SK 17

VHV 46

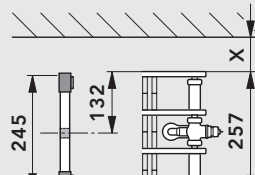

SK 18 / SK 19

VHV-S 47

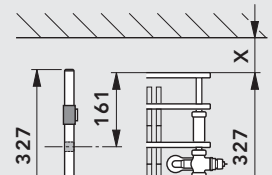

Schematic diagram

Window sill support FBT 20: positioning for the VHV/VHV-S models (up to an overall height of 286 mm)

Window sill support for subsequent installation with the VHV/VHV-S 22-47 models of the VONARIS solitary finished radiator (up to an overall height of 286 mm)

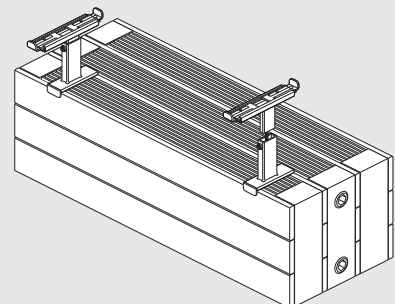
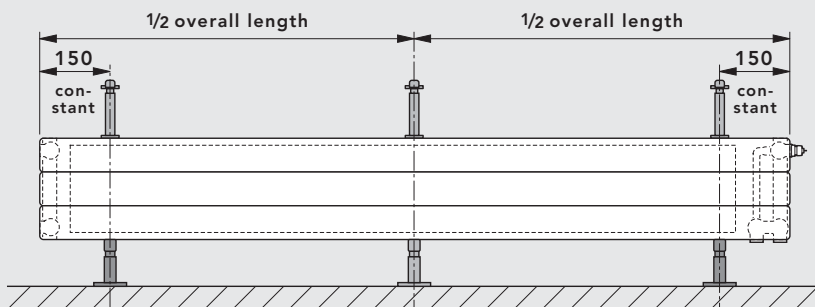

Note: for an overall length of 2200 mm and greater, a 3rd stand console must be used!

Schematic diagram

Heating output in compliance with DIN EN 442, and ÖNORM EN 442, at 75/65/20° C

Side panels and top cover are included in the heat output specifications



Overall depth
68 mm

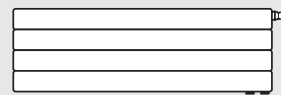
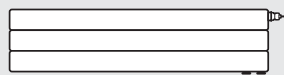

Overall height
[mm]

214

286

Model

VHV 11

VHV 11



Overall length
[mm]

Output
[Watts]

Output
[Watts]

500

232

289

600

278

346

700

325

404

800

371

462

900

418

519

1000

464

577

1100

510

635

1200

557

692

1300

603

750

1400

650

808

1600

742

923

1800

835

1039

2000

928

1154

2200

1021

1269

2400

1114

1385

2600

1206

1500

2800

1299

1616

3000

1392

1731

3200

1485

1846

3400

1578

1962

3600

1670

2077

3800

1763

2193

4000

1856

2308

Watts/m 70/55/20

374

464

Watts/m 55/45/20

236

291

Water content l/m

1,67

2,22

Weight kg/m

11,14

14,51

Radiator exponent n

1,32

1,34

Heating output in compliance with DIN EN 442, and ÖNORM EN 442, at 75/65/20° C

Side panels and top cover are included in the heat output specifications



Overall depth
68 mm

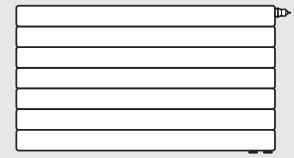
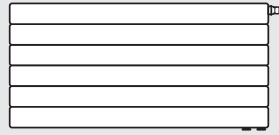
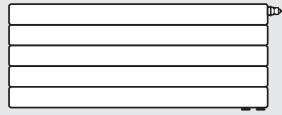

Overall height
[mm]

358

430

502

Model

VHV 11

VHV 11

VHV 11



Overall length
[mm]

Output
[Watts]

Output
[Watts]

Output
[Watts]

500

334

380

423

600

400

456

507

700

467

532

592

800

534

608

676

900

600

684

761

1000

667

760

845

1100

734

836

930

1200

800

912

1014

1300

867

988

1099

1400

934

1064

1183

1600

1067

1216

1352

1800

1201

1368

1521

2000

1334

1520

1690

2200

1467

1672

1859

2400

1601

1824

2028

2600

1734

1976

2197

2800

1868

2128

2366

3000

2001

2280

2535

3200

2134

2432

2704

3400

2268

2584

2873

3600

2401

2736

3042

3800

2535

2888

3211

4000

2668

3040

3380

Watts/m 70/55/20

540

615

683

Watts/m 55/45/20

344

391

433

Water content l/m

2,78

3,33

3,87

Weight kg/m

16,71

19,85

22,99

Radiator exponent n



1,30

1,30

1,31

Heating output in compliance with DIN EN 442, and ÖNORM EN 442, at 75/65/20° C

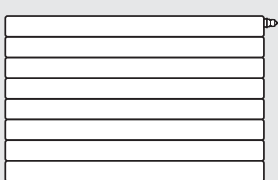
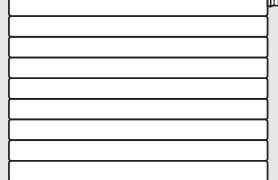
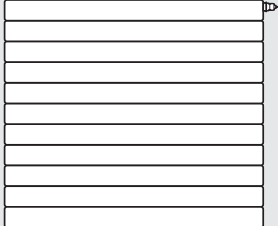
Side panels and top cover are included in the heat output specifications

									
Overall depth 68 mm									
	574			646			790		
Model	VHV 11			VHV 11			VHV 11		
	Overall length [mm]	Output [Watts]	Output [Watts]	Output [Watts]	Output [Watts]	Output [Watts]	Output [Watts]	Output [Watts]	
500		461		495		553			
600		553		593		663			
700		645		692		774			
800		737		791		884			
900		829		890		995			
1000		921		989		1105			
1100		1013		1088		1216			
1200		1105		1187		1326			
1300		1197		1286		1437			
1400		1289		1385		1547			
1600		1474		1582		1768			
1800		1658		1780		1989			
2000		1842		1978		2210			
2200		2026		2176		2431			
2400		2210		2374		2652			
2600		2395		2571		2873			
2800		2579		2769		3094			
3000		2763		2967		3315			
3200		2947		3165					
3400		3131		3363					
3600		3316		3560					
3800		3500		3758					
4000		3684		3956					
Watts/m 70/55/20		743		797		889			
Watts/m 55/45/20		470		503		558			
Water content l/m		4,44		4,99		6,12			
Weight kg/m		26,15		29,29		33,55			
Radiator exponent n		1,32		1,32		1,34			

Heating output in compliance with DIN EN 442, and ÖNORM EN 442, at 75/65/20° C

Side panels and top cover are included in the heat output specifications



Overall depth
93 mm

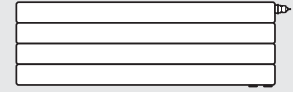
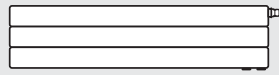
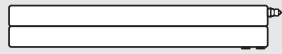

Overall height
[mm]

142

214

286

Model

VHV 20

VHV 20

VHV 20



Overall length
[mm]

Output
[Watts]

Output
[Watts]

Output
[Watts]

500

152

220

281

600

182

264

337

700

213

308

393

800

243

352

449

900

274

396

505

1000

304

440

561

1100

334

484

617

1200

365

528

673

1300

395

572

729

1400

426

616

785

1600

486

704

898

1800

547

792

1010

2000

608

880

1122

2200

669

968

1234

2400

730

1056

1346

2600

790

1144

1459

2800

851

1232

1571

3000

912

1320

1683

3200

973

1408

1795

3400

1034

1496

1907

3600

1094

1584

2020

3800

1155

1672

2132

4000

1216

1760

2244

Watts/m 70/55/20

249

359

458

Watts/m 55/45/20

161

232

296

Water content l/m

2,18

3,34

4,44

Weight kg/m

9,26

13,27

17,28

Radiator exponent n







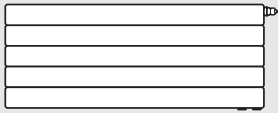

1,24

1,25

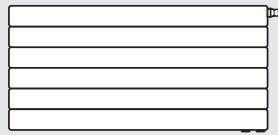
1,25

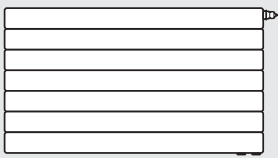
Heating output in compliance with DIN EN 442, and ÖNORM EN 442, at 75/65/20° C

Side panels and top cover are included in the heat output specifications

 Overall depth 93 mm	 	 	 
 Overall height [mm]	358	430	502
Model	VHV 20	VHV 20	VHV 20
 Overall length [mm]	Output [Watts]	Output [Watts]	Output [Watts]
500	327	379	430
600	392	454	515
700	458	530	601
800	523	606	687
900	589	681	773
1000	654	757	859
1100	719	833	945
1200	785	908	1031
1300	850	984	1117
1400	916	1060	1203
1600	1046	1211	1374
1800	1177	1363	1546
2000	1308	1514	1718
2200	1439	1665	1890
2400	1570	1817	2062
2600	1700	1968	2233
2800	1831	2120	2405
3000	1962	2271	2577
3200	2093	2422	2749
3400	2224	2574	2921
3600	2354	2725	3092
3800	2485	2877	3264
4000	2616	3028	3436
Watts/m 70/55/20	533	617	699
Watts/m 55/45/20	344	398	449
Water content l/m	5,55	6,66	7,77
Weight kg/m	21,29	25,30	29,31
Radiator exponent n	1,26	1,26	1,27

Heating output in compliance with DIN EN 442, and ÖNORM EN 442, at 75/65/20° C

Side panels and top cover are included in the heat output specifications



Overall depth
93 mm

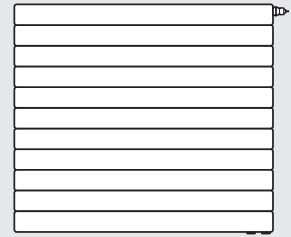
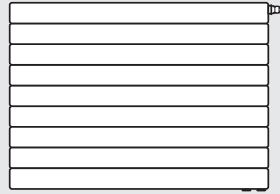
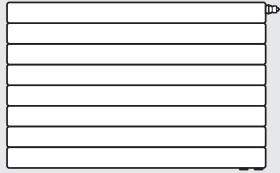

Overall height
[mm]

574

646

790

Model

VHV 20

VHV 20

VHV 20



Overall length
[mm]

Output
[Watts]

Output
[Watts]

Output
[Watts]

500

480

532

636

600

576

638

763

700

672

744

890

800

768

850

1017

900

864

957

1144

1000

960

1063

1271

1100

1056

1169

1398

1200

1152

1276

1525

1300

1248

1382

1652

1400

1344

1488

1779

1600

1536

1701

2034

1800

1728

1913

2288

2000

1920

2126

2542

2200

2112

2339

2796

2400

2304

2551

3050

2600

2496

2764

3305

2800

2688

2976

3559

3000

2880

3189

3813

3200

3072

3402

3400

3264

3614

3600

3456

3827

3800

3648

4039

4000

3840

4252

Watts/m 70/55/20

781

863

1032

Watts/m 55/45/20

502

553

661

Water content l/m

8,88

9,99

12,22

Weight kg/m

33,31

37,32

45,33

Radiator exponent n







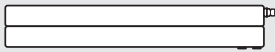

1,27

1,28

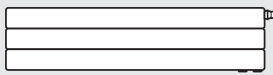
1,28

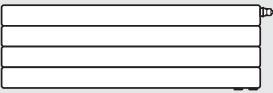
Heating output in compliance with DIN EN 442, and ÖNORM EN 442, at 75/65/20° C

Side panels and top cover are included in the heat output specifications

	Side panels and top cover are included in the heat output specifications			
Overall depth 93 mm	 	 	 	
	Overall height [mm]	142	214	286
Model	VHV 22	VHV 22	VHV 22	
	Overall length [mm]	Output [Watts]	Output [Watts]	Output [Watts]
500	321	419	516	
600	385	503	619	
700	449	587	722	
800	513	670	826	
900	577	754	929	
1000	641	838	1032	
1100	705	922	1135	
1200	769	1006	1238	
1300	833	1089	1342	
1400	897	1173	1445	
1600	1026	1341	1651	
1800	1154	1508	1858	
2000	1282	1676	2064	
2200	1410	1844	2270	
2400	1538	2011	2477	
2600	1667	2179	2683	
2800	1795	2346	2890	
3000	1923	2514	3096	
3200	2051	2682	3302	
3400	2179	2849	3509	
3600	2308	3017	3715	
3800	2436	3184	3922	
4000	2564	3352	4128	
Watts/m 70/55/20	519	674	825	
Watts/m 55/45/20	330	423	510	
Water content l/m	2,18	3,34	4,44	
Weight kg/m	13,97	20,59	27,23	
Radiator exponent n	1,30	1,34	1,38	

Heating output in compliance with DIN EN 442, and ÖNORM EN 442, at 75/65/20° C

Side panels and top cover are included in the heat output specifications



Overall depth
93 mm

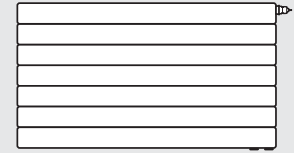
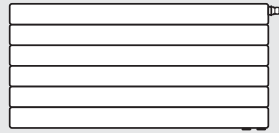
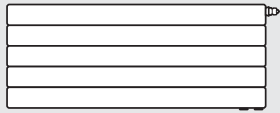

Overall height
[mm]

358

430

502

Model

VHV 22

VHV 22

VHV 22



Overall length
[mm]

Output
[Watts]

Output
[Watts]

Output
[Watts]

500

599

672

737

600

718

806

884

700

838

940

1032

800

958

1074

1179

900

1077

1209

1327

1000

1197

1343

1474

1100

1317

1477

1621

1200

1436

1612

1769

1300

1556

1746

1916

1400

1676

1880

2064

1600

1915

2149

2358

1800

2155

2417

2653

2000

2394

2686

2948

2200

2633

2955

3243

2400

2873

3223

3538

2600

3112

3492

3832

2800

3352

3760

4127

3000

3591

4029

4422

3200

3830

4298

4717

3400

4070

4566

5012

3600

4309

4835

5306

3800

4549

5103

5601

4000

4788

5372

5896

Watts/m 70/55/20

963

1079

1182

Watts/m 55/45/20

605

675

736

Water content l/m

5,55

6,66

7,77

Weight kg/m

30,89

36,93

42,96

Radiator exponent n







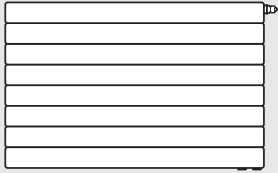

1,34

1,35

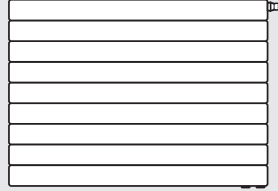
1,36

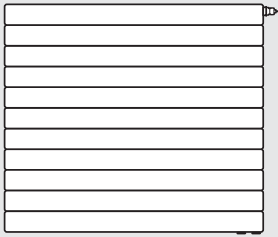

Heating output in compliance with DIN EN 442, and ÖNORM EN 442, at 75/65/20° C

Side panels and top cover are included in the heat output specifications

 Overall depth 93 mm	 	 	 
 Overall height [mm]	574	646	790
Model	VHV 22	VHV 22	VHV 22
 Overall length [mm]	Output [Watts]	Output [Watts]	Output [Watts]
500	796	850	943
600	955	1019	1132
700	1114	1189	1320
800	1274	1359	1509
900	1433	1529	1697
1000	1592	1699	1886
1100	1751	1869	2075
1200	1910	2039	2263
1300	2070	2209	2452
1400	2229	2379	2640
1600	2547	2718	3018
1800	2866	3058	3395
2000	3184	3398	3772
2200	3502	3738	4149
2400	3821	4078	4526
2600	4139	4417	4904
2800	4458	4757	5281
3000	4776	5097	5658
3200	5094	5437	6035
3400	5413	5777	6412
3600	5731	6116	6790
3800	6050	6456	7167
4000	6368	6796	7544
Watts/m 70/55/20	1274	1357	1500
Watts/m 55/45/20	790	838	919
Water content l/m	8,88	9,99	12,22
Weight kg/m	49,01	55,05	63,06
Radiator exponent n	1,37	1,38	1,41

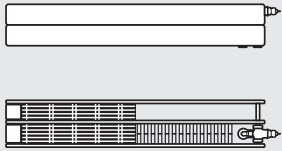
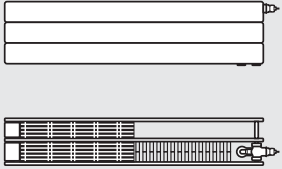
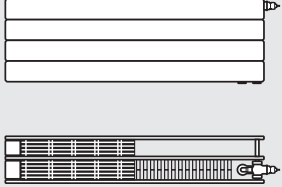

Heating output in compliance with DIN EN 442, and ÖNORM EN 442, at 75/65/20° C

Side panels and top cover are included in the heat output specifications

 Overall depth 163 mm	WVO-design	WVO-design	WVO-design
			
 Overall height [mm]	142	214	286
Model	VHV-S 22	VHV-S 22	VHV-S 22
 Overall length [mm]	Output [Watts]	Output [Watts]	Output [Watts]
500	321	419	516
600	385	503	619
700	449	587	722
800	513	670	826
900	577	754	929
1000	641	838	1032
1100	705	922	1135
1200	769	1006	1238
1300	833	1089	1342
1400	897	1173	1445
1600	1026	1341	1651
1800	1154	1508	1858
2000	1282	1676	2064
2200	1410	1844	2270
2400	1538	2011	2477
2600	1667	2179	2683
2800	1795	2346	2890
3000	1923	2514	3096
3200	2051	2682	3302
3400	2179	2849	3509
3600	2308	3017	3715
3800	2436	3184	3922
4000	2564	3352	4128
Watts/m 70/55/20	519	674	825
Watts/m 55/45/20	330	423	510
Water content l/m	2,18	3,34	4,44
Weight kg/m	19,43	28,34	37,24
Radiator exponent n	1,30	1,34	1,38

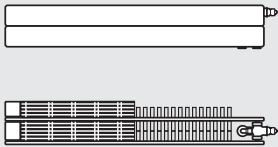
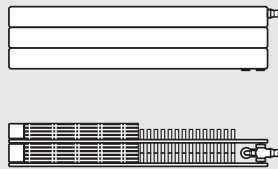
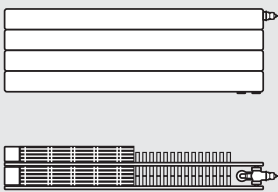

Heating output in compliance with DIN EN 442, and ÖNORM EN 442, at 75/65/20° C

Side panels and top cover are included in the heat output specifications

 Overall depth 150 mm			
 Overall height [mm]	142	214	286
Model	VHV 23	VHV 23	VHV 23
 Overall length [mm]	Output [Watts]	Output [Watts]	Output [Watts]
500	399	518	631
600	478	621	757
700	558	725	883
800	638	828	1009
900	717	932	1135
1000	797	1035	1261
1100	877	1139	1387
1200	956	1242	1513
1300	1036	1346	1639
1400	1116	1449	1765
1600	1275	1656	2018
1800	1435	1863	2270
2000	1594	2070	2522
2200	1753	2277	2774
2400	1913	2484	3026
2600	2072	2691	3279
2800	2232	2898	3531
3000	2391	3105	3783
3200	2550	3312	4035
3400	2710	3519	4287
3600	2869	3726	4540
3800	3029	3933	4792
4000	3188	4140	5044
Watts/m 70/55/20	645	832	1008
Watts/m 55/45/20	410	522	623
Water content l/m	2,18	3,34	4,44
Weight kg/m	17,02	24,84	32,66
Radiator exponent n	1,30	1,34	1,38



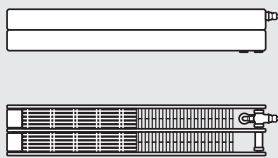
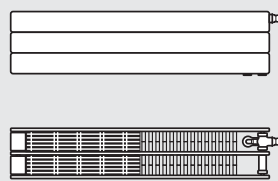
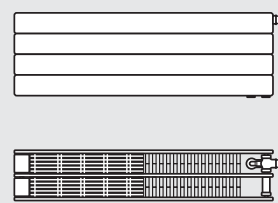



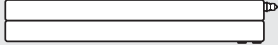

Heating output in compliance with DIN EN 442, and ÖNORM EN 442, at 75/65/20° C

Side panels and top cover are included in the heat output specifications

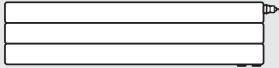
 Overall depth 175 mm			
 Overall height [mm]	142	214	286
Model	VHV 34	VHV 34	VHV 34
 Overall length [mm]	Output [Watts]	Output [Watts]	Output [Watts]
500	525	697	862
600	630	836	1034
700	735	976	1206
800	840	1115	1378
900	945	1255	1551
1000	1050	1394	1723
1100	1155	1533	1895
1200	1260	1673	2068
1300	1365	1812	2240
1400	1470	1952	2412
1600	1680	2230	2757
1800	1890	2509	3101
2000	2100	2788	3446
2200	2310	3067	3791
2400	2520	3346	4135
2600	2730	3624	4480
2800	2940	3903	4824
3000	3150	4182	5169
3200	3360	4461	5514
3400	3570	4740	5858
3600	3780	5018	6203
3800	3990	5297	6547
4000	4200	5576	6892
Watts/m 70/55/20	856	1123	1377
Watts/m 55/45/20	552	707	851
Water content l/m	3,33	4,99	6,66
Weight kg/m	23,93	35,18	46,42
Radiator exponent n	1,26	1,33	1,38

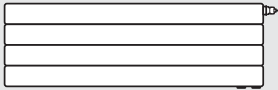
Heating output in compliance with DIN EN 442, and ÖNORM EN 442, at 75/65/20° C

Side panels and top cover are included in the heat output specifications

	WVO-design	WVO-design	WVO-design
 Overall depth 245 mm	 	 	 
 Overall height [mm]	142	214	286
Model	VHV-S 34	VHV-S 34	VHV-S 34
 Overall length [mm]	Output [Watts]	Output [Watts]	Output [Watts]
500	525	697	862
600	630	836	1034
700	735	976	1206
800	840	1115	1378
900	945	1255	1551
1000	1050	1394	1723
1100	1155	1533	1895
1200	1260	1673	2068
1300	1365	1812	2240
1400	1470	1952	2412
1600	1680	2230	2757
1800	1890	2509	3101
2000	2100	2788	3446
2200	2310	3067	3791
2400	2520	3346	4135
2600	2730	3624	4480
2800	2940	3903	4824
3000	3150	4182	5169
3200	3360	4461	5514
3400	3570	4740	5858
3600	3780	5018	6203
3800	3990	5297	6547
4000	4200	5576	6892
Watts/m 70/55/20	856	1123	1377
Watts/m 55/45/20	552	707	851
Water content l/m	3,33	4,99	6,66
Weight kg/m	29,39	42,92	56,44
Radiator exponent n	1,26	1,33	1,38

Heating output in compliance with DIN EN 442, and ÖNORM EN 442, at 75/65/20° C

Side panels and top cover are included in the heat output specifications



Overall depth
232 mm

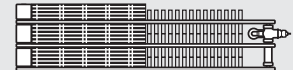
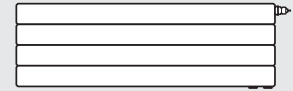
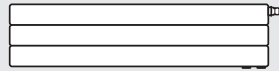
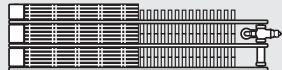
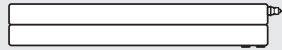

Overall height
[mm]

142

214

286

Model

VHV 35

VHV 35

VHV 35



Overall length
[mm]

Output
[Watts]

Output
[Watts]

Output
[Watts]

500

599

826

986

600

718

991

1183

700

838

1156

1380

800

958

1321

1577

900

1077

1486

1774

1000

1197

1651

1971

1100

1317

1816

2168

1200

1436

1981

2365

1300

1556

2146

2562

1400

1676

2311

2759

1600

1915

2642

3154

1800

2155

2972

3548

2000

2394

3302

3942

2200

2633

3632

4336

2400

2873

3962

4730

2600

3112

4293

5125

2800

3352

4623

5519

3000

3591

4953

5913

3200

3830

5283

6307

3400

4070

5613

6701

3600

4309

5944

7096

3800

4549

6274

7490

4000

4788

6604

7884

Watts/m 70/55/20

971

1326

1570

Watts/m 55/45/20

619

828

964

Water content l/m

3,33

4,99

6,66

Weight kg/m

26,98

39,42

51,86

Radiator exponent n





1,29

1,35

1,40

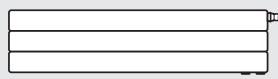
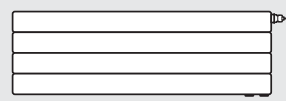

Heating output in compliance with DIN EN 442, and ÖNORM EN 442, at 75/65/20° C

Side panels and top cover are included in the heat output specifications

	Overall depth 257 mm					
	Overall height [mm]	142	214	286		
Model	VHV 46	VHV 46	VHV 46			
	Overall length [mm]	Output [Watts]	Output [Watts]	Output [Watts]		
500	727	1036	1224			
600	872	1243	1468			
700	1018	1450	1713			
800	1163	1658	1958			
900	1309	1865	2202			
1000	1454	2072	2447			
1100	1599	2279	2692			
1200	1745	2486	2936			
1300	1890	2694	3181			
1400	2036	2901	3426			
1600	2326	3315	3915			
1800	2617	3730	4405			
2000	2908	4144	4894			
2200	3199	4558	5383			
2400	3490	4973	5873			
2600	3780	5387	6362			
2800	4071	5802	6852			
3000	4362	6216	7341			
Watts/m 70/55/20	1179	1664	1949			
Watts/m 55/45/20	752	1040	1197			
Water content l/m	4,53	6,79	9,06			
Weight kg/m	33,89	49,76	65,62			
Radiator exponent n	1,29	1,35	1,40			

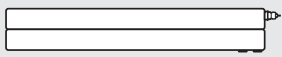
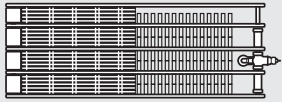
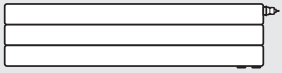
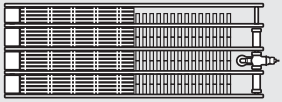
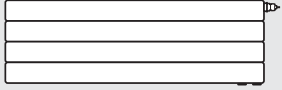
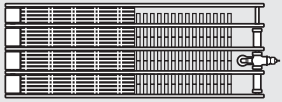

Heating output in compliance with DIN EN 442, and ÖNORM EN 442, at 75/65/20° C

Side panels and top cover are included in the heat output specifications

 Overall depth 327 mm	 	 	 
	 Overall height [mm]	142	214
Model	VHV-S 47	VHV-S 47	VHV-S 47
 Overall length [mm]	Output [Watts]	Output [Watts]	Output [Watts]
500	761	1151	1334
600	913	1381	1600
700	1065	1611	1867
800	1218	1842	2134
900	1370	2072	2400
1000	1522	2302	2667
1100	1674	2532	2934
1200	1826	2762	3200
1300	1979	2993	3467
1400	2131	3223	3734
1600	2435	3683	4267
1800	2740	4144	4801
2000	3044	4604	5334
2200	3348	5064	5867
2400	3653	5525	6401
2600	3957	5985	6934
2800	4262	6446	7468
Watts/m 70/55/20	1240	1846	2128
Watts/m 55/45/20	800	1149	1311
Water content l/m	4,53	6,79	9,06
Weight kg/m	41,27	60,50	79,74
Radiator exponent n	1,26	1,36	1,39

Heating output in compliance with DIN EN 442, and ÖNORM EN 442, at 75/65/20° C

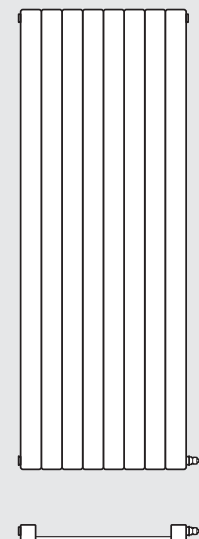
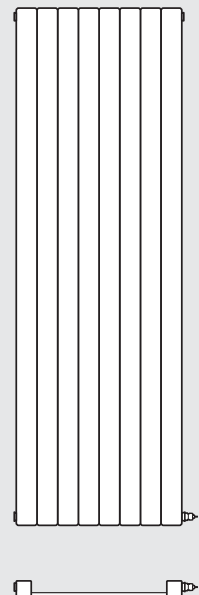
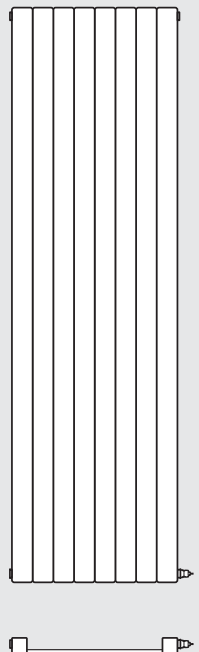
Side panels and top cover are included in the heat output specifications

									
Overall depth 68 mm									
	1600			1800			2000		
Model	VSV 10			VSV 10			VSV 10		
	Output [Watts]			Output [Watts]			Output [Watts]		
214	372			424			478		
286	497			566			638		
358	622			708			799		
430	747			851			960		
502	872			993			1120		
574	998			1136			1281		
646	1123			1278			1442		
718	1248			1421			1603		
790	1373			1563			1763		
862	1498			1706			1924		
Watts/m 70/55/20	1384			1577			1781		
Watts/m 55/45/20	850			968			1097		
Water content l/m	11,37			12,47			13,85		
Weight kg/m	44,45			49,60			54,75		
Radiator exponent n	1,40			1,40			1,39		

Heating output in compliance with DIN EN 442, and ÖNORM EN 442, at 75/65/20° C

Side panels and top cover are included in the heat output specifications



Overall depth
68 mm

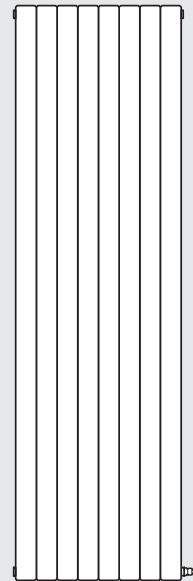
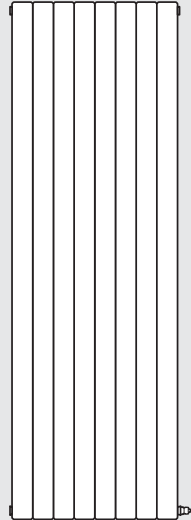
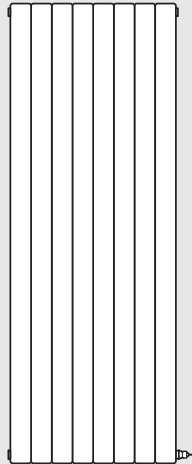

Overall height
[mm]

1600

1800

2000

Model

VSV 11

VSV 11

VSV 11



Overall length
[mm]

Output
[Watts]

Output
[Watts]

Output
[Watts]

214

424

473

524

286

566

632

701

358

708

791

877

430

851

950

1054

502

993

1109

1230

574

1136

1268

1406

646

1278

1427

1583

718

1421

1586

1759

790

1563

1745

1936

862

1706

1904

2112

Watts/m 70/55/20

1584

1768

1964

Watts/m 55/45/20

983

1097

1223

Water content l/m

11,37

12,47

13,85

Weight kg/m

63,39

68,53

73,69

Radiator exponent n







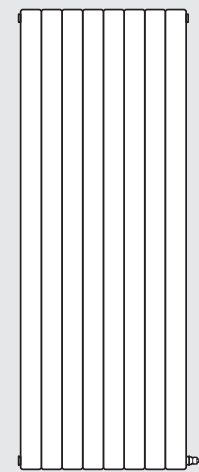

1,37

1,37

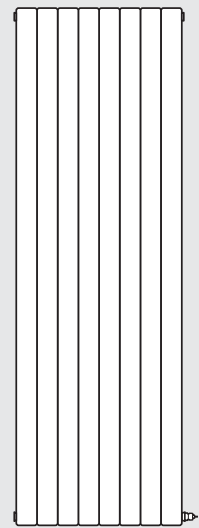
1,36

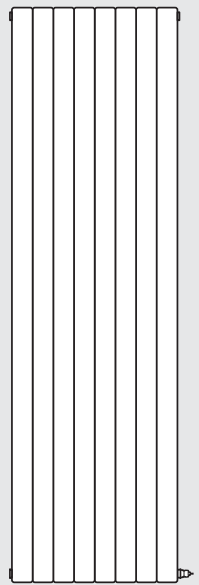
Heating output in compliance with DIN EN 442, and ÖNORM EN 442, at 75/65/20° C

Side panels and top cover are included in the heat output specifications

	 			 			 			
Overall depth 93 mm										
	Overall height [mm]	1600			1800			2000		
Model	VSV 20			VSV 20			VSV 20			
	Overall length [mm]	Output [Watts]	Output [Watts]	Output [Watts]						
214	627	706	786							
286	839	944	1050							
358	1050	1182	1315							
430	1261	1419	1579							
502	1472	1657	1843							
574	1683	1895	2108							
646	1894	2132	2372							
718	2105	2370	2636							
790	2316	2608	2901							
862	2527	2845	3165							
Watts/m 70/55/20	2332	2629	2929							
Watts/m 55/45/20	1427	1615	1805							
Water content l/m	22,74	24,34	27,71							
Weight kg/m	85,44	95,46	105,48							
Radiator exponent n	1,41	1,40	1,39							

Heating output in compliance with DIN EN 442, and ÖNORM EN 442, at 75/65/20° C

Side panels and top cover are included in the heat output specifications



Overall depth
93 mm

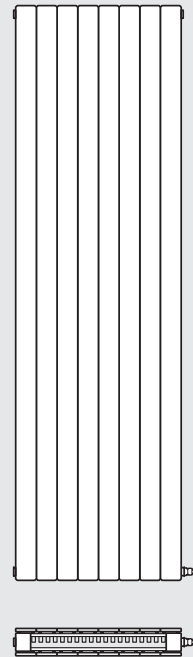
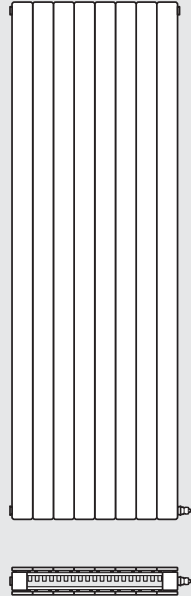
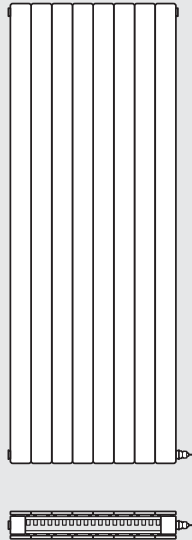

Overall height
[mm]

1600

1800

2000

Model

VSV 21

VSV 21

VSV 21



Overall length
[mm]

Output
[Watts]

Output
[Watts]

Output
[Watts]

214

681

768

859

286

911

1026

1147

358

1140

1285

1436

430

1369

1543

1725

502

1598

1801

2014

574

1828

2060

2303

646

2057

2318

2592

718

2286

2576

2881

790

2515

2835

3169

862

2745

3093

3458

Watts/m 70/55/20

2536

2857

3206

Watts/m 55/45/20

1557

1755

1983

Water content l/m

22,74

24,34

27,71

Weight kg/m

104,37

114,39

124,42

Radiator exponent n

1,40

1,40

1,38

Central-connection radiator

VONARIS: the central-connection radiator in a fully welded horizontal design, with from 1 to 4 layers of steel rectangular water-flow pipes, arranged one-behind-the-other, each layer consisting of from 2 to 11 pipes arranged one-above-the-other. Vertical design with 1 or 2 layers of steel rectangular water-flow pipes, arranged one-behind-the-other, each layer consisting of from 3 to 12 steel pipes, arranged side-by-side.

A 2 mm space between the heating pipes guarantees additional resistance to corrosion. **VONARIS** central-connection

radiators are equipped with a built-in valve set, suitable for either double-pipe or single-pipe operation, using a one-pipe manifold, with a factory-fitted valve (already installed) and protective cap.

Vertical central-connection radiators are delivered with a connection set, including a factory-fitted valve, a protective cap and a cover. Depending on the customer's preferences they will also be ready for double-pipe or single-pipe operation and for angled or through-flow connection. **VONARIS**

central-connection radiators are usually delivered with side panels. The horizontal design also comes equipped with a top cover. With the **VONARIS** central-connection radiators, brackets are not included as a matter of course (exception: VHV-M 11, where brackets are included).

The **VONARIS** central-connection radiator comes with a drain plug and a pivoting vent plug (with the vertical design, also two dummy plugs), all of them factory-sealed. **VONARIS** central-connection radiators are Design radiators that are ready to connect.

Standard design: rectangular steel pipes, 70 x 11 x 1.5 mm

High-pressure design: rectangular steel pipes, 70 x 11 x 2.0 mm

Dimensions:

Horizontal design: overall lengths between 500 mm and 1400 mm are available (at increments of 100 mm), and between 1600 mm and 2400 mm (at increments of 200 mm)

Horizontal design: the available overall heights are 142, 214, 286, 358, 430, 502, 574, 646 and 790 mm

Vertical design: overall lengths between 214 mm and 862 mm are available (at increments of 72 mm)

Vertical design: overall heights of 1600, 1800 and 2000 mm are available.

Coatings:

1. Undercoat: electrophoretic, using water-soluble paints, conforming to DIN 55900 part 1, stoved at 165° C;
2. Finish: electrostatic powder coating, conforming to DIN 55900 part 2, in a state-of-the-art facility. (On request, and at a supplementary charge, a range of RAL and sanitary ware colours can be offered.) This particularly robust coating is stoved at an object temperature of 180° C.

- Packaging:**
1. Cardboard packaging
 2. Edge protection
 3. Shrink foil



Connections:

Horizontal design: 2 x external thread G 3/4", bottom centre

Vertical design: 2 x external thread G 3/4", bottom centre



Maximum positive operating pressure

Standard design: 5 bar



Maximum positive operating pressure:

High-pressure design (supplementary charge): 8 bar



Maximum operating temperature: 110° C

Quality certificates

Strong brands of the highest quality

VOGEL&NOOT offers its customers strong brands that meet highest quality standards. All the production sites' production processes are certified according to ISO. The quality and performance specifications of the convectors and heating panels have been verified by recognised European institutions.

The standards that the quality certificates require us to maintain give you security, the best heating performance and premium product quality. For the **VOGEL&NOOT** warranty conditions, please see the installation sheet, which is enclosed with each **VONARIS/KONTEC** convector or heating panel.



Horizontal design, VHV-M models

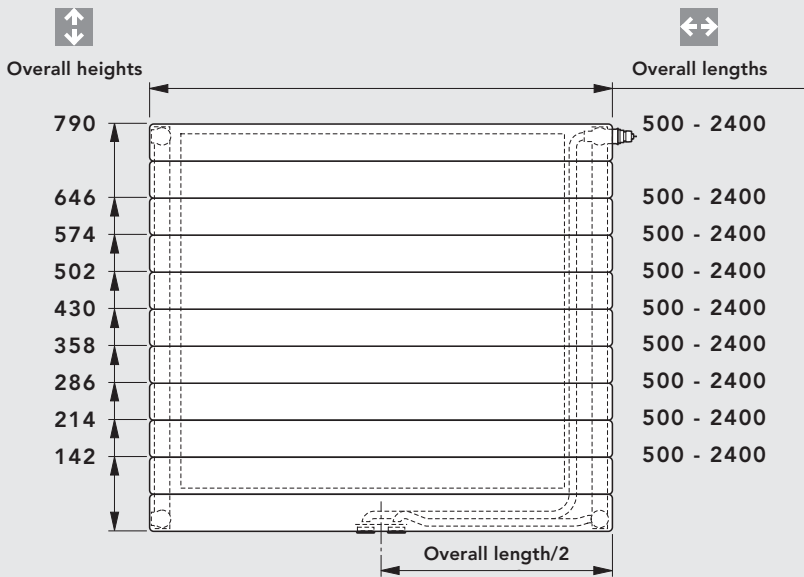
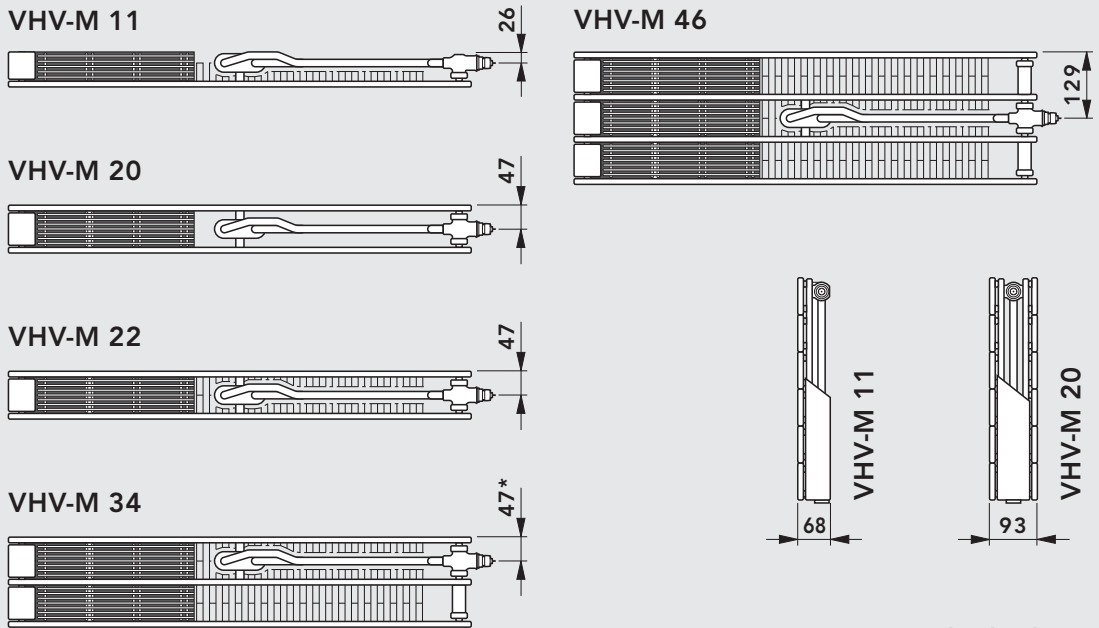

Schematic diagram

* **Note:** if the VHV-M 34 model is turned around so that the valve is located to the left, the distance between the VONARIS rear panel and the connection point is 129 mm.

Model	VHV-M 11			VHV-M 20			VHV-M 22				VHV-M 34		VHV-M 46	
Overall height ↑↓ [mm]	358	430	502	358	430	502	214	286	358	430	142	214	142	214
	574	646	790	574	646	790	502	574	646	790	286		286	
Overall length ↔ [mm]	500 - 2400 mm													
Increments	100 mm (for overall lengths of 1400 mm and above: 200 mm)													

Model overview / connection dimensions: vertical design, VSV-M models

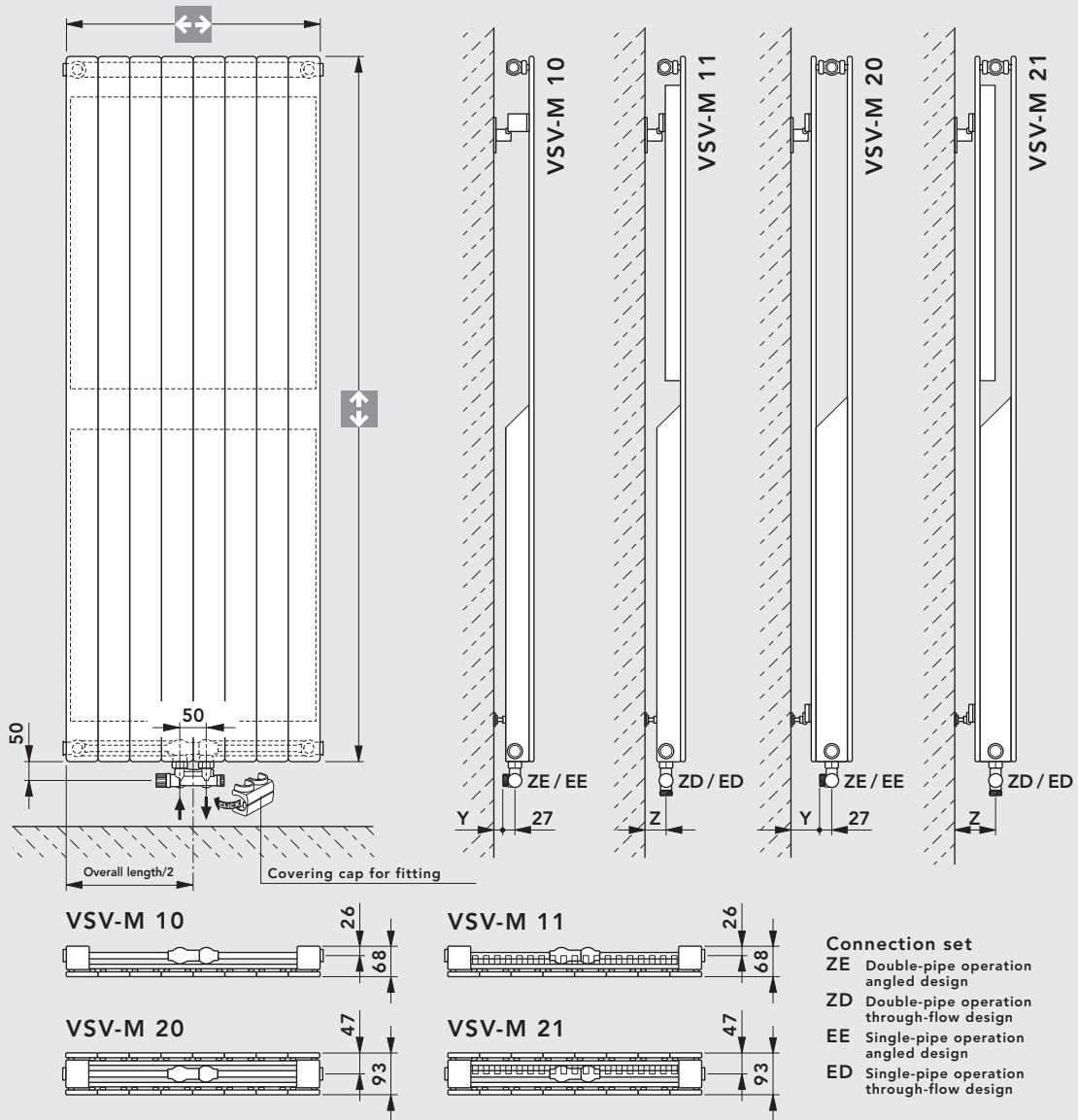

Connection set
 ZE Double-pipe operation angled design
 ZD Double-pipe operation through-flow design
 EE Single-pipe operation angled design
 ED Single-pipe operation through-flow design

Angled design connection set

Connection set in through-flow design

Angled design connection set			Connection set in through-flow design		
Fastening set	Model	Measurement Y [mm]	Fastening set	Model	Measurement Z [mm]
*	VSV-M 10	*	WA 10	VSV-M 10/11	35
WA 10	VSV-M 20/21	53	WA 10	VSV-M 20/21	79,5
*	VSV-M 11	*	WA 11	VSV-M 10/11	45
WA 11	VSV-M 20/21	63	WA 11	VSV-M 20/21	89,5

Schematic diagram

* **Note:** when installing the VSV-M 10 and VSV-M 11 models with an angled connection set (ZE, EE), please use the appropriate drill consoles and angled fishplates to ensure that the required distance from the wall is maintained.

Model	VSV-M 10			VSV-M 11			VSV-M 20			VSV-M 21		
Overall height	1600	1800	2000	1600	1800	2000	1600	1800	2000	1600	1800	2000
Overall length	214 - 862 mm											
Increments	72 mm											

Horizontal design

Model description

VHV-M 34 / 286 / 2000

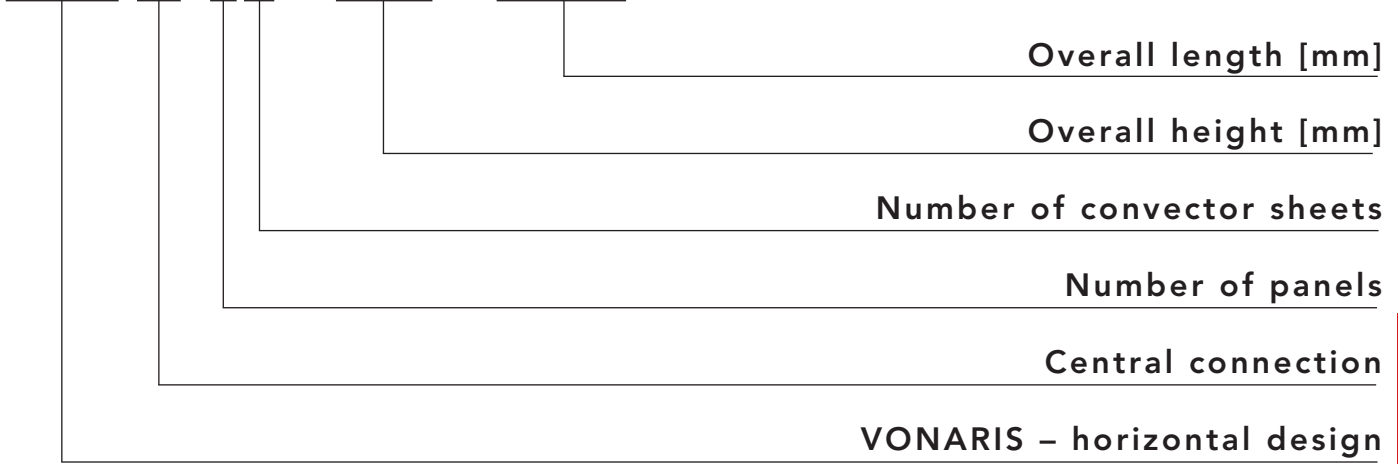

For each individual horizontal design order, the following data must be specified:

- Model (VHV-M)
- Overall height [mm]
- Overall length [mm]
- Specification of the RAL or Sanitary-Ware Colour number
- Positioning of the valve:
VR-valve to the right, **VL**- valve to the left.
 The VHV-M 20, VHV-M 22, VHV-M 34 and VHV-M 46 models without brackets are reversible, so that the valve can be positioned either to the right or to the left.
- Positive operating pressure (N ... (normal) standard design 5 bar / H ... high-pressure design 8 bar)
- Without brackets = 0 / with brackets = 1
 (By default the VHV-M models are delivered without brackets; exception: VHV-M 11 comes with brackets).

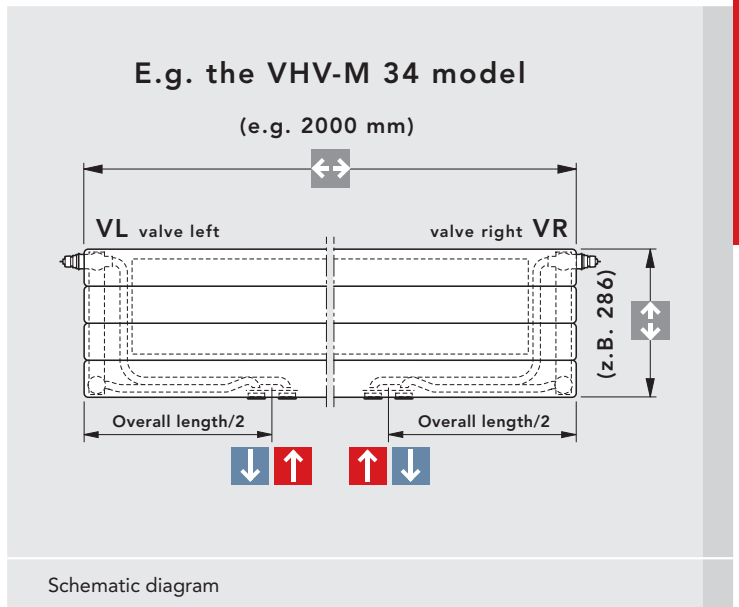

Order example:

1 item in horizontal design, valve left, VHV-M 34 model, overall height 286 mm, overall length 2000 mm, colour RAL 5024, with stand consoles SK 14 for use on finished floors, operating pressure 8 bar (high pressure design).

Example of an order form:

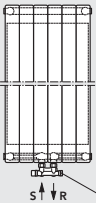
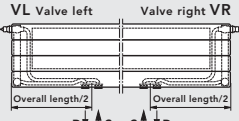
Pos./ Room	Num- ber	Model	Overall height ↕ [mm]	Overall length ↔ [mm]	Colour	 Connections VSV-M Connection set ZE Double-pipe operation angled design ZD Double-pipe operation through-flow design EE Single-pipe operation angled design ED Single-pipe operation through-flow design Connection set	 Valve positioning VHV-M VL Valve left Valve right VR Overall length/2 Overall length/2 R ↑ S ↓ S ↑ R ↓	Positive operating pressure = 0 with = 1	Brackets without = 0 with = 1	General accessories	
										Model	Number
-	1	VHV-M 34	286	2000	RAL 5024		VL: Valve to the left	H	0	SK 14	2

Vertical design

Model description

VSV-M 21 / 1600 / 574

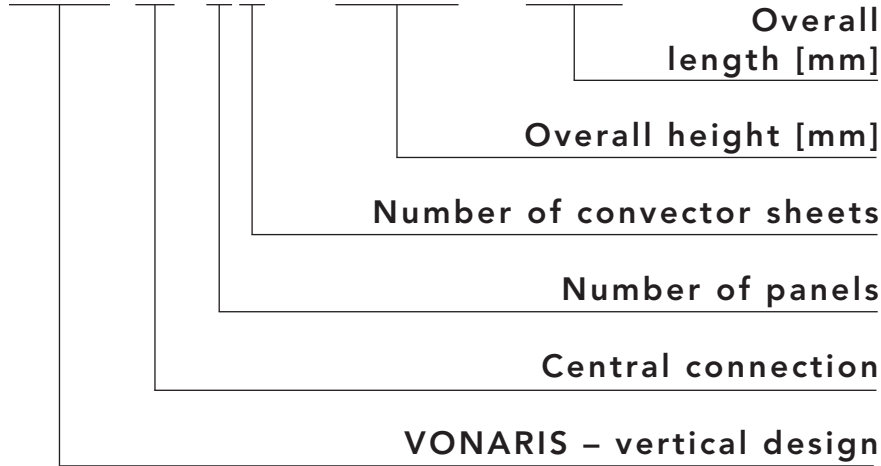

E.g. the VSV-M 21 model

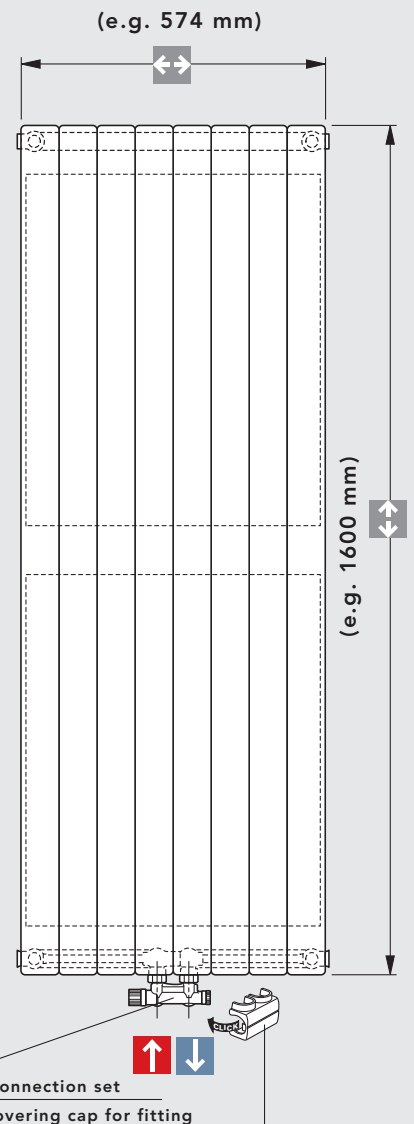

For each individual vertical design order, the following data must be specified:

- Model (VSV-M)
- Overall height [mm]
- Overall length [mm]
- Specification of the RAL or Sanitary-Ware Colour number
- Connection set mode:
 - ZE: Double-pipe operation – angled design
 - ZD: Double-pipe operation – through-flow design
 - EE: Single-pipe operation – angled design
 - ED: Single-pipe operation – through-flow design
- Positive operating pressure (N(normal) standard design 5 bar / H ...high-pressure design 8 bar)
- VSV-M models are delivered with brackets as standard

Note:

For the vertical design the supply is always on the left-hand side.

Order example:

1 item in vertical design, double-pipe operation, angled design, VSV-M 21 model, overall height 1600 mm, overall length 574 mm, colour VNF 3903, with 2 wall fastenings WA 11, operating pressure 8 bar (high pressure design).

Example for an order form:

Pos./ Room	Num- ber	Model	Overall height ↕ [mm]	Overall length ↔ [mm]	Colour	Connections VSV-M Connection set ZE Double-pipe operation angled design ZD Double-pipe operation through-flow design EE Single-pipe operation angled design ED Single-pipe operation through-flow design	Valve positioning VHV-M VL Valve left Valve right VR Overall length/2 Overall length/2 R ↑ S S ↑ R	Positive operating pressure	Brackets without = 0 with = 1	General accessories	
										Model	Number
-	1	VSV-M 21	1600	574	VNF 3903	ZE Double-pipe operation, angled design	H	1	WA 11	2	

Horizontal and vertical designs

It is easy to set the precise values required **without** using any special tools (see drawings).

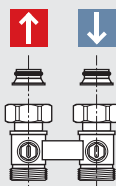
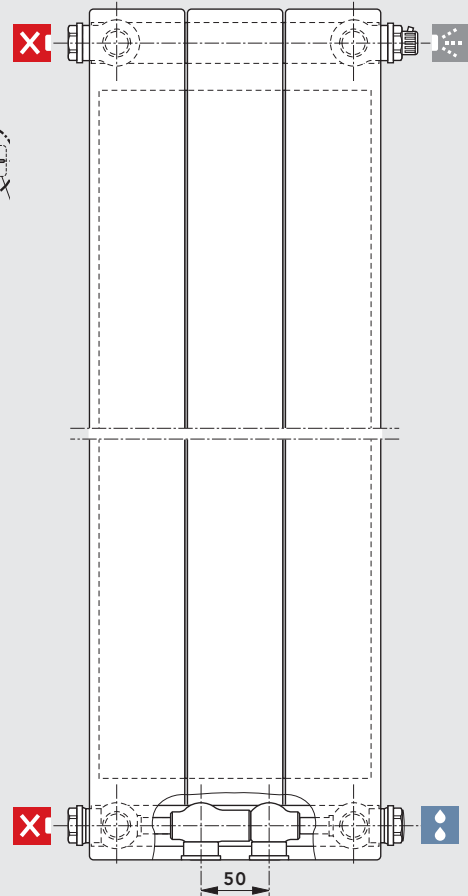
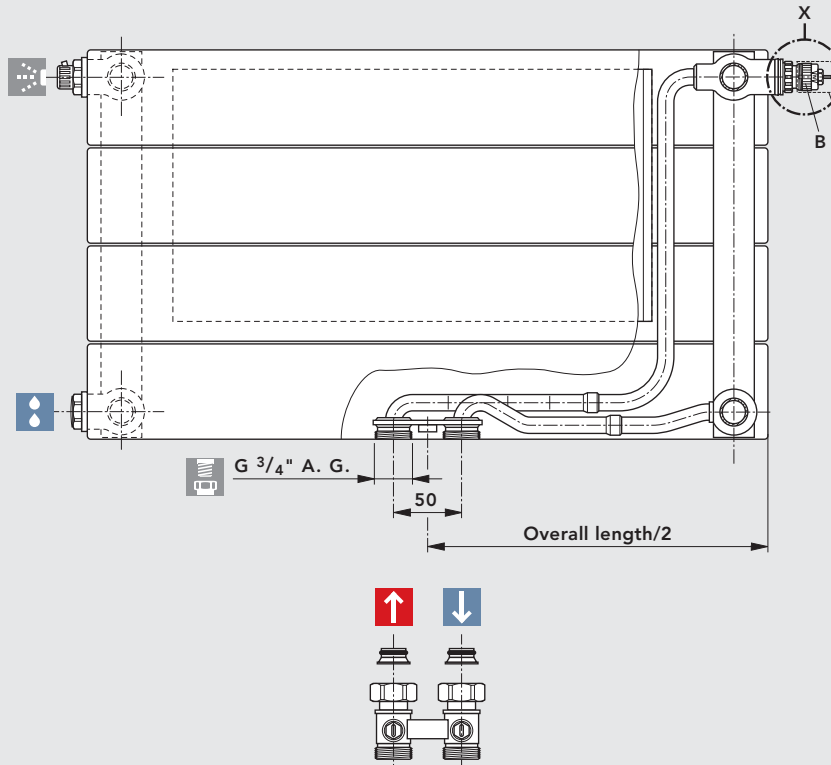

Note:
Settings in the hatched area must be avoided.

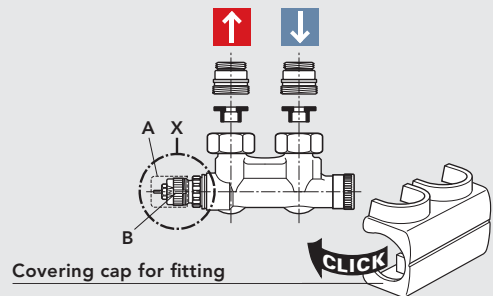
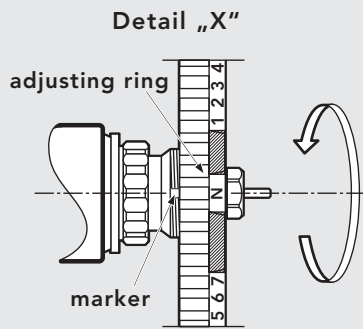

Schematic diagram

The radiator will be delivered with a fitted protective cap. After removing the protective cap (item A), the following thermostat heads can be installed directly onto the built-in valve (item B): „RA 2000“, or „RAW“ from Danfoss, „VK“ from Heimeier, „D“ from Herz, „thera DA“ from MNG, and „UNI XD“ from Oventrop.

Adjustment tips:

- Remove protective cap and sensor
- Lift the adjusting ring and turn it anti-clockwise, to the setting required – the set value (1, 2, ...7, N) needs to be directly in line with the marker.
- Presetting is possible in steps of 0.5 between 1 and 7. The „N“ setting, cancels all presetting.

Horizontal design

Guideline values for default settings

Basis:

Supply temperature **70 °C**

Return temperature **55 °C**

Room temperature **20 °C**

Default setting 1 $k_v = 0.13$
For radiators up to about 500 W

Default setting 2 $k_v = 0.21$
For radiators up to about 800 W

Default setting 3 $k_v = 0.26$
For radiators up to about 1000 W

Default setting 4 $k_v = 0.31$
For radiators up to about 1200 W

Default setting 5 $k_v = 0.41$
For radiators up to about 1600 W

Default setting 6 $k_v = 0.52$
For radiators up to about 2000 W

Default setting 7 $k_v = 0.63$
For radiators up to about 2400 W

Default setting N $k_v = 0.75$
For radiators of more than 2400 W

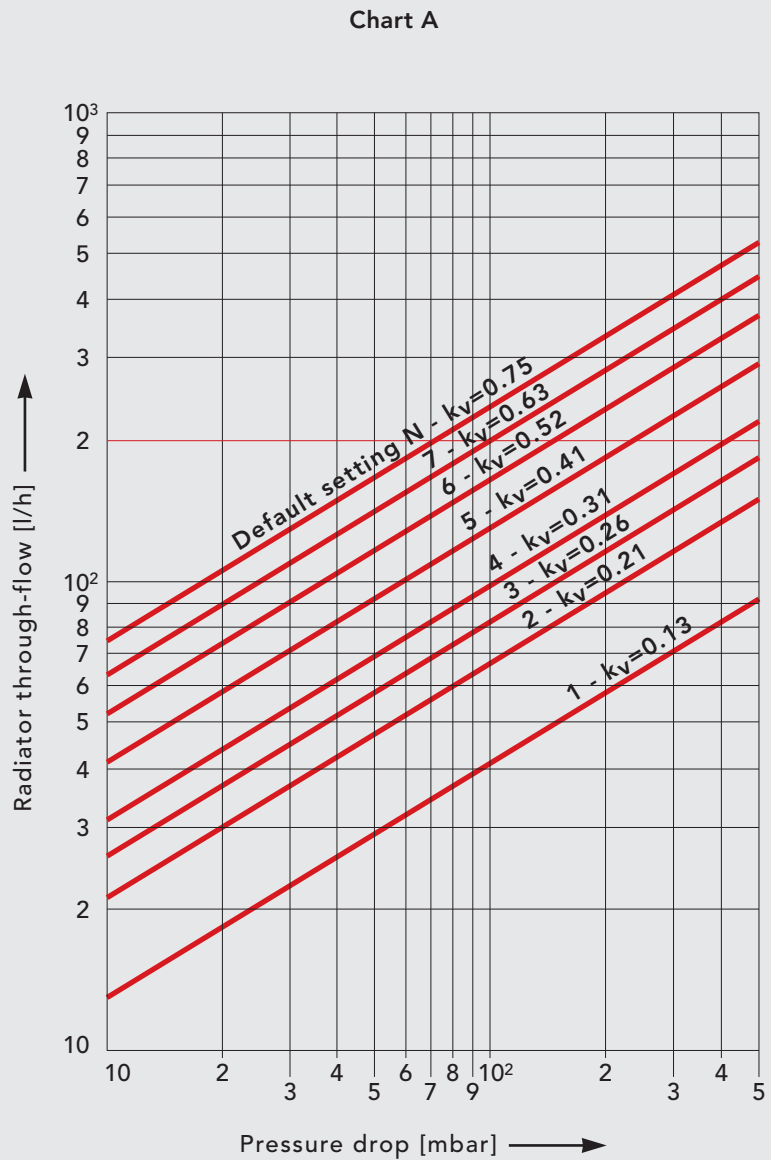

Chart A:

Pressure drop [mbar] – double-pipe operation at 2K proportional offset.

It is of course possible to adjust the valve default setting, whilst there is pressure in the heating system.

Vertical design

Guideline values for default settings

Basis:
 Supply temperature 70 °C
 Return temperature 55 °C
 Room temperature 20 °C

- Default setting **4** $k_v = 0.12$
 For radiators up to about 450 W
- Default setting **5** $k_v = 0.19$
 For radiators up to about 700 W
- Default setting **6** $k_v = 0.27$
 For radiators up to about 1000 W
- Default setting **7** $k_v = 0.33$
 For radiators up to about 1200 W
- Default setting **N** $k_v = 0.48$
 For radiators of more than 1200 W

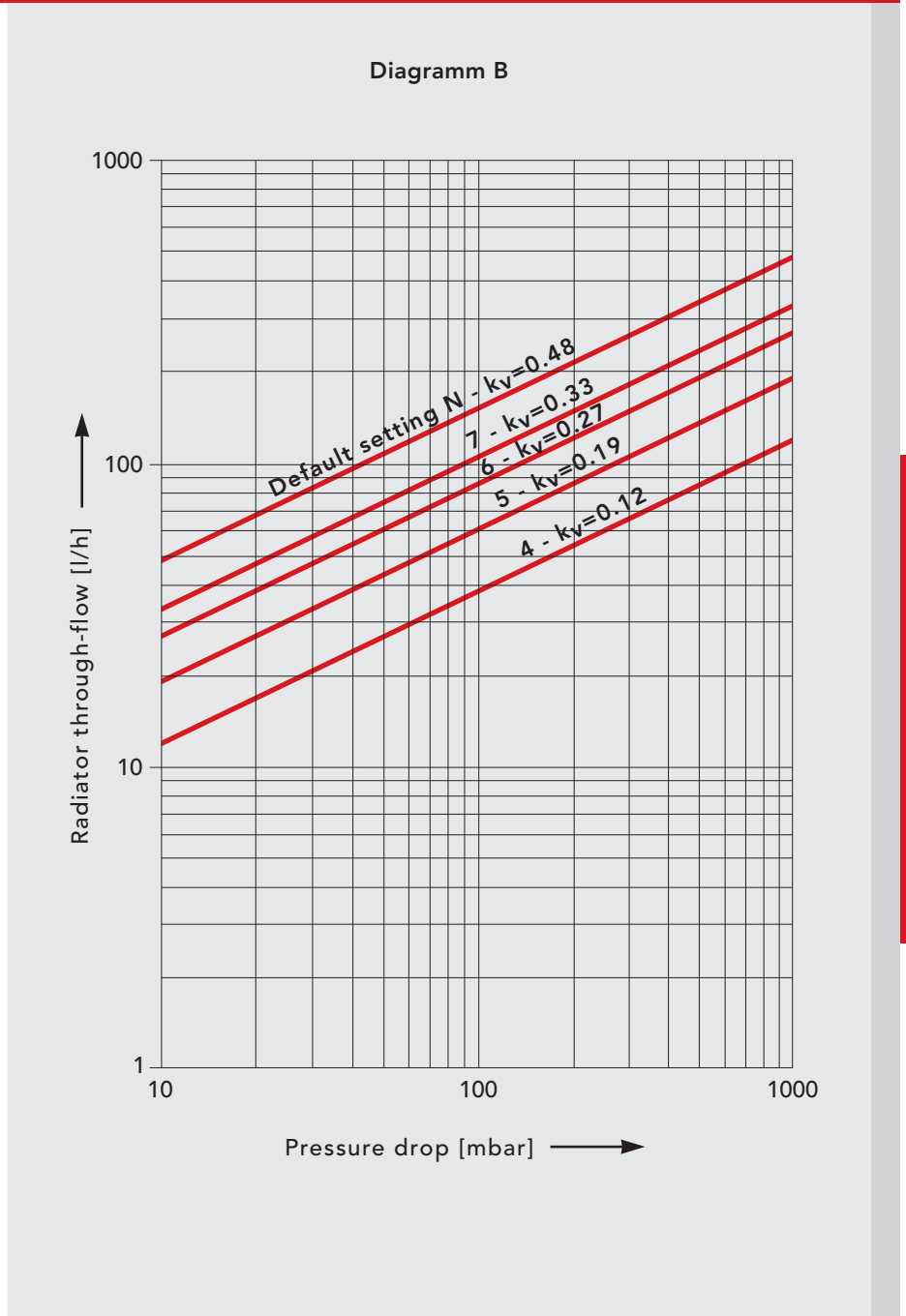

Chart B:

Pressure drop [mbar] – double-pipe operation at 2K proportional offset.

It is of course possible to adjust the valve default setting, whilst there is pressure in the heating system.

Horizontal and vertical design

For VHV-M models no valve default setting is necessary, as the valve is delivered factory-adjusted (default setting **N**).

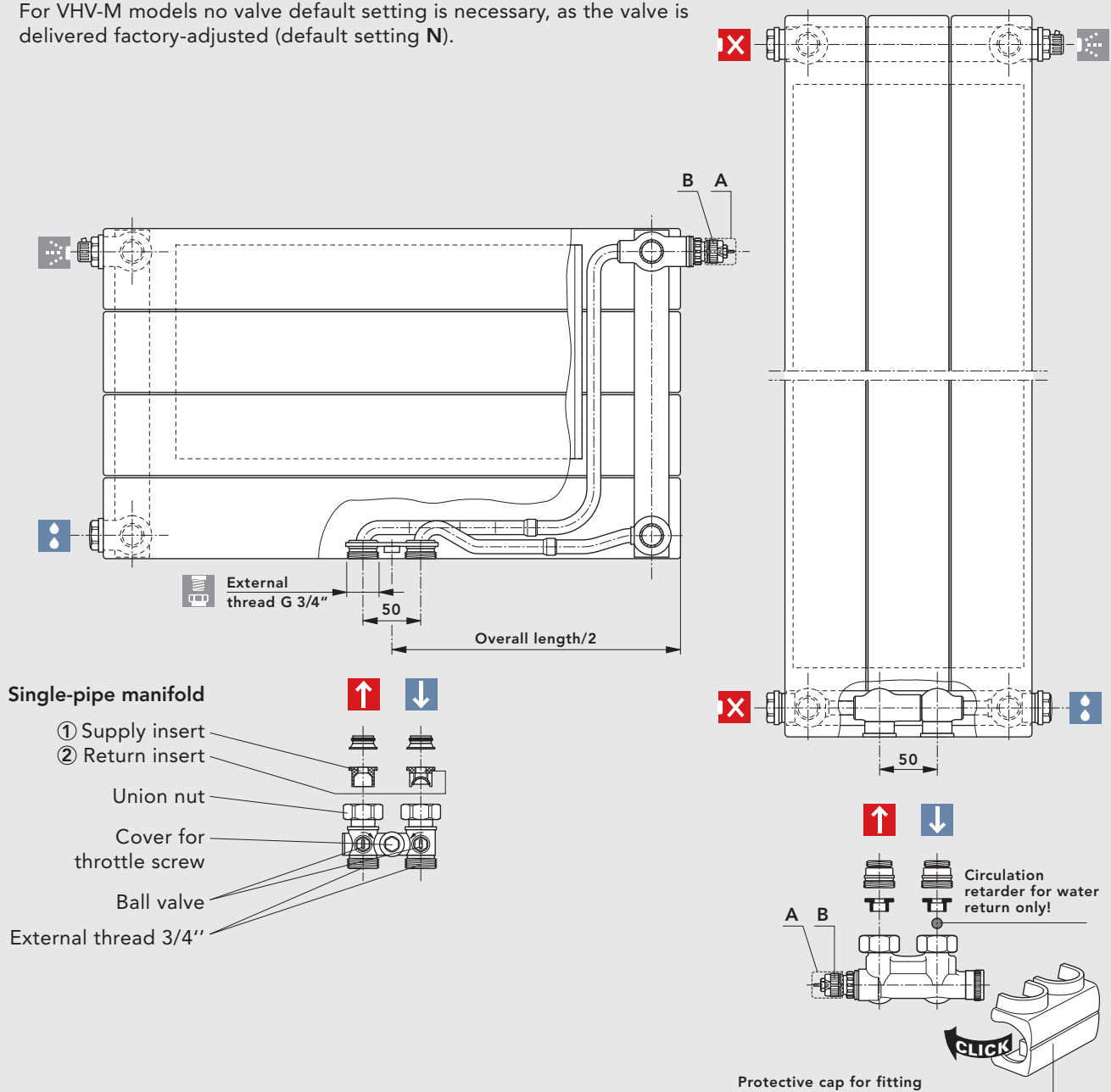

Schematic diagram

The radiator valve (VHV-M models) and the connection set (VSV-M models) will both be delivered with a fitted protective cap. After removing the protective cap (item A), the following thermostat heads can be installed directly onto the built-in valve (item B): „RA 2000“, or „RAW“ from Danfoss, „VK“ from Heimeier, „D“ from Herz, „thera DA“ from MNG, and „UNI XD“ from Oventrop.

Please note!

Horizontal design:

During the installation of the single-pipe manifold ensure that the return insert ② is installed in the water return, and the supply insert ① in the water supply.

Vertical design:

When fitting the single-pipe operation connection set, ensure that the **circulation retarder** is installed in the water return.

Horizontal design

Default setting when using a single-pipe manifold: radiator proportion 40 % --- 2.50 revolutions*
 radiator proportion 30 % --- 3.50 revolutions*
 radiator proportion 35 % --- 3 revolutions*
 radiator proportion 45 % --- 2 revolutions*
 radiator proportion 50 % --- 1.75 revolutions*

*... before starting, turn the bypass spindle of the single-pipe manifold to the **right as far as it will go**.

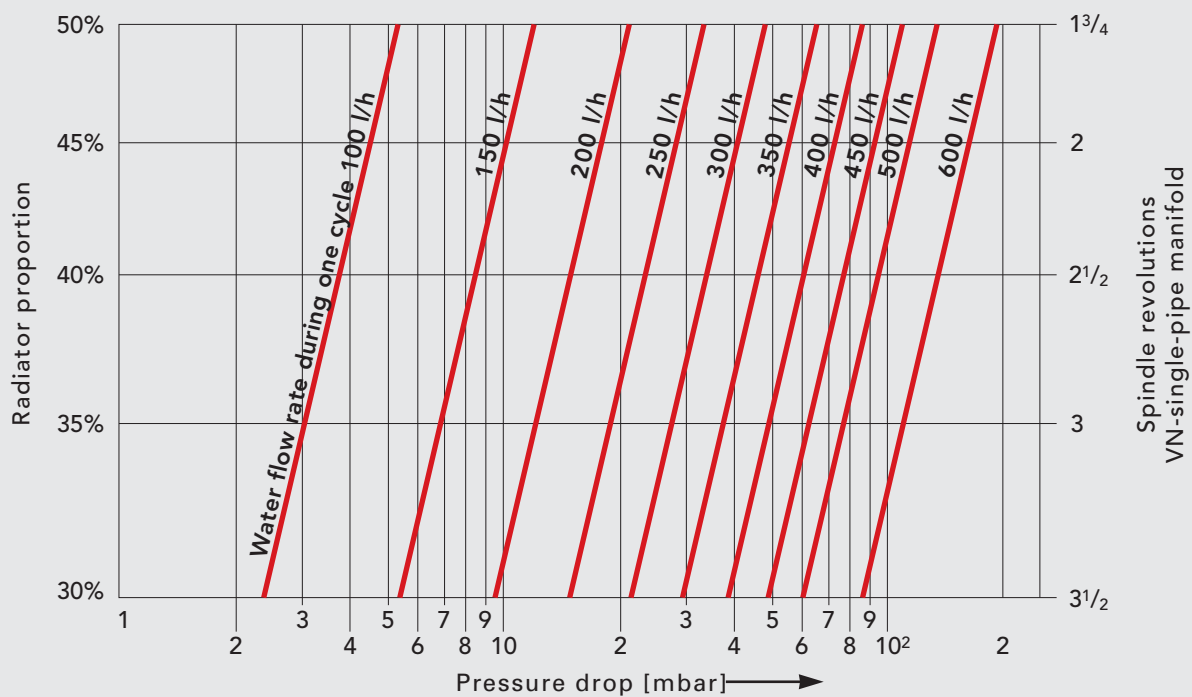

Diagram:

Pressure drop [mbar] – single-pipe operation with a proportional deviation of 2K.

It is of course possible to change the radiator proportion, whilst there is pressure in the heating system.







Please take account of the maximum power per cycle (for single-pipe installations) of about 10 kW:
 $\Delta T = T_1 - T_2 = 20 \text{ K}$ (at $T_1 = 90 \text{ }^\circ\text{C}$).

Vertical design

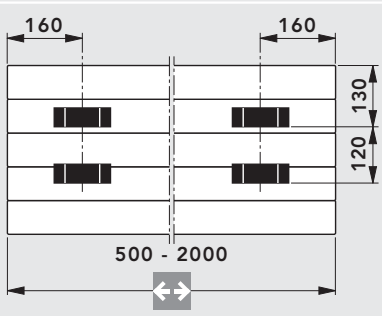
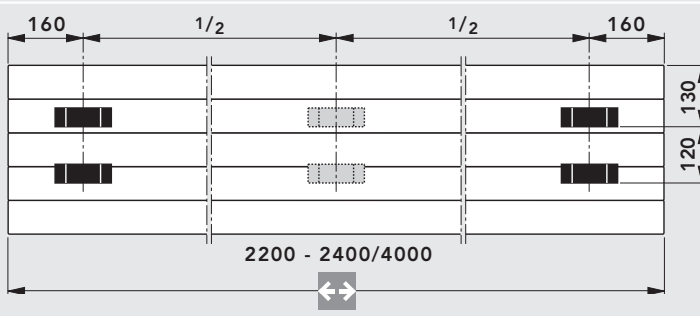
The connection set radiator proportion comes preset at 40 %.

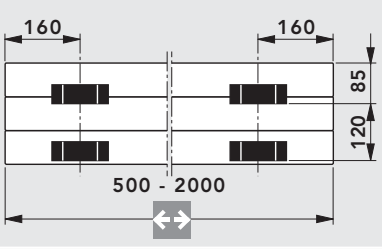
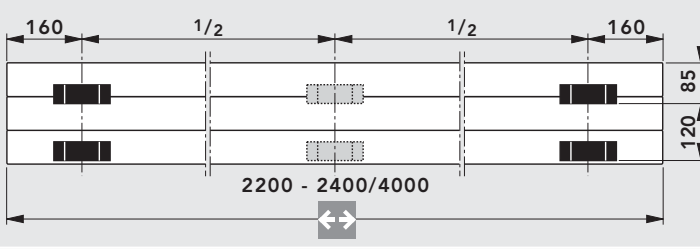
Please take account of the maximum power per cycle (for single-pipe installations) of about 10 kW:
 $\Delta T = T_1 - T_2 = 20 \text{ K}$ (at $T_1 = 90 \text{ }^\circ\text{C}$).

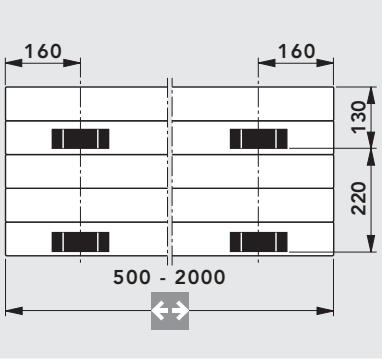
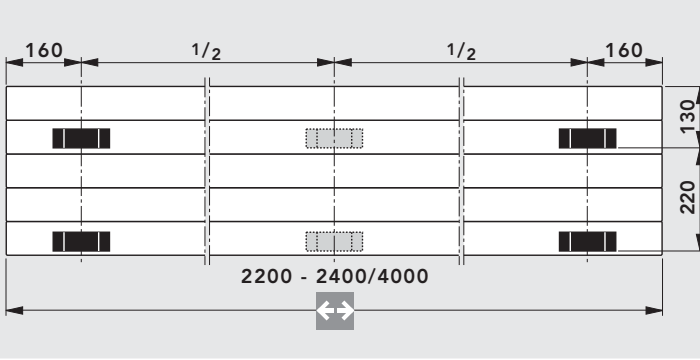
VONOMAT wall console for the VHV-M 11, VHV-M 20, VHV-M 22 and VHV-M 34 models

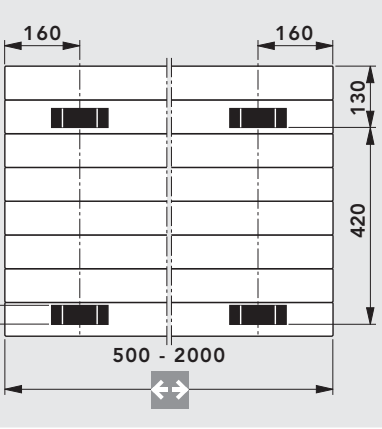
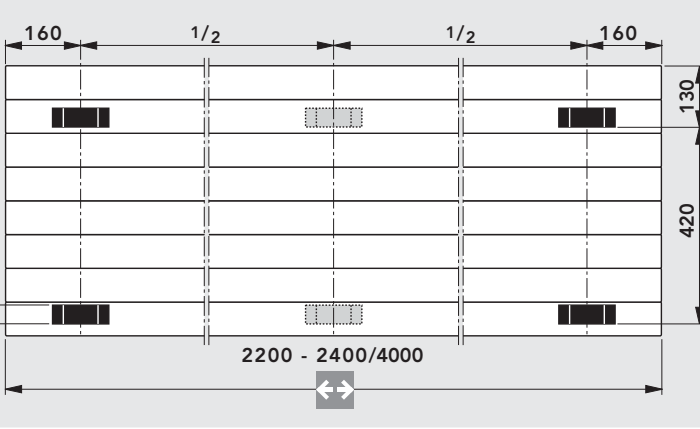
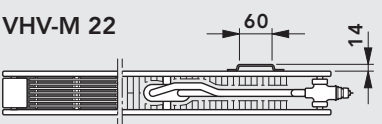
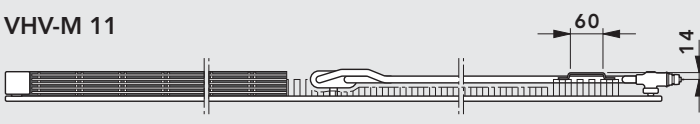
Model	VHV-M 11 for VONOMAT 300	
Overall height  358 mm		
VHV-M 22 and VHV 34 for VONOMAT 300		
Overall height  214 mm and 286 mm		
VHV-M 11, VHV-M 20/22 for VONOMAT 400		
Overall height  from 430 mm to 574 mm VHV-M 11, from 358 mm to 502 mm VHV-M 20/22		
VHV-M 11, VHV-M 20/22 for VONOMAT 600		
Overall height  from 646 mm to 790 mm VHV-M 11, from 574 mm to 790 mm VHV-M 20/22		
VHV-M 22 	VHV-M 11 	
Schematic diagram		

Please note! Of the horizontal design models only VHV-M 11 (OH 358 – 790 mm) is delivered with brackets as standard. If a **VONOMAT** wall console is to be used with the VHV-M 20 (OH 358 – 790 mm), VHV-22 (OH 214 – 790) and VHV 34 (142 – 286 mm), these models need to be ordered as special designs, equipped with brackets.

VONOMAT wall console, for models VHV-M 11, VHV-M 20, VHV-M 22 and VHV-M 34

The **VONARIS** central connection radiator can be installed easily, quickly and securely, whilst it is still in its wrapper. This is made possible by the **VONOMAT** wall console **with fitted brackets** for the horizontal designs of VHV-M 11 (OH 358 – 790 mm) VHV-M 20 (OH 358 – 790 mm), VHV-M 22 (OH 214 – 790 mm) and the VHV-M 34 (OH 214 and 286 mm).

Wall rails for OH 214 – 790

Drilling measurements for the VONOMAT 300 – 600

VONOMAT 300	Model	VHV-M Overall height [mm]	Value X [mm]	Value Y [mm]	Value Z [mm]	VONOMAT 400 / 600
	VHV-M 22, 34	214	34	114	100	
	VHV-M 22, 34	286	61	141	145	
	VHV-M 11	358	133	213	145	
	VHV-M 20, 22	358	58	209	149	
	VHV-M 11, 20, 22	430	130	281	149	
	VHV-M 11, 20, 22	502	202	353	149	
	VHV-M 11	574	274	425	149	
	VHV-M 20, 22	574	74	425	149	
	VHV-M 11, 20, 22	646	146	497	149	
	VHV-M 11, 20, 22	790	290	641	149	

Schematic diagram

The **VONOMAT** wall console with integrated connection and displacement locking features consists of:
 2 or *3 consoles with sound-proofing,
 2 or *3 snap-on elements,
 2 or *3 mounting screws with dowels and safety washers

*From overall lengths of 2200 mm and greater

Connection – wall clearance

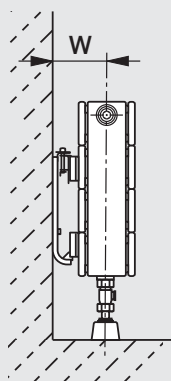

Horizontal design model	Overall height [mm]	Value W [mm]
VHV-M 11	358 - 790	43
VHV-M 20	358 - 790	87
VHV-M 22	214 - 790	87
VHV-M 34	214 / 286	87

The **VONOMAT** wall console complies with the requirements of the TÜV Rheinland (for physical load-bearing purposes).

Schematic diagram

VONOFIX rapid-installation console for the VHV-M models

VHV-M 20 models: OH 358 – 790 mm; VHV-M 22 models: OH 214 - 790 mm; and VHV-M 34 models: OH 214 and 286 mm

OH 214: for **VONOFIX 1**

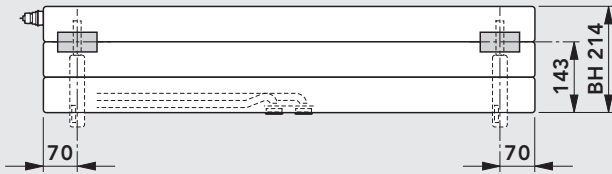

OH 574 and 646: for **VONOFIX 4**

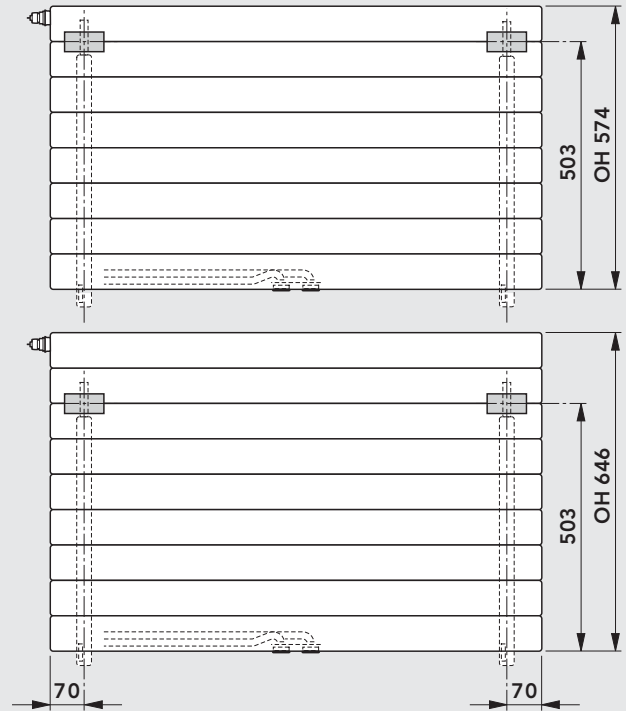

OH 286 and 358: for **VONOFIX 2**

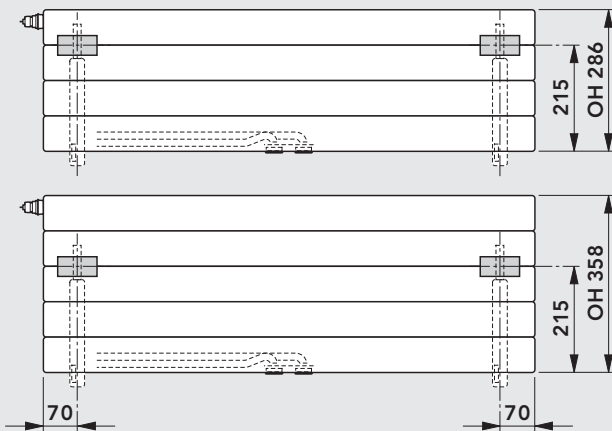

OH 430 and 502: for **VONOFIX 3**

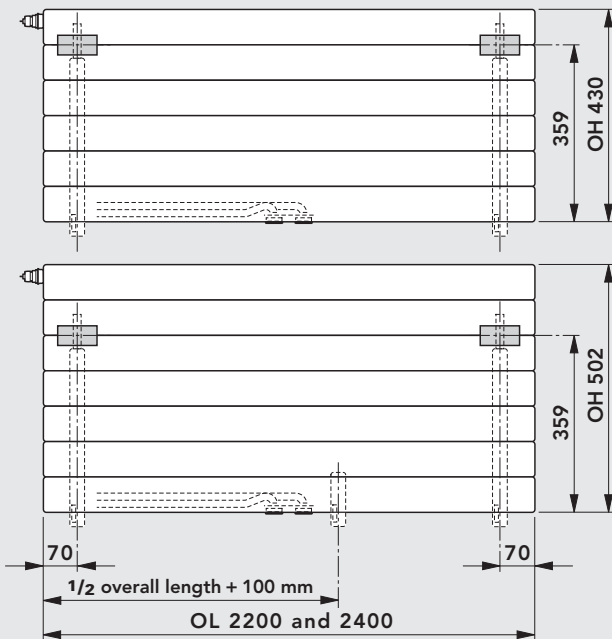

OH 790: for **VONOFIX 5**

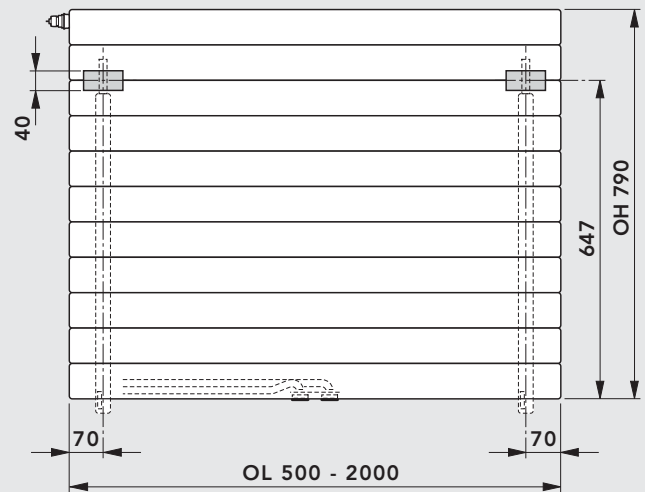

Note! for an overall length of 2200 mm and greater an additional piece of foot console must be used!

Schematic diagram

Important: the installation of VHV-M models with insertion (push-in) brackets is only feasible when using the VONOFIX rapid-installation console!

VONOFIX rapid-installation console for the VHV-M models

The **VONARIS** central connection radiator can be installed easily, quickly and securely. This is made possible by the **VONOFIX** rapid-installation console for the horizontal designs of the VHV-M 20 (OH 358 - 790 mm), VHV-M 22 (OH 214 - 790 mm) and the VHV-M 34 (OH 214 and 286 mm) models.

Wall rails for OH 214 – 790 mm

Drilling measurements for the VONOFIX 1 - 5

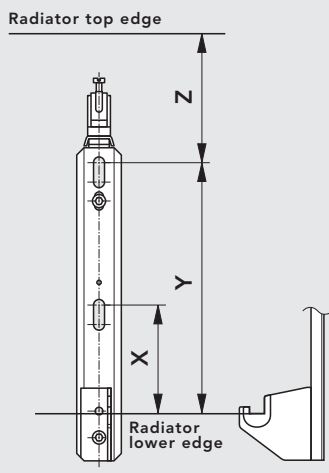

Overall radiator height [mm]	Value X [mm]	Value Y [mm]	Value Z [mm]
214	-	125	89
286	100	197	89
358	100	197	161
430	100	341	161
502	100	341	161
574	100	485	89
646	100	485	89
790	100	629	161

Schematic diagram

Vonaris-M

The **VONOFIX** rapid-installation console consists of:

- 2 wall consoles (zinc-plated), with sound-proofing filters, screws and dowels
- 2 stabilising brackets
- 2 insertion (push-in) brackets
- (For an overall length of 2200 mm and greater, 1 additional piece of foot console)

Connection – wall clearance

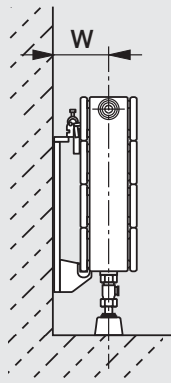

Horizontal design model	Overall height [mm]	Value W [mm]
VHV-M 20	358 – 790	91
VHV-M 22	214 – 790	91
VHV-M 34	214 – 286	91*

* **Note:** if the **VHV-M 34** is turned round and used as a left-hand design model, the measurement **W** is **172 mm**.

Schematic diagram

VSV-M models

Overall length

 [mm]

214

286

358

430 - 862

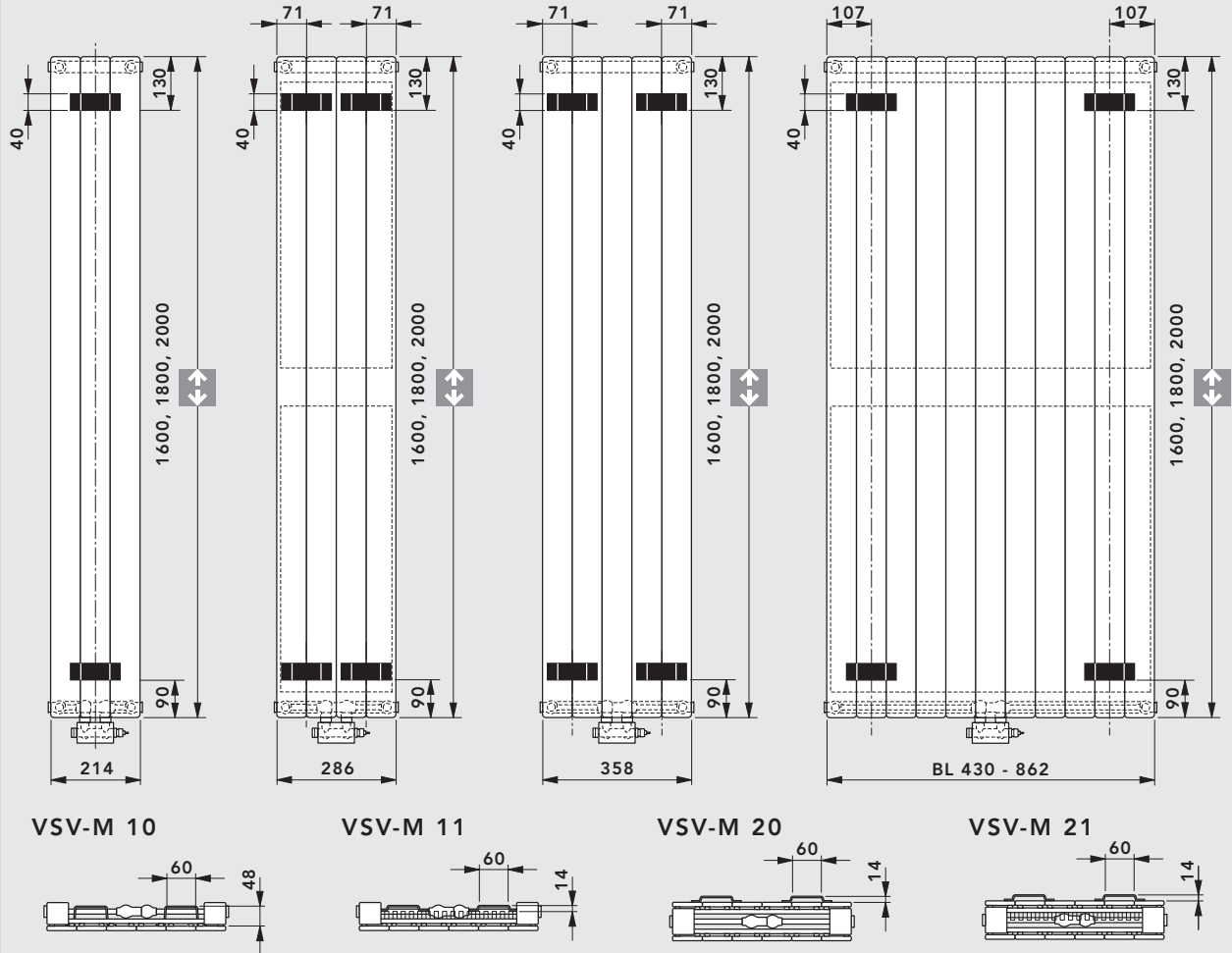

Schematic diagram

Wall clearance measurements: WA 10 and WA 11 wall mounting brackets for the VSV-M models

Connection - wall clearance

Wall mounting brackets model	Vertical design model	Value W [mm]
WA 10	VSV-M 10/11*	35
WA 10	VSV-M 20/21	79,5
WA 11	VSV-M 10/11*	45
WA 11	VSV-M 20/21	89,5

***Note!** if you are using WA 10 or WA 11 wall mounting brackets for the installation of the VSV-M 10 or VSV-M 11 model with a right-angled-design connection, please follow the instructions in the diagram on page 44.

Schematic diagram

SK 12 – 17 stand consoles: positioning with the VHV-M models (up to an overall height of 286 mm)

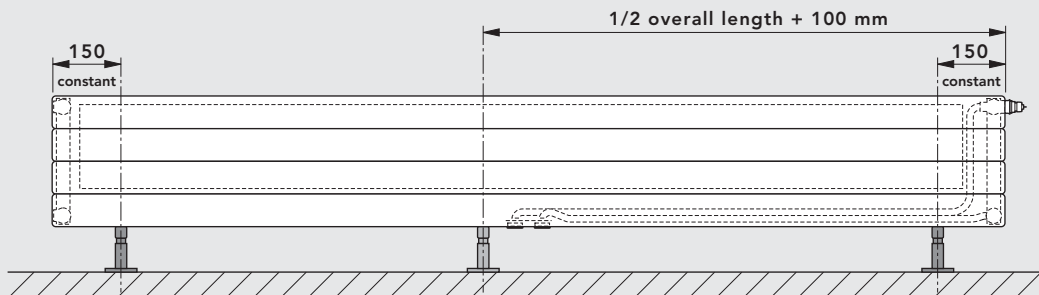

Note: for an overall length of 2200 mm and greater, a 3rd stand console must be used!

SK 12 / SK 13
VHV-M 22

SK 14 / SK 15
VHV-M 34

SK 16 / SK 17
VHV-M 46

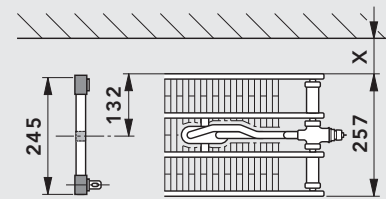
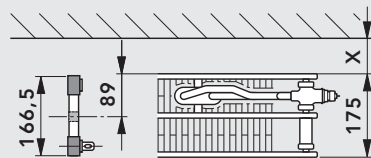
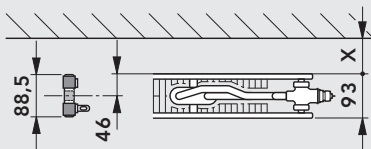

Schematic diagram

FBT 20 window sill support: positioning for the VHV-M models (up to an overall height of 286 mm)

Window sill support for subsequent installation with the VHV-M 22 – 46 models of the VONARIS-M central connection radiator (up to an overall height of 286 mm)

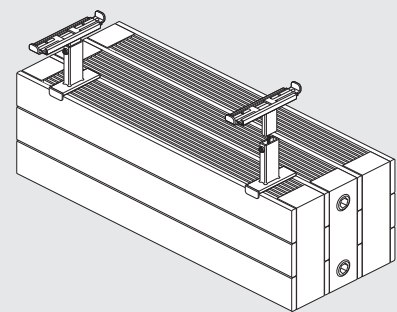
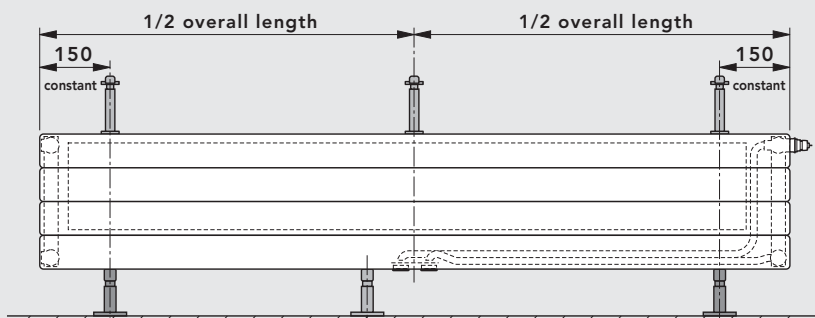



Note: for an overall length of more than 2200 mm, a 3rd window sill support must be used!

Schematic diagram

Heating output in compliance with DIN EN 442, and ÖNORM EN 442, at 75/65/20° C

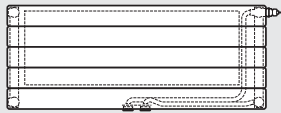
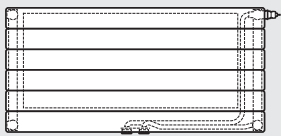
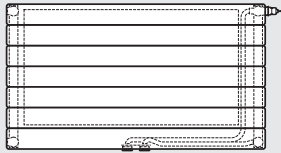
Side panels and top cover are included in the heat output specifications

	Overall depth 68 mm					
	Overall height [mm]	358	430	502		
Model	VHV-M 11	VHV-M 11	VHV-M 11			
	Overall length [mm]	Output [Watts]	Output [Watts]	Output [Watts]		
500	313	359	402			
600	375	431	482			
700	438	503	563			
800	500	574	643			
900	563	646	724			
1000	625	718	804			
1100	688	790	884			
1200	750	862	965			
1300	813	933	1045			
1400	875	1005	1126			
1600	1000	1149	1286			
1800	1125	1292	1447			
2000	1250	1436	1608			
2200	1375	1580	1769			
2400	1500	1723	1930			
Watts/m 70/55/20	505	583	652			
Watts/m 55/45/20	320	372	415			
Water content l/m	2,78	3,33	3,87			
Weight kg/m	16,71	19,85	22,99			
Radiator exponent n	1,31	1,29	1,29			

Heating output in compliance with DIN EN 442, and ÖNORM EN 442, at 75/65/20° C

Side panels and top cover are included in the heat output specifications



Overall depth 68 mm

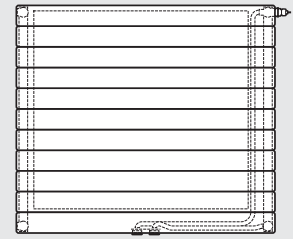
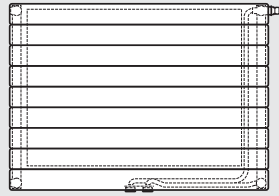
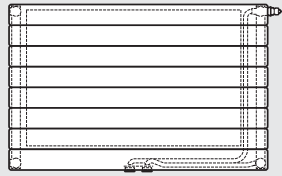

Overall height [mm]

574

646

790

Model

VHV-M 11

VHV-M 11

VHV-M 11



Overall length [mm]

Output [Watts]

Output [Watts]

Output [Watts]

500

443

483

553

600

532

579

663

700

620

676

774

800

709

772

884

900

797

869

995

1000

886

965

1105

1100

975

1062

1216

1200

1063

1158

1326

1300

1152

1255

1437

1400

1240

1351

1547

1600

1418

1544

1768

1800

1595

1737

1989

2000

1772

1930

2210

2200

1949

2123

2431

2400

2126

2316

2652

Watts/m 70/55/20

717

781

889

Watts/m 55/45/20

456

497

558

Water content l/m

4,44

4,99

6,12

Weight kg/m

26,15

29,29

33,55

Radiator exponent n



1,30

1,30

1,34

Heating output in compliance with DIN EN 442, and ÖNORM EN 442, at 75/65/20° C

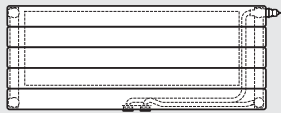
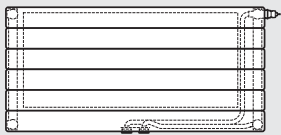
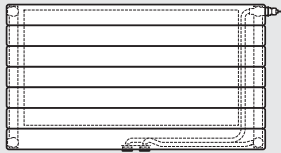
Side panels and top cover are included in the heat output specifications

	Overall depth 93 mm					
	Overall height [mm]	358	430	502		
Model	VHV-M 20	VHV-M 20	VHV-M 20			
	Overall length [mm]	Output [Watts]	Output [Watts]	Output [Watts]		
500	327	379	430			
600	392	454	515			
700	458	530	601			
800	523	606	687			
900	589	681	773			
1000	654	757	859			
1100	719	833	945			
1200	785	908	1031			
1300	850	984	1117			
1400	916	1060	1203			
1600	1046	1211	1374			
1800	1177	1363	1546			
2000	1308	1514	1718			
2200	1439	1665	1890			
2400	1570	1817	2062			
Watts/m 70/55/20	533	617	699			
Watts/m 55/45/20	344	397	450			
Water content l/m	5,55	6,66	7,77			
Weight kg/m	21,29	25,30	29,31			
Radiator exponent n	1,26	1,26	1,27			

Heating output in compliance with DIN EN 442, and ÖNORM EN 442, at 75/65/20° C

Side panels and top cover are included in the heat output specifications



Overall depth
93 mm

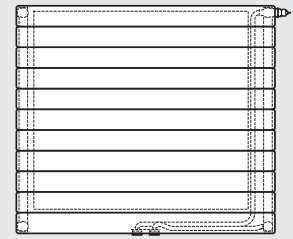
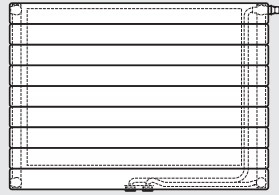
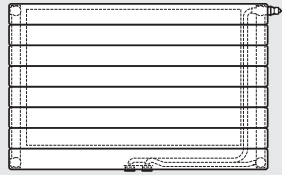

Overall height
[mm]

574

646

790

Model

VHV-M 20

VHV-M 20

VHV-M 20



Overall length
[mm]

Output
[Watts]

Output
[Watts]

Output
[Watts]

500

480

532

636

600

576

638

763

700

672

744

890

800

768

850

1017

900

864

957

1144

1000

960

1063

1271

1100

1056

1169

1398

1200

1152

1276

1525

1300

1248

1382

1652

1400

1344

1488

1779

1600

1536

1701

2034

1800

1728

1913

2288

2000

1920

2126

2542

2200

2112

2339

2796

2400

2304

2551

3050

Watts/m 70/55/20

781

864

1032

Watts/m 55/45/20

501

554

660

Water content l/m

8,88

9,99

12,22

Weight kg/m

33,31

37,32

45,33

Radiator exponent n

1,27

1,28

1,28

Heating output in compliance with DIN EN 442, and ÖNORM EN 442, at 75/65/20° C

Side panels and top cover are included in the heat output specifications



Overall depth
93 mm

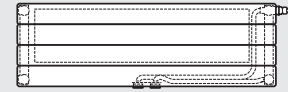
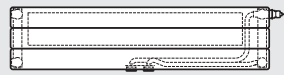

Overall height
[mm]

214

286

Model

VHV-M 22

VHV-M 22



Overall length
[mm]

Output
[Watts]

Output
[Watts]

500

385

469

600

461

563

700

538

657

800

615

750

900

692

844

1000

769

938

1100

846

1032

1200

923

1126

1300

1000

1219

1400

1077

1313

1600

1230

1501

1800

1384

1688

2000

1538

1876

2200

1692

2064

2400

1846

2251

Watts/m 70/55/20

621

756

Watts/m 55/45/20

393

477

Water content l/m

3,34

4,44

Weight kg/m

20,59

27,23

Radiator exponent n

1,31

1,32

Heating output in compliance with DIN EN 442, and ÖNORM EN 442, at 75/65/20° C

Side panels and top cover are included in the heat output specifications



Overall depth 93 mm

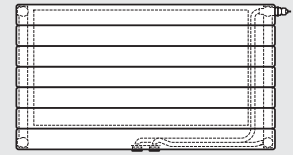
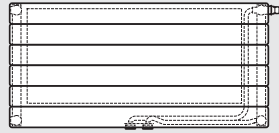
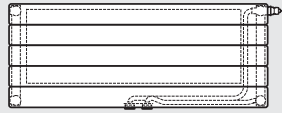

Overall height [mm]

358

430

502

Model

VHV-M 22

VHV-M 22

VHV-M 22



Overall length [mm]

Output [Watts]

Output [Watts]

Output [Watts]

500

550

634

703

600

660

761

843

700

770

888

984

800

880

1014

1124

900

990

1141

1265

1000

1100

1268

1405

1100

1210

1395

1546

1200

1320

1522

1686

1300

1430

1648

1827

1400

1540

1775

1967

1600

1760

2029

2248

1800

1980

2282

2529

2000

2200

2536

2810

2200

2420

2790

3091

2400

2640

3043

3372

Watts/m 70/55/20

885

1021

1130

Watts/m 55/45/20

555

642

708

Water content l/m

5,55

6,66

7,77

Weight kg/m

30,89

36,93

42,96

Radiator exponent n







1,34

1,33

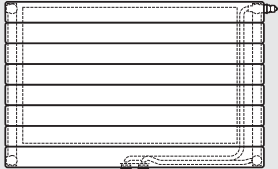
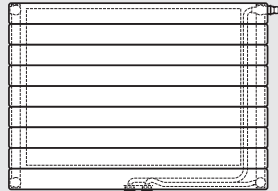
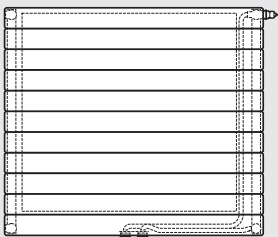
1,34

Heating output in compliance with DIN EN 442, and ÖNORM EN 442, at 75/65/20° C

Side panels and top cover are included in the heat output specifications

									
Overall depth 93 mm									
	Overall height [mm]	574	646	790					
Model	VHV-M 22			VHV-M 22			VHV-M 22		
	Overall length [mm]	Output [Watts]	Output [Watts]	Output [Watts]					
500	767	827	943						
600	920	992	1132						
700	1074	1158	1320						
800	1227	1323	1509						
900	1381	1489	1697						
1000	1534	1654	1886						
1100	1687	1819	2075						
1200	1841	1985	2263						
1300	1994	2150	2452						
1400	2148	2316	2640						
1600	2454	2646	3018						
1800	2761	2977	3395						
2000	3068	3308	3772						
2200	3375	3639	4149						
2400	3682	3970	4526						
Watts/m 70/55/20	1232			1326			1500		
Watts/m 55/45/20	769			825			919		
Water content l/m	8,88			9,99			12,22		
Weight kg/m	49,01			55,05			63,06		
Radiator exponent n	1,35			1,36			1,41		

Heating output in compliance with DIN EN 442, and ÖNORM EN 442, at 75/65/20° C

Side panels and top cover are included in the heat output specifications



Overall depth
175 mm

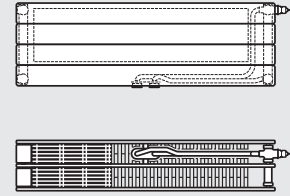
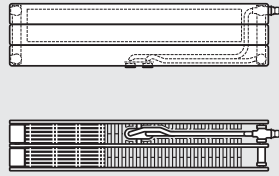
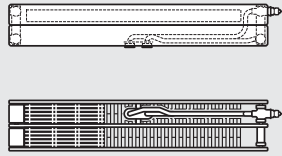

Overall height
[mm]

142

214

286

Model

VHV-M 34

VHV-M 34

VHV-M 34



Overall length
[mm]

Output
[Watts]

Output
[Watts]

Output
[Watts]

500

477

679

808

600

572

814

970

700

667

950

1131

800

762

1086

1293

900

858

1221

1454

1000

953

1357

1616

1100

1048

1493

1778

1200

1144

1628

1939

1300

1239

1764

2101

1400

1334

1900

2262

1600

1525

2171

2586

1800

1715

2443

2909

2000

1906

2714

3232

2200

2097

2985

3555

2400

2287

3257

3878

Watts/m 70/55/20

773

1094

1296

Watts/m 55/45/20

493

690

808

Water content l/m

3,33

4,99

6,66

Weight kg/m

23,93

35,18

46,42

Radiator exponent n



1,29

1,32

1,36

Heating output in compliance with DIN EN 442, and ÖNORM EN 442, at 75/65/20° C

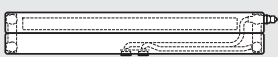
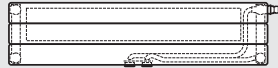
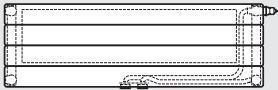
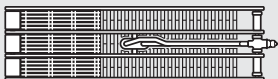
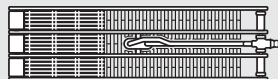
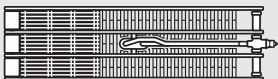
Side panels and top cover are included in the heat output specifications

									
Overall depth 257 mm									
	Overall height [mm]			Overall height [mm]			Overall height [mm]		
	142			214			286		
Model	VHV-M 46			VHV-M 46			VHV-M 46		
	Overall length [mm]			Overall length [mm]			Overall length [mm]		
	Output [Watts]			Output [Watts]			Output [Watts]		
500	717			948			1179		
600	860			1137			1414		
700	1003			1327			1650		
800	1146			1516			1886		
900	1290			1706			2121		
1000	1433			1895			2357		
1100	1576			2085			2593		
1200	1720			2274			2828		
1300	1863			2464			3064		
1400	2006			2653			3300		
1600	2293			3032			3771		
1800	2579			3411			4243		
2000	2866			3790			4714		
2200	3153			4169			5185		
2400	3439			4548			5657		
Watts/m 70/55/20	1160			1525			1885		
Watts/m 55/45/20	738			957			1168		
Water content l/m	4,53			6,79			9,06		
Weight kg/m	33,89			49,76			65,62		
Radiator exponent n	1,30			1,34			1,37		

Heating output in compliance with DIN EN 442, and ÖNORM EN 442, at 75/65/20° C

Side panels and top cover are included in the heat output specifications



Overall depth
68 mm

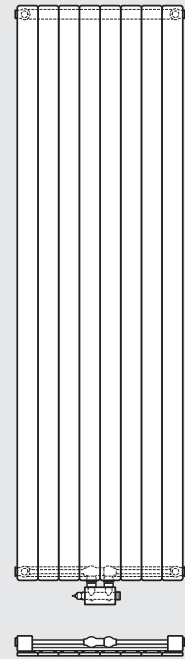
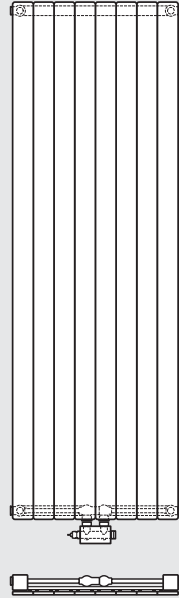
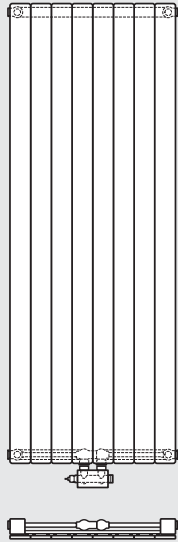

Overall height
[mm]

1600

1800

2000

Model

VSV-M 10

VSV-M 10

VSV-M 10



Overall length
[mm]

Output
[Watts]

Output
[Watts]

Output
[Watts]

214

372

424

478

286

497

566

638

358

622

708

799

430

747

851

960

502

872

993

1120

574

998

1136

1281

646

1123

1278

1442

718

1248

1421

1603

790

1373

1563

1763

862

1498

1706

1924

Watts/m 70/55/20

1384

1577

1781

Watts/m 55/45/20

850

968

1097

Water content l/m

11,37

12,47

13,85

Weight kg/m

44,45

49,60

54,75

Radiator exponent n

1,40

1,40

1,39

Heating output in compliance with DIN EN 442, and ÖNORM EN 442, at 75/65/20° C

Side panels and top cover are included in the heat output specifications



Overall depth
68 mm

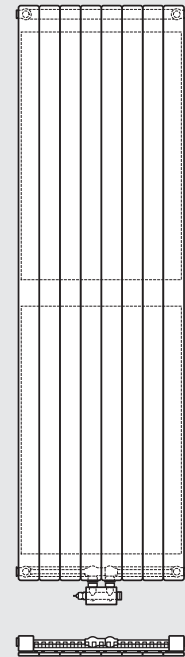
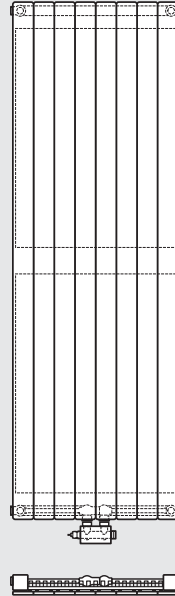
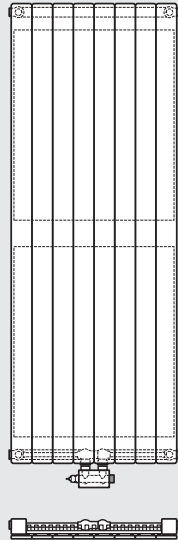

Overall height
[mm]

1600

1800

2000

Model

VSV-M 11

VSV-M 11

VSV-M 11



Overall length
[mm]

Output
[Watts]

Output
[Watts]

Output
[Watts]

214

424

473

524

286

566

632

701

358

708

791

877

430

851

950

1054

502

993

1109

1230

574

1136

1268

1406

646

1278

1427

1583

718

1421

1586

1759

790

1563

1745

1936

862

1706

1904

2112

Watts/m 70/55/20

1584

1768

1964

Watts/m 55/45/20

983

1097

1223

Water content l/m

11,37

12,47

13,85

Weight kg/m

63,39

68,53

73,69

Radiator exponent n

1,37

1,37

1,36

Heating output in compliance with DIN EN 442, and ÖNORM EN 442, at 75/65/20° C

Side panels and top cover are included in the heat output specifications



Overall depth
93 mm

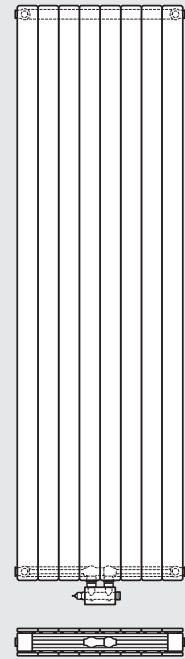
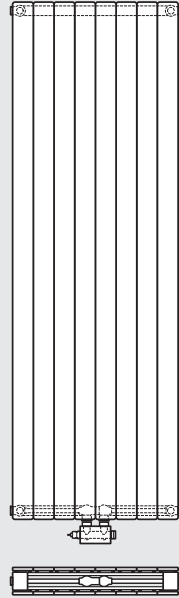
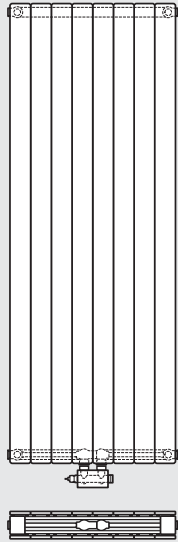

Overall height
[mm]

1600

1800

2000

Model

VSV-M 20

VSV-M 20

VSV-M 20



Overall length
[mm]

Output
[Watts]

Output
[Watts]

Output
[Watts]

214

627

706

786

286

839

944

1050

358

1050

1182

1315

430

1261

1419

1579

502

1472

1657

1843

574

1683

1895

2108

646

1894

2132

2372

718

2105

2370

2636

790

2316

2608

2901

862

2527

2845

3165

Watts/m 70/55/20

2332

2629

2929

Watts/m 55/45/20

1427

1615

1805

Water content l/m

22,74

24,34

27,71

Weight kg/m

85,44

95,46

105,48

Radiator exponent n

1,41

1,40

1,39

Heating output in compliance with DIN EN 442, and ÖNORM EN 442, at 75/65/20° C

Side panels and top cover are included in the heat output specifications



Overall depth
93 mm

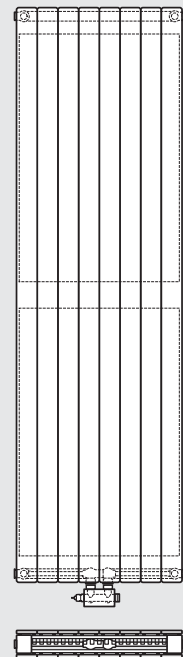
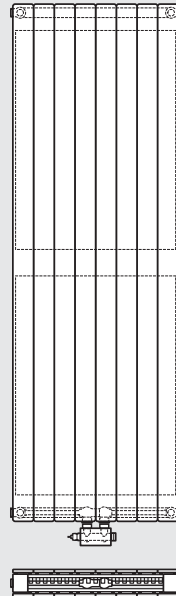
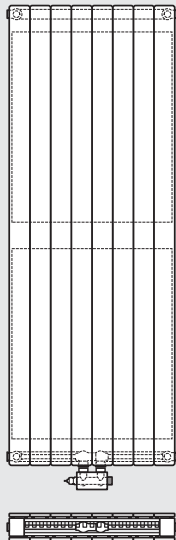

Overall height
[mm]

1600

1800

2000

Model

VSV-M 21

VSV-M 21

VSV-M 21



Overall length
[mm]

Output
[Watts]

Output
[Watts]

Output
[Watts]

214

681

768

859

286

911

1026

1147

358

1140

1285

1436

430

1369

1543

1725

502

1598

1801

2014

574

1828

2060

2303

646

2057

2318

2592

718

2286

2576

2881

790

2515

2835

3169

862

2745

3093

3458

Watts/m 70/55/20

2536

2857

3206

Watts/m 55/45/20

1557

1755

1983

Water content l/m

22,74

24,34

27,71

Weight kg/m

104,37

114,39

124,42

Radiator exponent n

1,40

1,40

1,38

Convectors & heating panels

KONTEC convectors and horizontal heating panels are radiators in fully welded designs, with either 1 to 5 layers of steel rectangular water-flow pipes arranged one-behind-the-other (for convectors), or 1 or 2 such layers (for horizontal heating panels). In each layer, the convectors have between one and four pipes arranged one-above-the-other; the horizontal heating panels have from 5 to 11 pipes.

KONTEC vertical heating panels consist of 1 or 2 layers of steel rectangular water-flow pipes, arranged one-behind-the-other, with 2 to 12 steel pipes, arranged side-by-side.

A 2 mm space between the heating pipes guarantees additional resistance to corrosion. **KONTEC** convectors and horizontal heating panels come with side panels and top covers; **KONTEC**

vertical heating panels come with side panels. **KONTEC** heating panels are delivered with welded mounting brackets.

All **KONTEC** convectors and heating panels are also delivered with factory-sealed drain plugs and pivotable vent plugs. (Exception: bottom-opposite-end connection models come with a dummy plug instead of the drain plug.)

Standard design: rectangular steel pipes, 70 x 11 x 1.5 mm
High-pressure design: rectangular steel pipes, 70 x 11 x 2.0 mm

WVO-design: **KONTEC** convectors are also available with a welded heat reflector (no water-flow).

Convector dimensions:

Overall lengths: between 500 mm and 1400 mm (at increments of 100 mm),
 and between 1600 mm and 4000 mm (at increments of 200 mm)
 Overall heights: 70 mm, 142 mm, 214 mm and 286 mm

Horizontal heating panel dimensions:

Overall lengths: between 500 mm and 1400 mm (at increments of 100 mm), and
 between 1600 mm and 4000 mm (at increments of 200 mm)
 Overall heights: 358 mm, 430 mm, 502 mm, 574 mm, 646 mm and 790 mm

Vertical heating panel dimensions:

Overall lengths: between 142 mm and 862 mm (at increments of 72 mm)
 Overall heights: between 1600 mm and 2200 mm (at increments of 200 mm)

Coatings:

1. Undercoat: electrophoretic, using water-soluble paints, conforming to DIN 55900 part 1, stoved at 165° C;
2. Finish: electrostatic powder coating, conforming to DIN 55900 part 2, in a state-of-the-art facility. (On request, and at a supplementary charge, a range of RAL and sanitary ware colours can be offered.) This particularly robust coating is stoved at an object temperature of 180° C.

- Packaging:**
1. Cardboard packaging
 2. Edge protection
 3. Shrink foil

Connections:
 2 x internal thread G 1/2", welded-in for supply and return. Vent and drain plugs (or dummy plug) are factory sealed and are fitted according to the customer's specifications.

5 bar max. **Maximum positive operating pressure**
 Standard design: **5 bar**

8 bar max. **Maximum positive operating pressure:**
 High-pressure design (supplementary charge): **8 bar**

max. **Maximum operating temperature: 110 °C**

Quality certificates

Strong brands of the highest quality

VOGEL&NOOT offers its customers strong brands that meet highest quality standards. All the production sites' production processes are certified according to ISO. The quality and performance specifications of the convectors and heating panels have been verified by recognised European institutions.

The standards that the quality certificates require us to maintain give you security, the best heating performance and premium product quality. For the **VOGEL&NOOT** warranty conditions, please see the installation sheet, which is enclosed with each **VONARIS/KONTEC** convector or heating panel.



Horizontal design, KK models

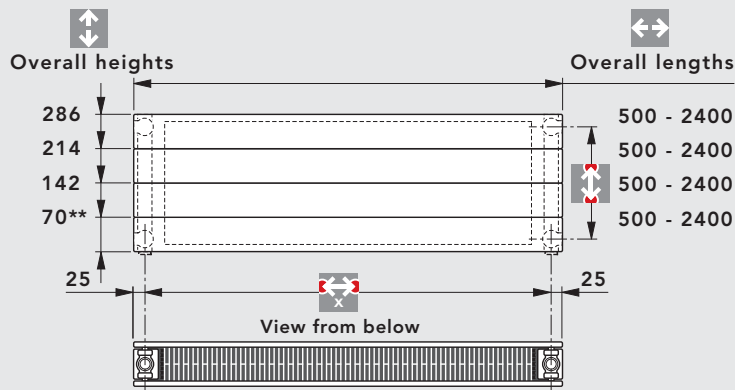
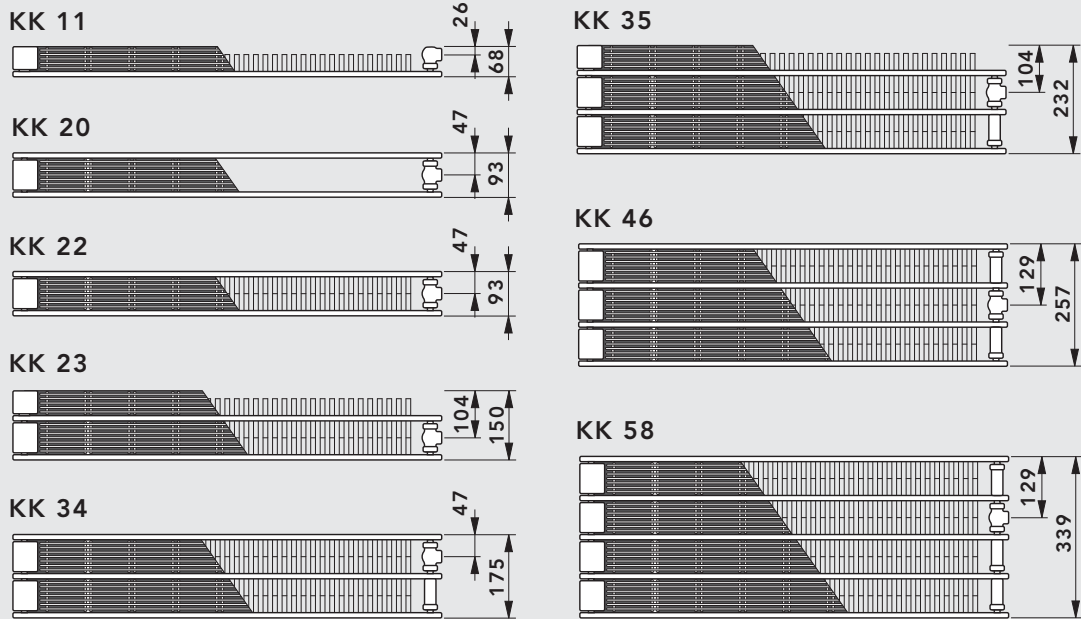

*Connection vertically from below:

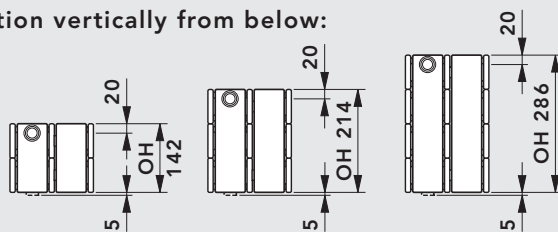

Note: with an OH of 70 mm, vertical connection from below is not available!

Side connections:

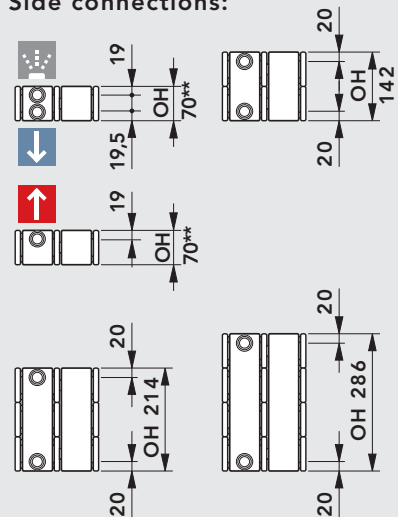

* Models with an overall height of 142, 214 or 286 mm can also be delivered with supply and return connections vertically from below (as special designs and with a supplementary charge).

** Only available with top-bottom, opposite-ends, side-connection.

Overall height [mm]	↕	70**	142	214	286
Boss spacing NA [mm]	↕	32	102	174	246
Boss spacing NAS* [mm]	↕	Overall length - 50 mm			

Schematic diagram

Model	KK 11	KK 20	KK 22	KK 23	KK 34	KK 35	KK 46	KK 58								
Overall height	-	-	-	142	70	142	70	142	70	142	70	142	70	142	70	142
↕																
[mm]	214	286	214	286	214	286	214	286	214	286	214	286	214	286	214	286
Overall length	500 - 2400 mm (for special overall lengths see output charts), model 58 up to 2200 mm															
↔																
[mm]																
Increments	100 mm (for an overall length of 1400 mm and greater: 200 mm)															

The KK-S models

With their factory-welded heat reflector (no water-flow), the WVO designs return a major part of the otherwise lost heat to the room. They do so by means of convection between radiator and heat reflector.

Model overview / connection dimensions: KK-S models, horizontal design

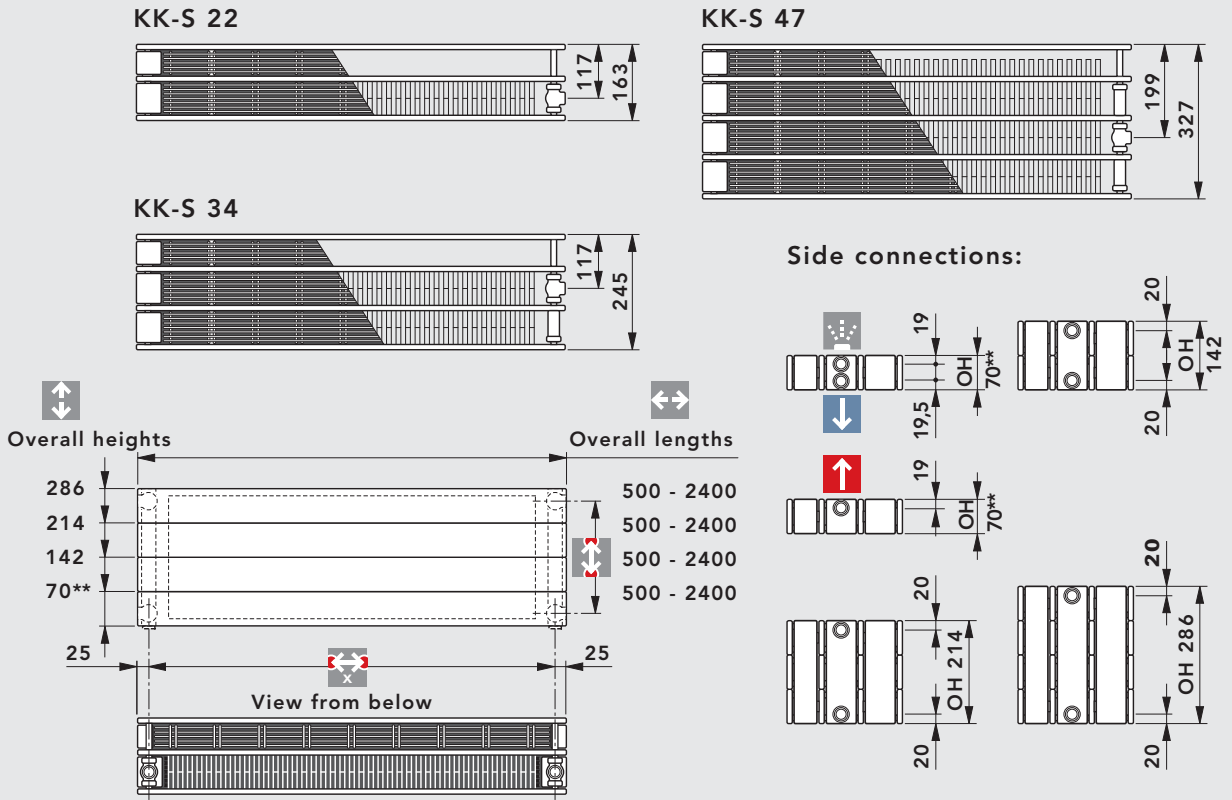

*Connection vertically from below:

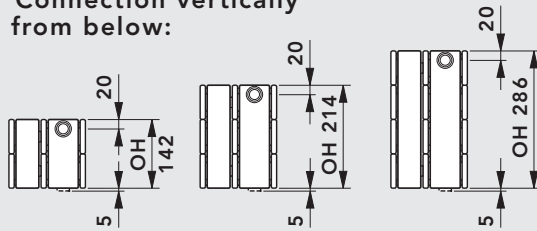

* Models with an overall height of 142, 214 or 286 mm can also be delivered with supply and return connections vertically from below (as special designs and with a supplementary charge).

** Only available with top-bottom, opposite-ends, side-connection.

Note: with an OH of 70 mm, vertical connection from below is not available!

Overall height [mm]	↕	70**	142	214	286	Schematic diagram
Boss spacing NA [mm]	↕	32	102	174	246	
Boss spacing NAS* [mm]	↕	Overall length - 50 mm				

Model	KK-S 22				KK-S 34				KK-S 47			
Overall height [mm]	70	142	214	286	70	142	214	286	70	142	214	286
Overall length [mm]	500 – 2400 mm (for special overall lengths see output charts)											
Increments	100 mm (for an overall length of 1400 mm and greater: 200 mm)											

KH models horizontal design

KH 10

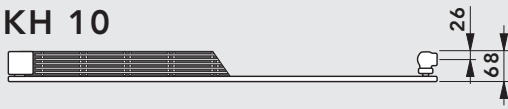

KH 20

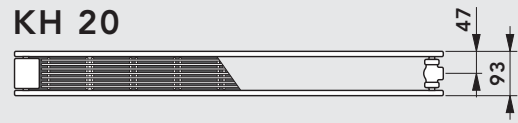

KH 11

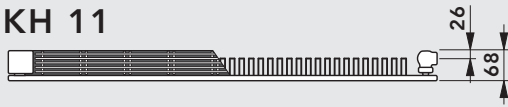

KH 22

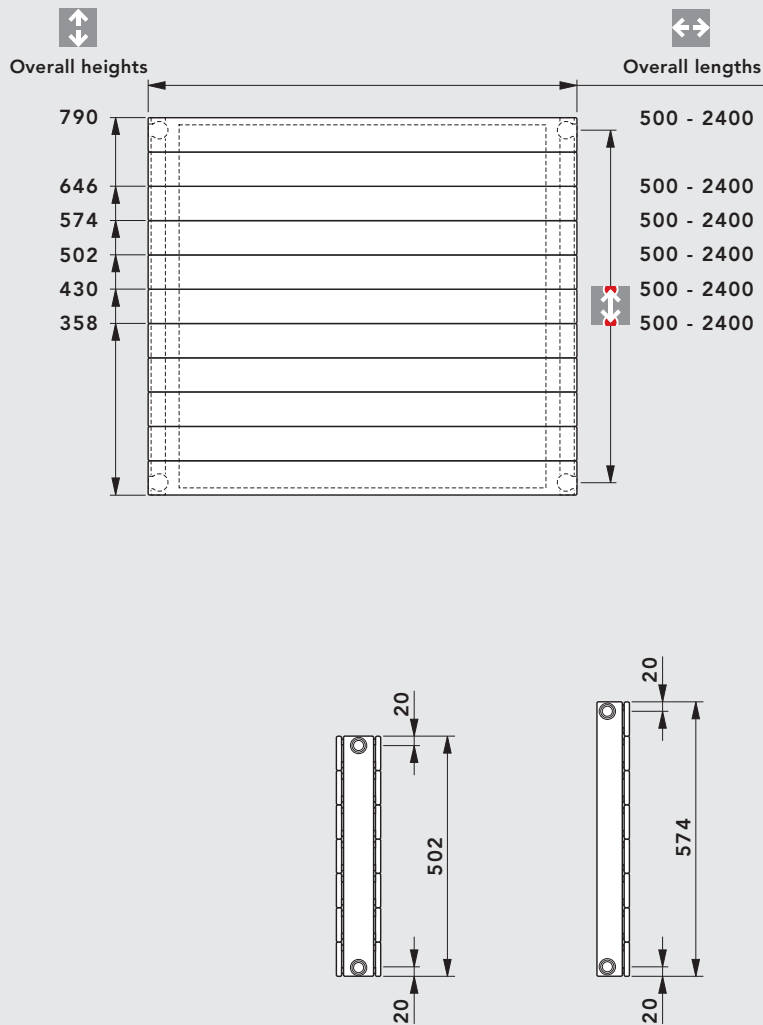
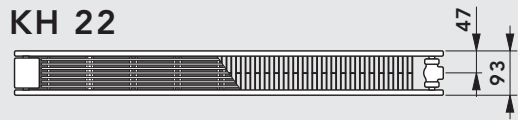

Overall height [mm] 358 430 502 574 646 790 Schematic diagram

Boss spacing NA [mm] 318 390 462 534 606 750

Model	KH 10			KH 11			KH 20			KH 22		
Overall height [mm]	358	430	502	358	430	502	358	430	502	358	430	502
	574	646	790	574	646	790	574	646	790	574	646	790
Overall length [mm]	500 – 2400 mm (for special overall lengths see output charts)											
Increments	100 mm (for an overall length of 1400 mm and greater: 200 mm)											

KS models vertical design

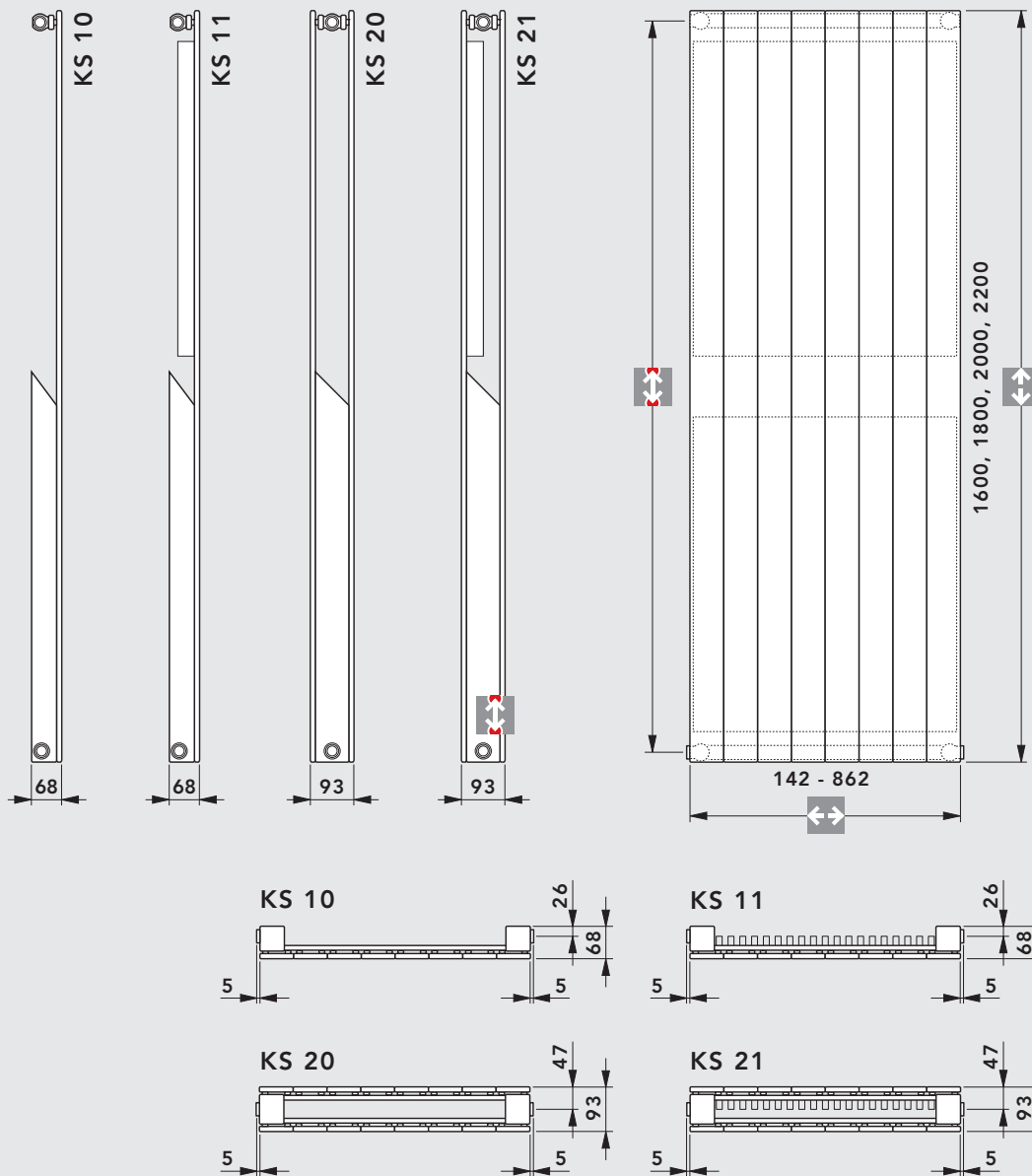

Overall height [mm]	↕	1600	1800	2000	2200	Schematic diagram
Boss spacing NA [mm]	↕	1550	1750	1950	2150	

Model	KS 10		KS 11		KS 20		KS 21	
Overall height ↕ [mm]	1600	1800	1600	1800	1600	1800	1600	1800
	2000	2200	2000	2200	2000	2200	2000	2200
Overall length ↔ [mm]	142 - 862 mm							
Increments	72 mm							

Convector models KK / KK-S

Model description

KK-S 34 / 214 / 2000

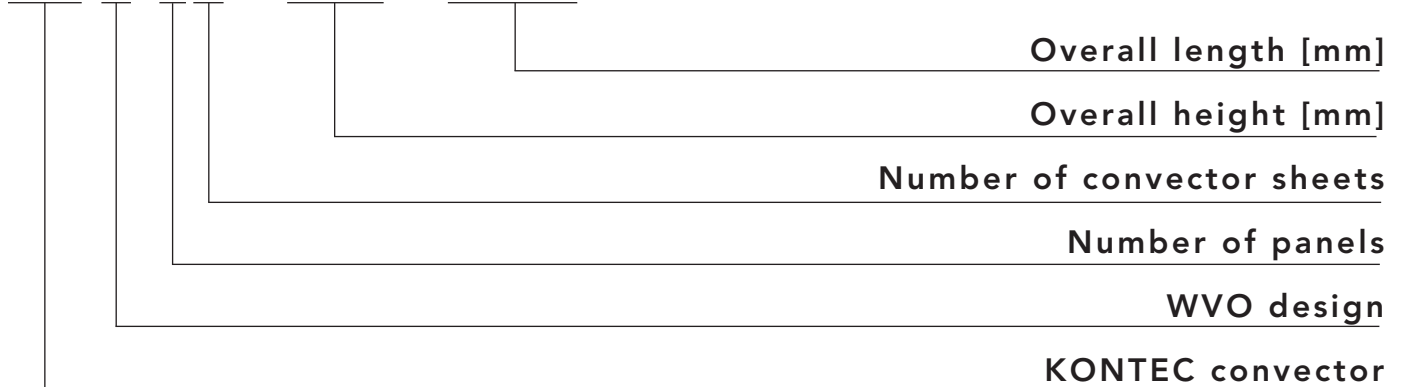

For each individual horizontal design order, the following data must be specified:

- Model (KK, KK-S)
- Overall height [mm]
- Overall length [mm]
- Specification of the RAL or Sanitary-Ware Colour number
- Connections and their positioning (**Note:** with an OH of 70 mm, only a top-bottom, opposite-ends, side-connection is possible!)
- Positive operating pressure (N(normal) standard design 5 bar / H ...high-pressure design 8 bar)
- Without brackets = 0 / with brackets = 1 (By default the **KONTEC** convectors are delivered without brackets).

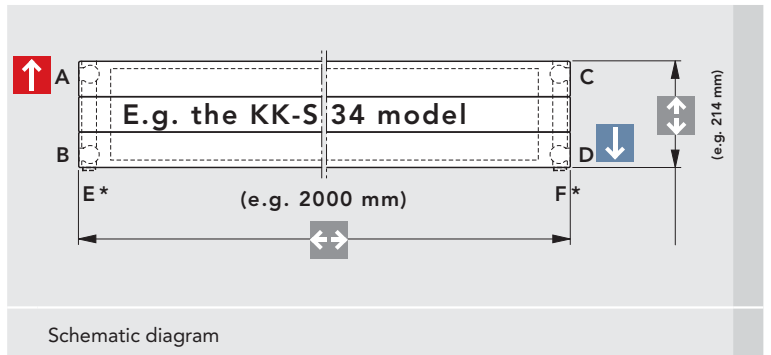

Note: For technical production reasons, the required connections must be accurately specified, using the following codes for the appropriate connection pictograms:

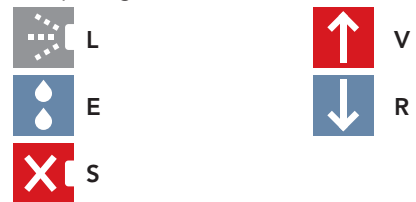

Order example:

1 **KONTEC** convector in WVO design, KK-S 34 model, overall height 214 mm, overall length 2000 mm, colour RAL 3000, with 2 stand consoles SK 14 for finished floors, operating pressure 8 bar (high pressure design).

Top-bottom, opposite-ends, side-connection: A / V(top left connection, for supply)
 B / E(bottom left connection for drain)
 C / L(top right connection for vent)
 D / R(bottom right connection for return)

*As a special design and for a supplementary charge the supply and return connections can also be delivered in a vertical, from below design (see **E*** and **F***). This does not apply for OH of 70 mm.

Example of an order form:

Pos./ Room	Number	Model	Overall height [mm]	Overall length [mm]	Colour	Connections KS			Connections KK, KK-S and KH			Positive operating pressure	Brackets without = 0 with = 1	General accessories	
						A	B	C	D	E*	F*			Model	Number
-	1	KK-S 34	214	2000	RAL 3000	V	E	L	R	-	-	H	0	SK 14	2

Heating panel, KH model

Model description

KH 22 / 790 / 800

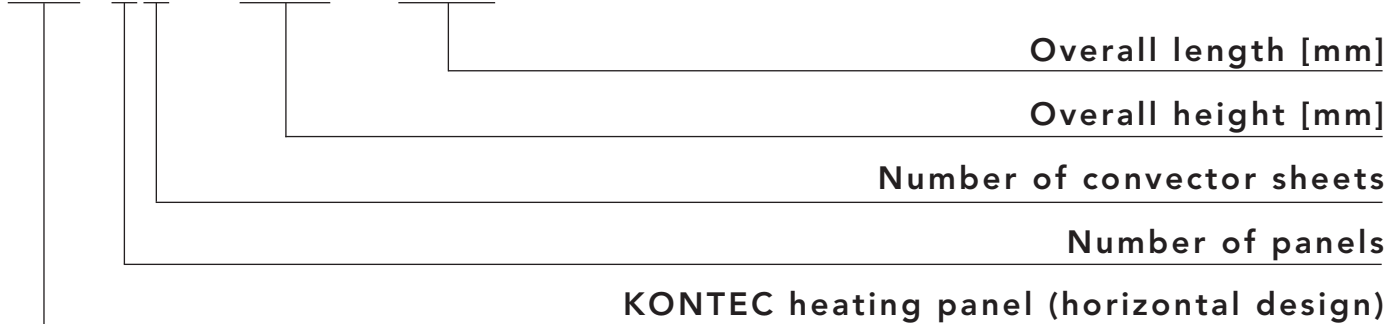

KONTEC heating panel (horizontal design)

For each individual horizontal design order, the following data must be specified:

- Model (KH)
- Overall height [mm]
- Overall length [mm]
- Specification of the RAL or Sanitary-Ware Colour number
- Connections and their positioning
- Positive operating pressure (N(normal) standard design 5 bar / H ...high-pressure design 8 bar)
- Without brackets = 0 / with brackets = 1 (By default horizontal design KONTEC heating panels are delivered with brackets).

Note: For technical production reasons, the required connections must be accurately specified, using the following codes for the appropriate connection pictograms:

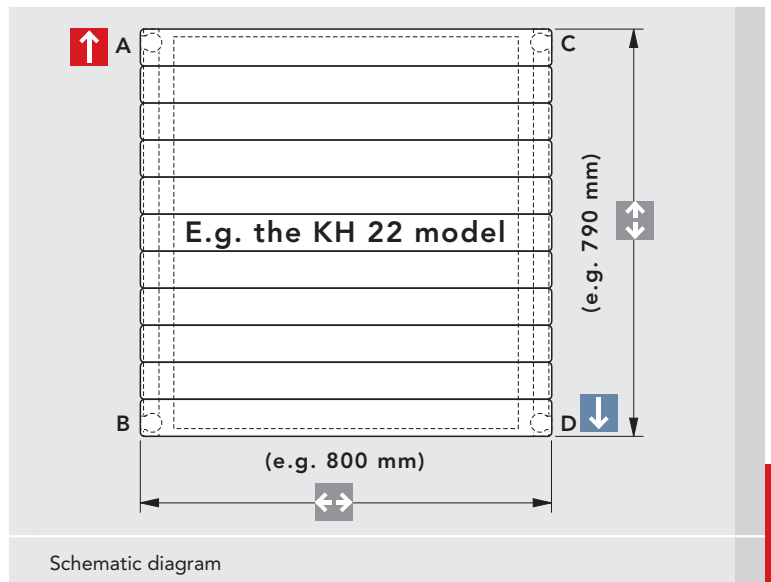

Schematic diagram

Order example:

1 KONTEC horizontal design heating panel, KH 22 model, overall height 790 mm, overall length 800 mm, colour RAL 3000, with a VONOMAT wall console (set of 2), operating pressure 5 bar (standard design).

Top-bottom, opposite-ends, side-connection: A / V(top left connection, for supply)
 B / E(bottom left connection for drain)
 C / L(top right connection for vent)
 D / R(bottom right connection for return)

Example of an order form:

Pos./ Room	Number	Model	Overall height [mm]	Overall length [mm]	Colour	Connections KS			Connections KK, KK-S and KH			Positive operating pressure	Brackets without = 0 with = 1	General accessories	
						A	B	C	D	E*	F*			Model	Number
-	1	KH 22	790	800	RAL 3000	V	E	L	R	-	-	N	1	Vonomat	1 (set of 2)

Heating panel, KS model

Model description

KS 10 / 1600 / 574

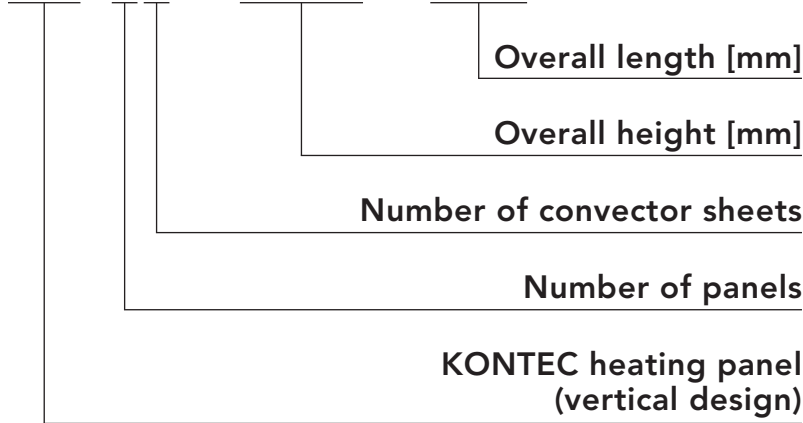

E.g. the KS 10 model

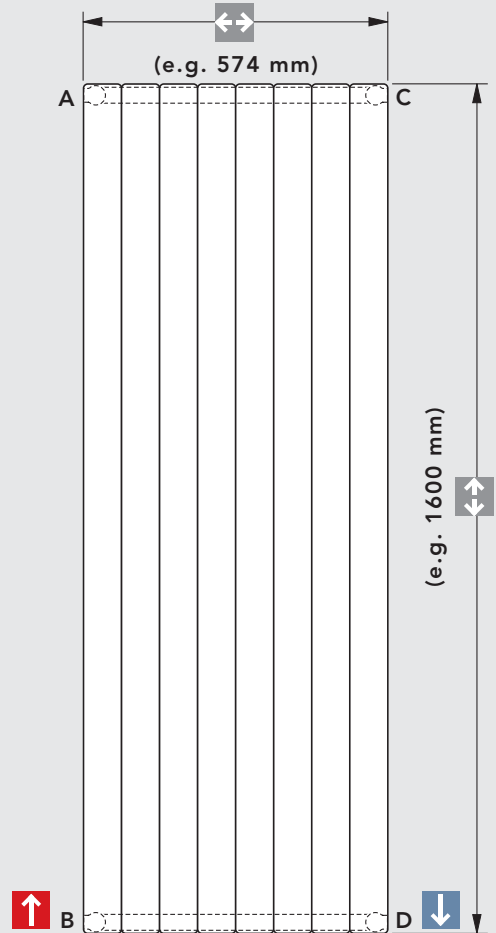

For each individual horizontal design order, the following data must be specified:

- Overall height [mm]
- Overall length [mm]
- Specification of the RAL or Sanitary-Ware Colour number
- Connections and their positioning
- Positive operating pressure (N ... (normal) standard design 5 bar / H ... high-pressure design 8 bar)
- (By default KONTEC vertical design heating panels are delivered with brackets).

Note: For technical production reasons, the required connections must be accurately specified, using the following codes for the appropriate connection pictograms:

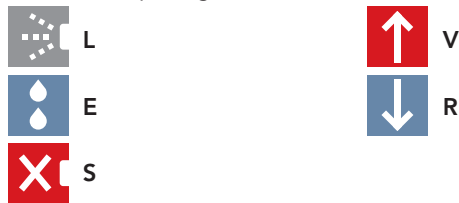

Schematic diagram

Order example:

1 KONTEC vertical design heating panel, KS 10 model, overall height 1600 mm, overall length 574 mm, colour VNF 6904, with 2 WA 11 wall mounting brackets, operating pressure 8 bar (high-pressure design).

- Top-bottom, opposite-ends, side-connection: A / V(top left connection, for supply)
B / E(bottom left connection for drain)
C / L(top right connection for vent)
D / R(bottom right connection for return)

Example of an order form:

Pos./ Room	Number	Model	Overall height [mm]	Overall length [mm]	Colour	Connections KS			Connections KK, KK-S and KH			Positive operating pressure	Brackets without = 0 with = 1	General accessories	
						A	B	C	D	E*	F*			Model	Number
-	1	KS 10	1600	574	VNF 6904	L	R	S	V	-	-	N	1	WA 11	2

KK and KK-S models

Double-pipe system

Single-sided connection, right

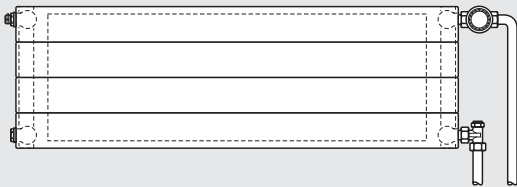

Single-sided connection, left

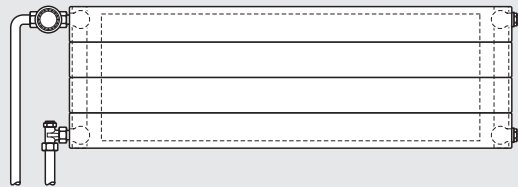

Top-bottom, opposite-end, side-connection, right-side supply

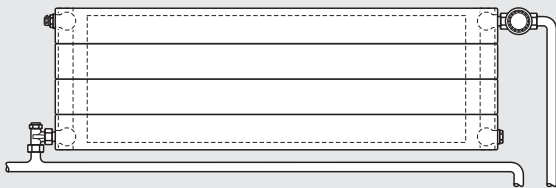

Top-bottom, opposite-end, side-connection, left-side supply

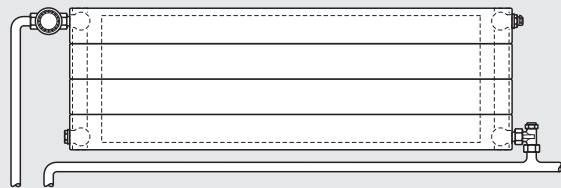

Bottom-only, opposite-end, side-connection, right-side supply
Note: reduced heat output

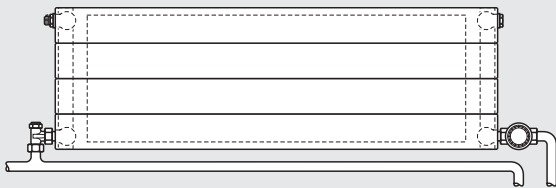

Bottom-only, opposite-end, side-connection, left-side supply
Note: reduced heat output

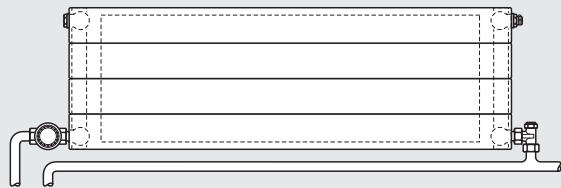

Vertical connection from below, bottom-only, opposite-end, right-side supply
Note: reduced heat output

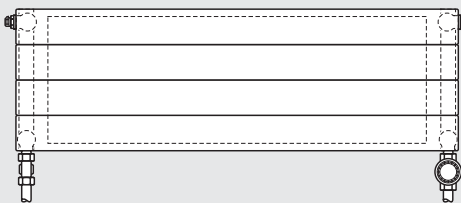

Vertical connection from below, bottom-only, opposite-end, left-side supply
Note: reduced heat output

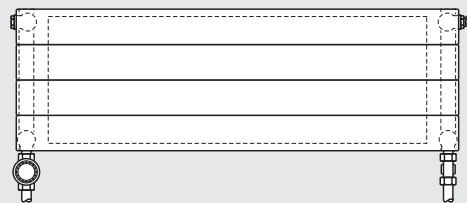

Single-pipe system

KONTEC convectors can easily be converted for use with a single-pipe system. In this case, however, 4-way valves with a by-pass pipe need to be used.

Recommendation:

For reasons of appearance the VONARIS valve design is the preferred option for this connection mode.

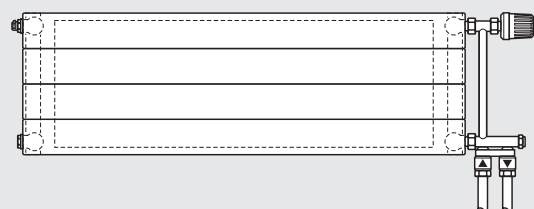

Schematic diagram

Note: when ordering your KONTEC convector (see page 76 "Description of the Ordering Process") the 4 connections must be accurately specified and assigned. This is for technical production reasons. No subsequent changes to the connections on your KONTEC convector are possible!

KH models

Double-pipe system

Single-sided connection, right

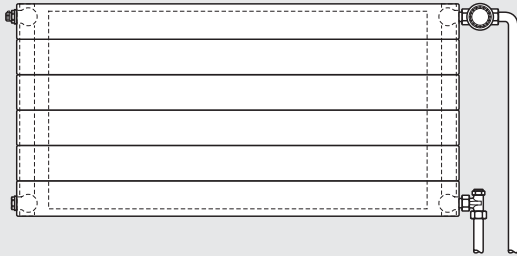

Single-sided connection, left

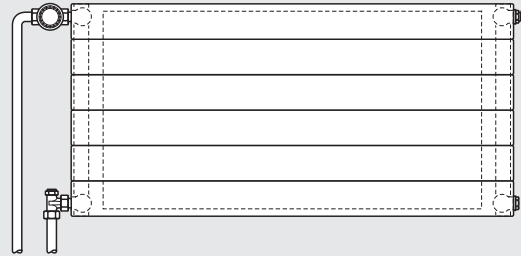

Top-bottom, opposite-end, side-connection, right-side supply

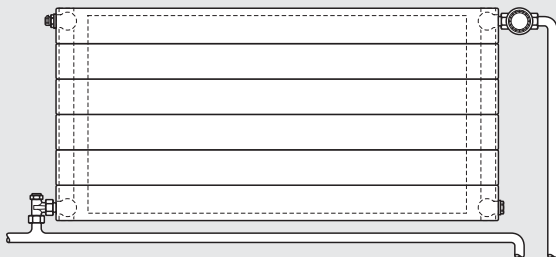

Top-bottom, opposite-end, side-connection, left-side supply

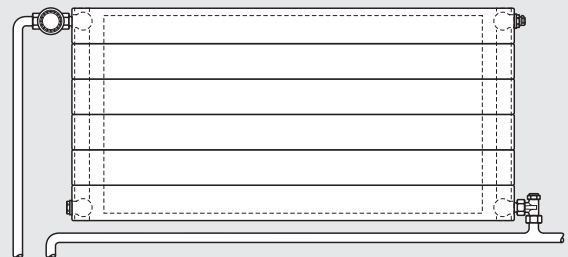

Bottom-only, opposite-end, side-connection, right-side supply
Note: reduced heat output

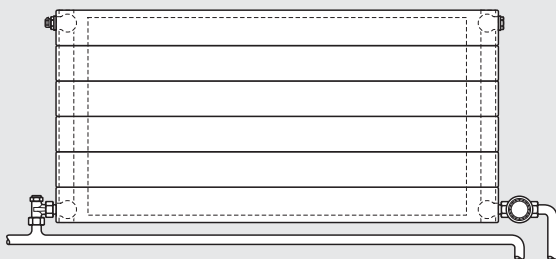

Bottom-only, opposite-end, side-connection, left-side supply
Note: reduced heat output

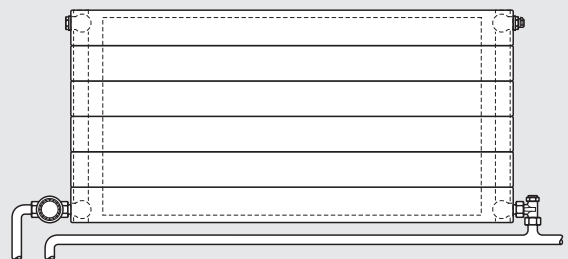

Single-pipe system

KONTEC convectors can easily be converted for use with a single-pipe system. In this case, however, 4-way valves with a by-pass pipe need to be used.

Recommendation:

For reasons of appearance the **VONARIS** valve design is the preferred option for this connection mode.

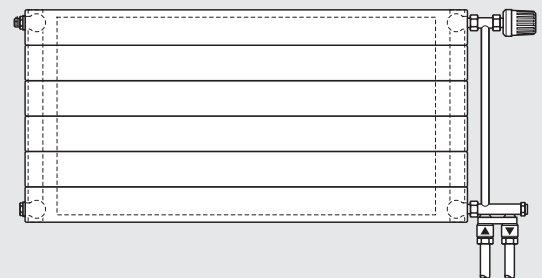

Schematic diagram

Note: when ordering your KONTEC KH model heating panels, (see page 77, "Description of the Ordering Process") the 4 connections must be accurately specified and assigned. This is for technical production reasons. No subsequent changes to the connections on your KONTEC KH model heating panels are possible!

KS models

Double-pipe system

Note: with KONTEC KS model heating panels, single-pipe connection is not possible!

Single-sided connection, right

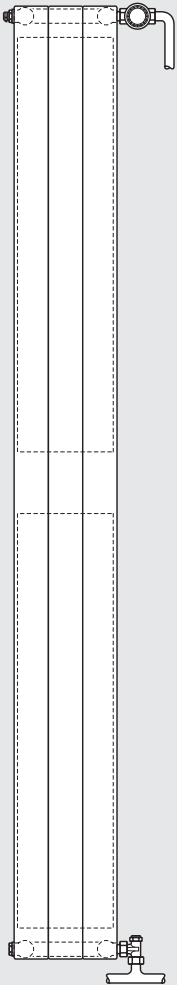

Top-bottom, opposite-end, side-connection, right-side supply

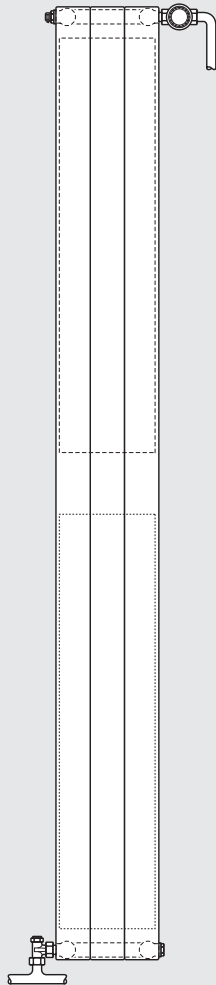

Bottom-only, opposite-end, side-connection, right-side supply

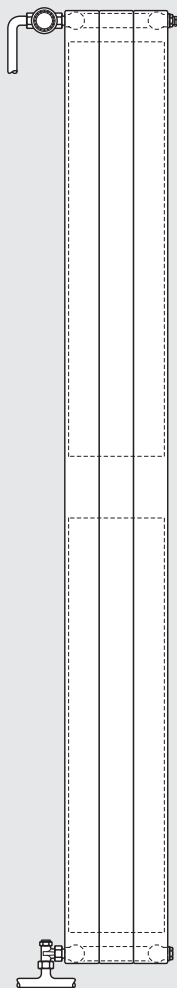
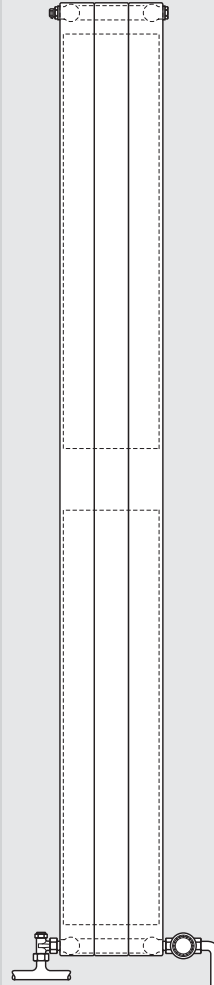

Single-sided connection, left

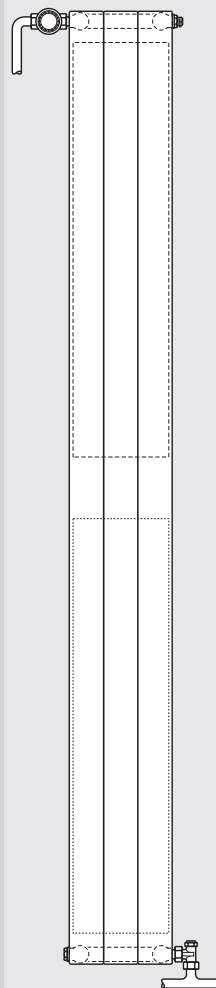

Top-bottom, opposite-end, side-connection, left-side supply

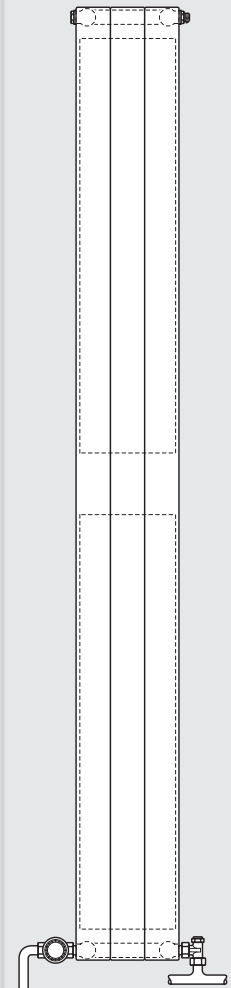

Bottom-only, opposite-end, side-connection, right-side supply

Schematic diagram

Note: when ordering your KONTEC KS model heating panel (see page 78 "Description of the Ordering Process") the 4 connections must be accurately specified and assigned. This is for technical production reasons. No subsequent changes to the connections on your KONTEC KS model heating panel are possible!

KH 20 and KH 22 models, horizontal designs**The new heat reflector**

- is available for the KH 20 (OH 358 – 574 mm) and the KH 22 (OH 358 - 646 mm) models in horizontal design
- returns a major part of the otherwise lost heat to the room, by means of convection between the KONTEC heating panel and the heat reflector.

Design:

Electrophoretic coating and finish in RAL 9016 (on request and at an extra charge, in a range of RAL and Sanitary Ware colours); delivered with 8 push-in brackets, 8 stabilising brackets, 4 Z-brackets, an installation sheet, and packaging

Note: when ordering one of the horizontal designs with a heat reflector, it is also essential to use either an **SK 22 (KH 20)** or an **SK 23 (KH 22) stand console**.

KONTEC heating panel with fitted heat reflector
 (see image to the right)

Width:	11 mm	heat reflector
Internal depth:	25 mm	between heating pipe and heat reflector
Minimum clearance*:	100 mm	between window surface and heat reflector

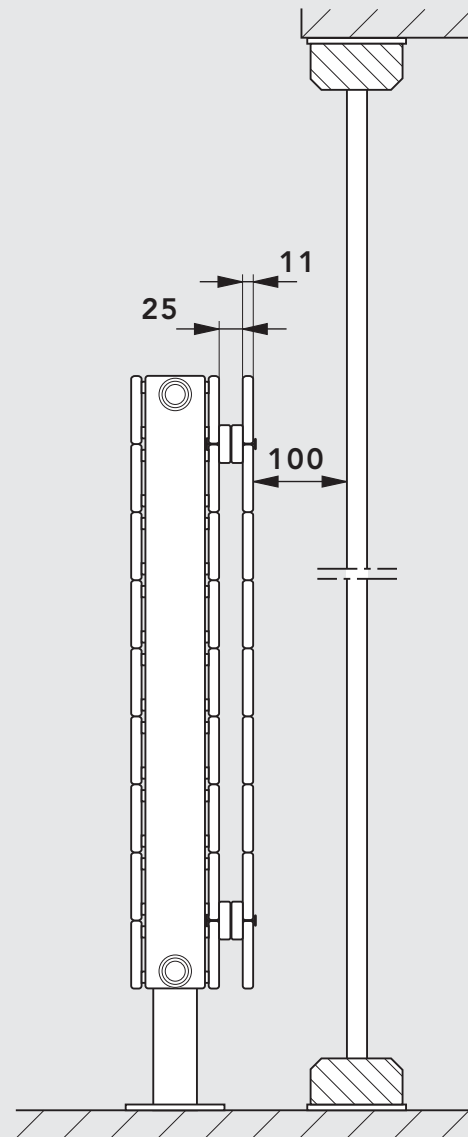

Schematic diagram

* The minimum clearance between window surface and heat reflector (100 mm) complies with the recommendations of leading window surface manufacturers.

VONOMAT wall console for KK models (convectors)

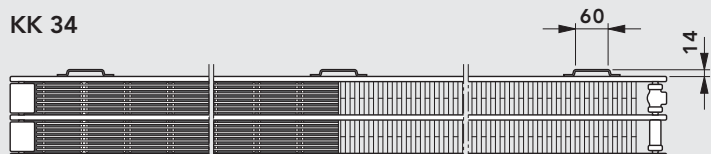
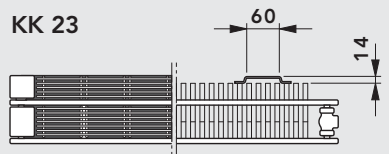
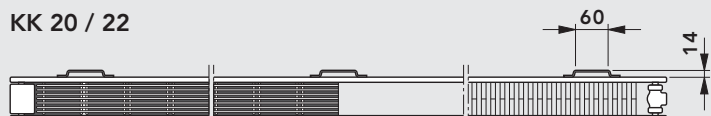
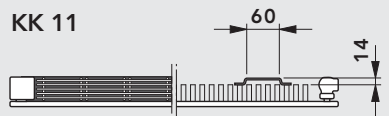
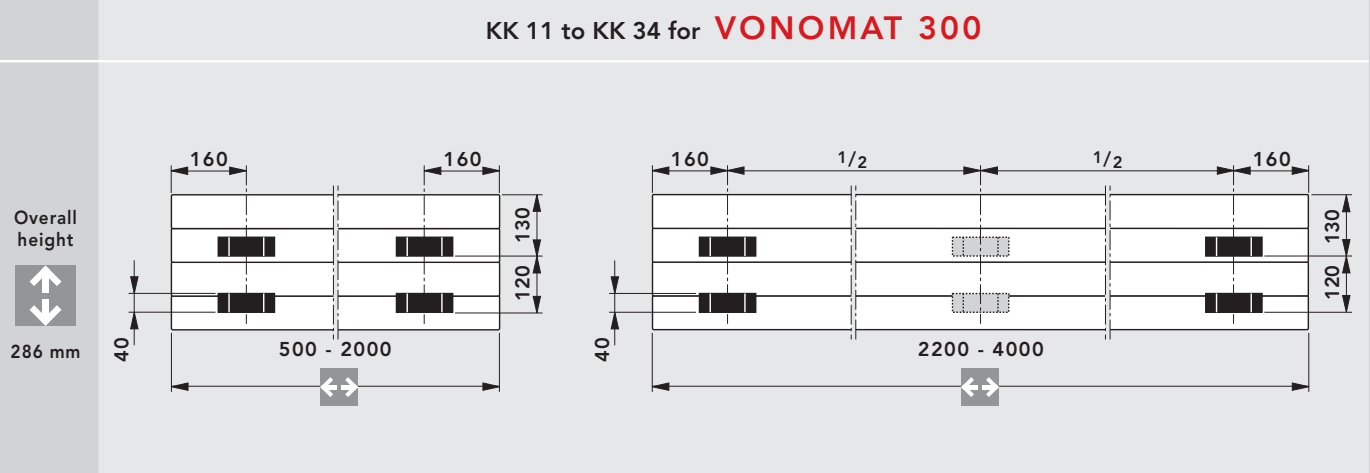
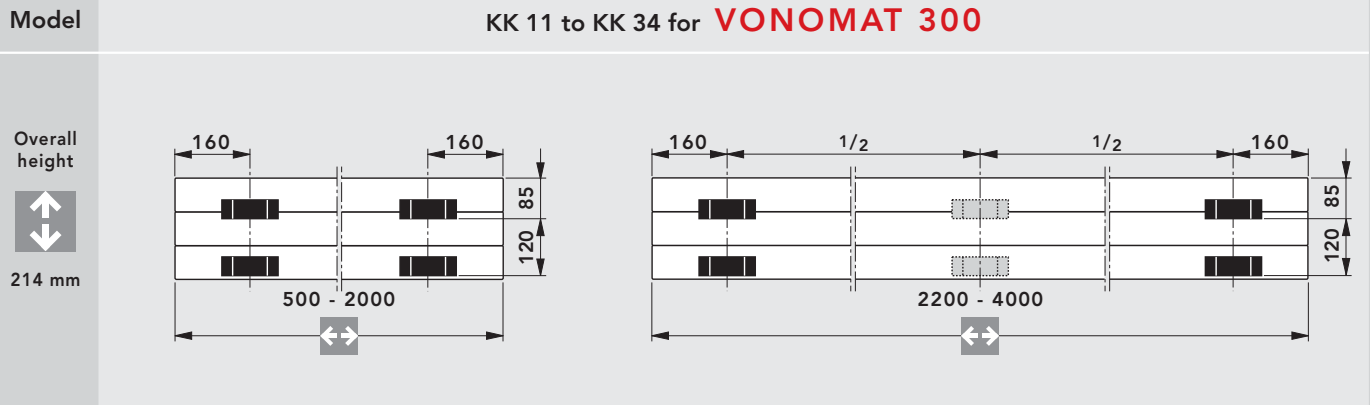

Schematic diagram

Note! By default convectors are delivered without brackets. If a **VONOMAT** wall console is used, the convector must be ordered as a special design with brackets. Convectors with an OH of 70 or 142 mm cannot be delivered with wall mounting brackets.

VONOMAT wall console for KH models (heating panels, horizontal design)

Model

KH 10 to KH 22 for **VONOMAT 400**

Overall height

from 358 mm to 502 mm

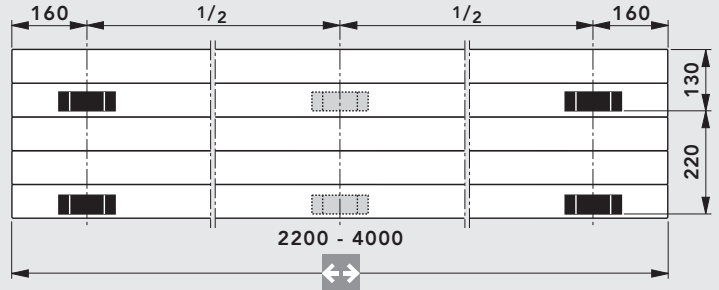
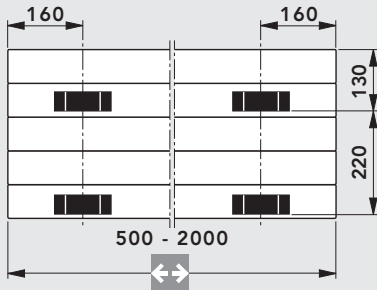

KH 10 to KH 22 for **VONOMAT 600**

Overall height

from 574 mm to 790 mm

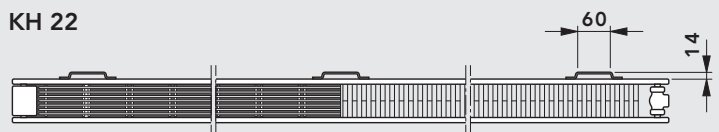
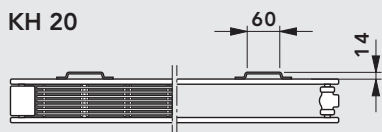
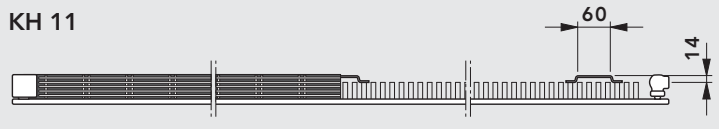
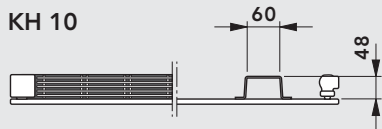
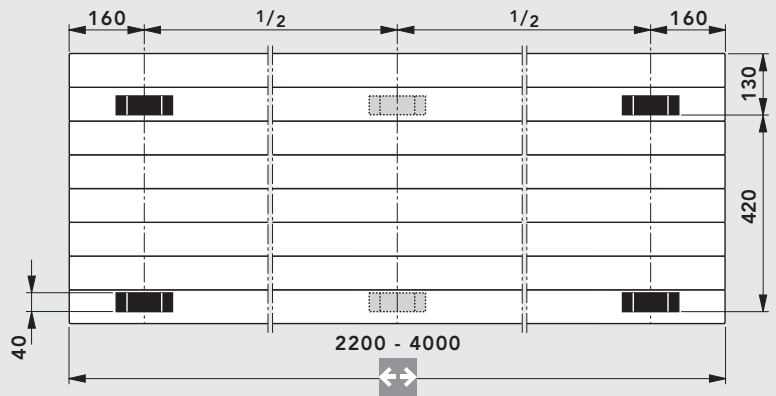
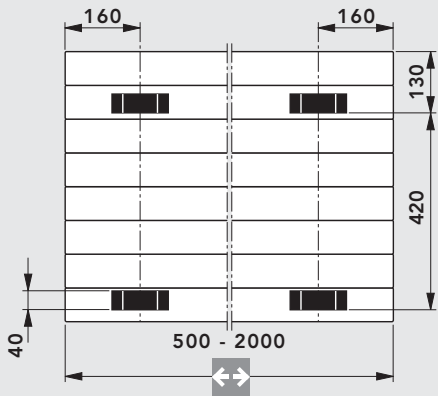

Schematic diagram

VONOMAT wall console for KK models (convectors) and KH models (heating panels, horizontal design)

KONTEC convectors and KONTEC heating panels can be installed easily, quickly and securely, whilst they are still in their wrappers. This is made possible by the **VONOMAT** wall console for KK model convectors (OH 214 and 286 mm, **with fitted brackets**) and for KH heating panels (OH 358 – 790 mm).

Wall rails for OH 214 – 790 mm

Drilling measurements for the VONOMAT 300 – 600

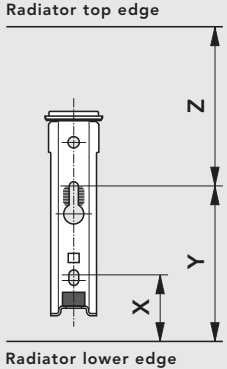
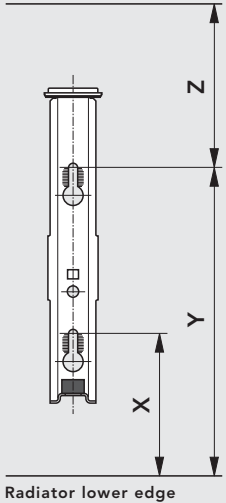
Wall rail for OH 214 / 286 mm	Overall radiator height [mm] 	Value X [mm]	Value Y [mm]	Value Z [mm]	Wall rail for BH 358 – 790 mm
 <p>Radiator top edge</p> <p>Radiator lower edge</p>	214	34	114	100	 <p>Radiator top edge</p> <p>Radiator lower edge</p>
	286	61	141	145	
	358	58	209	149	
	430	130	281	149	
	502	202	353	149	
	574	74	425	149	
	646	146	497	149	
	790	290	641	149	

Schematic diagram

The **VONOMAT** wall console with integrated connection and displacement locking features consists of:

- 2 or *3 consoles with sound-proofing,
- 2 or *3 snap-on elements,
- 2 or *3 mounting screws with dowels and safety washers

*For an overall length of 2200 mm and greater

Connection – wall clearance

Convactor and heating panel models	Overall height [mm] 	Measurement W [mm]
KK 11	214, 286	43
KK 20, KK 22, KK 34	214, 286	87
KK 23	214, 286	121,5
KH 10, KH 11	358 - 790	43
KH 20, KH 22	358 - 790	87

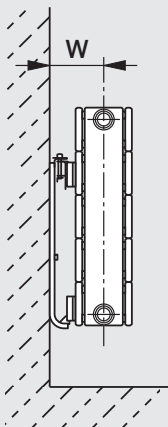

The VONOMAT wall console complies with the requirements of the TÜV Rheinland (for physical load-bearing purposes).

Schematic diagram

KS models

Overall length

 [mm]

142

214

286

358

430 - 862

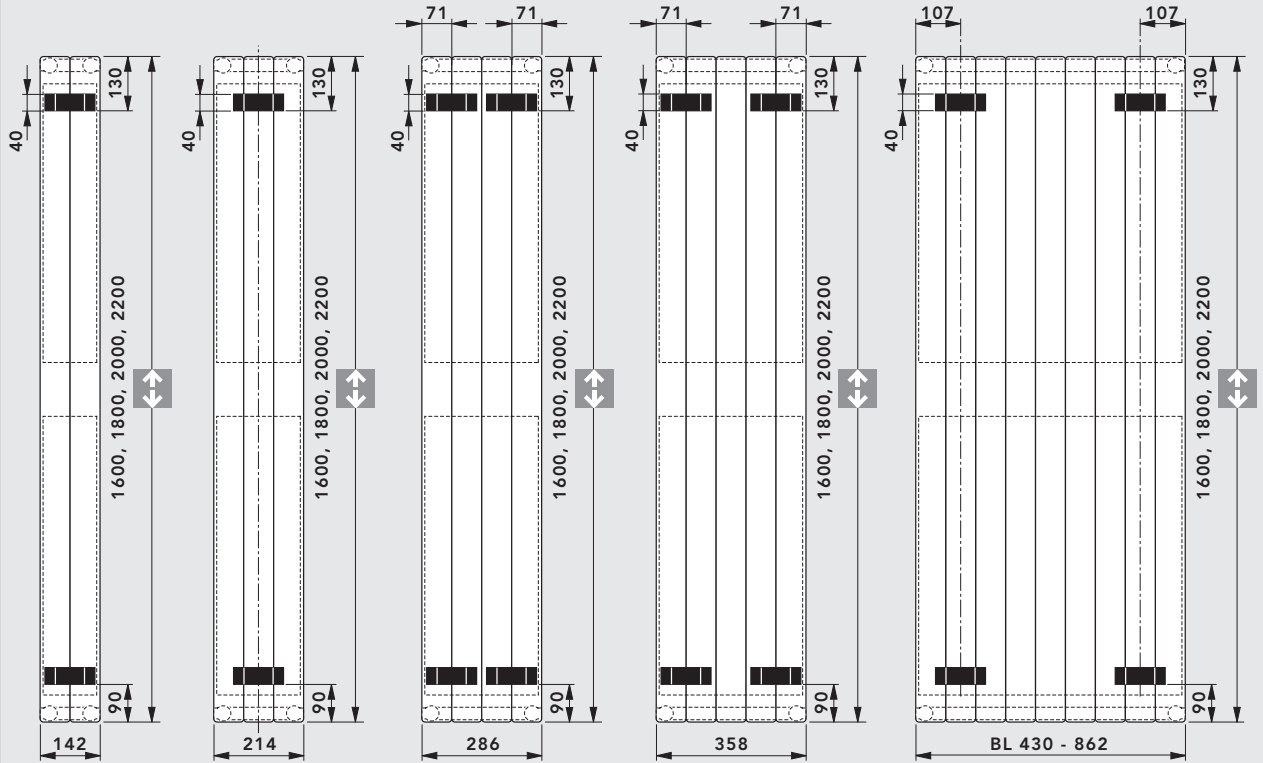

KS 10

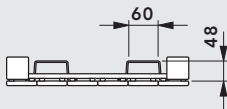

KS 11

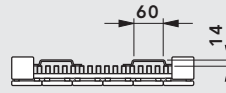

KS 20



KS 21

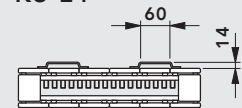

Schematic diagram

Wall clearance: WA 10 and WA 11 wall mounting brackets for the KS models

Connection – wall clearance

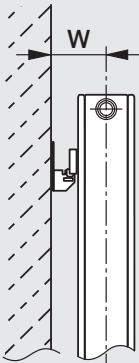
	Wall mounting brackets model	Vertical design model	Measurement W [mm]
	WA 10	KS 10/11*	35
WA 10	KS 20/21	79,5	
WA 11	KS 10/11*	45	
WA 11	KS 20/21	89,5	

***Note:** if you are installing the KS 10 and KS 11 models with a right-angled-design connection, please use the appropriate drilling consoles or angle-fish-plate mounting brackets, to achieve the required wall clearance.

Schematic diagram

Wall consoles WK 10 – 13: positioning for KK models (convectors)

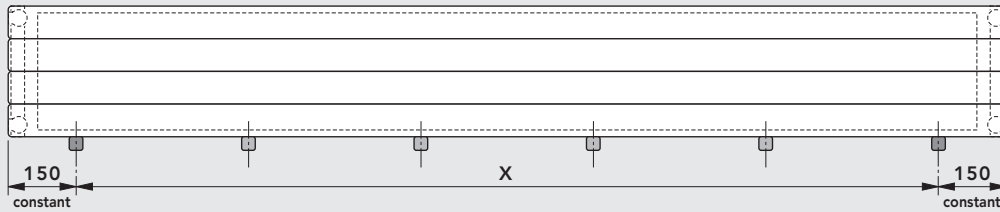

Note: when using more than 2 wall consoles the additional wall consoles must be placed at regular intervals along the line X.

WK 10 wall console

WK 11 wall console

KK 11

KK 20

KK 22

KK 23

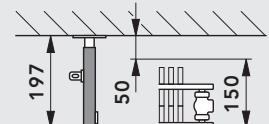
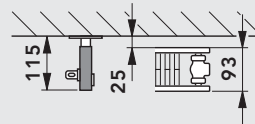
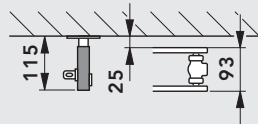
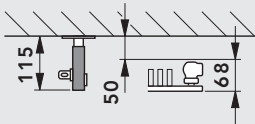

WK 11 wall console

WK 12 wall console

WK 13 wall console

KK 34

KK 35

KK 46

KK 58

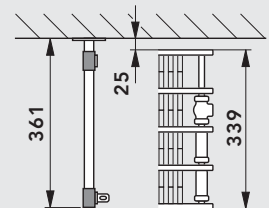
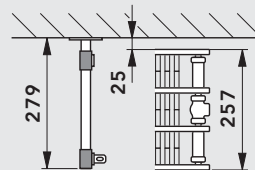
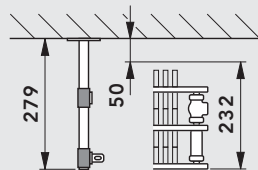
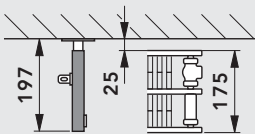

Schematic diagram

Stand consoles SK 22 and SK 23: positioning for KH models (horizontal design heating panels)

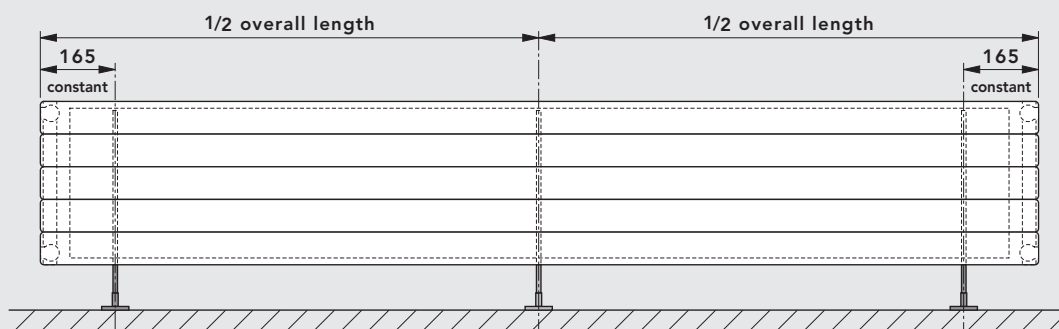

Note: for an overall length of 2200 mm and greater, a 3rd stand console must be used!

Schematic diagram

Stand consoles SK 10 – 19: positioning for the KK / KK-S models

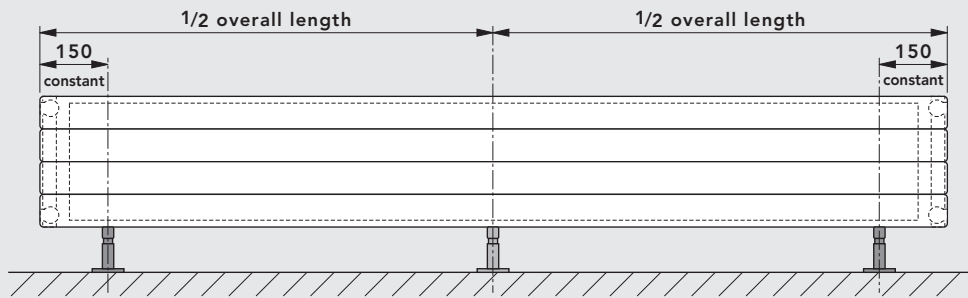

Note: for an overall length of 2200 mm and greater, a 3rd stand console must be used!

SK 10 / SK 11

KK 11

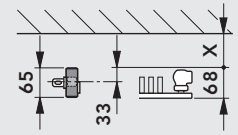

SK 12 / SK 13

KK 20

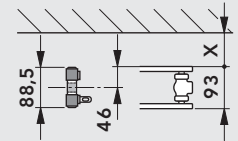

SK 12 / SK 13

SK 14 / SK 15

KK 22

KK 23

KK-S 22

KK 34

KK 35

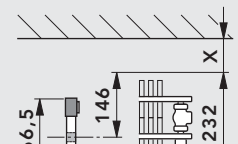
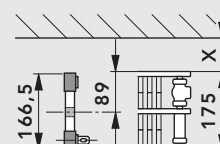
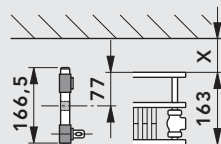
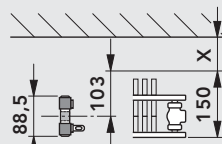
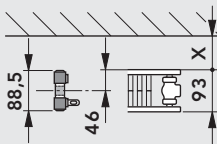

SK 14 / SK 15

SK 16 / SK 17

SK 18 / SK 19

KK-S 34

KK 46

KK-S 47

KK 58

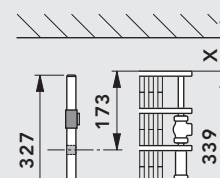
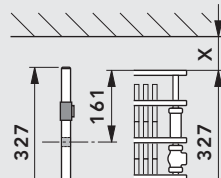
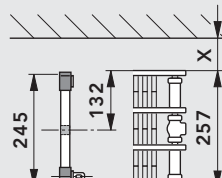
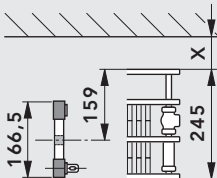

Measurement X:
chosen distance between the wall or window surface and the back of the convector.

Schematic diagram

Window sill support FBT 20: positioning for KK / KK-S models

Window sill support for subsequent installation with the KK / KK-S 22 – 58 models of KONTEC convectors

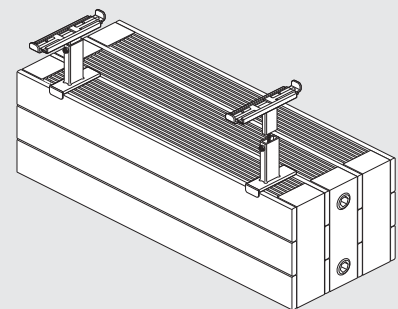
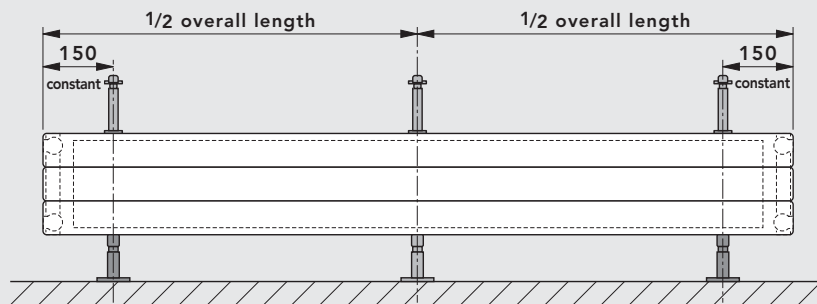

Note: for an overall length of more than 2200 mm, a 3rd window sill support must be used!

Schematic diagram

Heating output in compliance with DIN EN 442, and ÖNORM EN 442, at 75/65/20° C

Side panels and top cover are included in the heat output specifications



Overall depth
68 mm

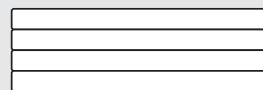
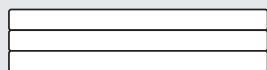

Overall height
[mm]









214
286
Model
KK 11
KK 11

Overall length
[mm]

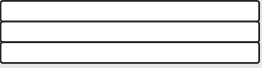
**Output
[Watts]**
**Output
[Watts]**
500
232
289
600
278
346
700
325
404
800
371
462
900
418
519
1000
464
577
1100
510
635
1200
557
692
1300
603
750
1400
650
808
1600
742
923
1800
835
1039
2000
928
1154
2200
1021
1269
2400
1114
1385
2600
1206
1500
2800
1299
1616
3000
1392
1731
3200
1485
1846
3400
1578
1962
3600
1670
2077
3800
1763
2193
4000
1856
2308
Watts/m 70/55/20
374
464
Watts/m 55/45/20
236
291
Water content l/m
1,67
2,22
Weight kg/m
11,14
14,51
Radiator exponent n
1,32
1,34

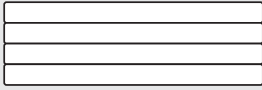

Heating output in compliance with DIN EN 442, and ÖNORM EN 442, at 75/65/20° C

Side panels and top cover are included in the heat output specifications

 Overall depth 93 mm	 	 	 
 Overall height [mm]	142	214	286
Model	KK 20	KK 20	KK 20
 Overall length [mm]	Output [Watts]	Output [Watts]	Output [Watts]
500	152	220	281
600	182	264	337
700	213	308	393
800	243	352	449
900	274	396	505
1000	304	440	561
1100	334	484	617
1200	365	528	673
1300	395	572	729
1400	426	616	785
1600	486	704	898
1800	547	792	1010
2000	608	880	1122
2200	669	968	1234
2400	730	1056	1346
2600	790	1144	1459
2800	851	1232	1571
3000	912	1320	1683
3200	973	1408	1795
3400	1034	1496	1907
3600	1094	1584	2020
3800	1155	1672	2132
4000	1216	1760	2244
Watts/m 70/55/20	249	359	458
Watts/m 55/45/20	161	232	296
Water content l/m	2,18	3,34	4,44
Weight kg/m	9,26	13,27	17,28
Radiator exponent n	1,24	1,25	1,25



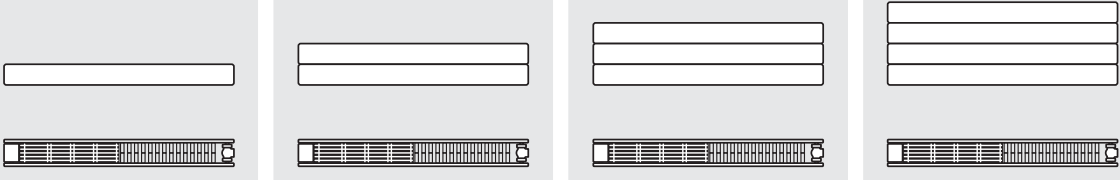

Heating output in compliance with DIN EN 442, and ÖNORM EN 442, at 75/65/20° C

Side panels and top cover are included in the heat output specifications

 Overall depth 93 mm				
	 Overall height [mm]	70	142	214
Model	KK 22	KK 22	KK 22	KK 22
 Overall length [mm]	Output [Watts]	Output [Watts]	Output [Watts]	Output [Watts]
500	212	321	419	516
600	254	385	503	619
700	297	449	587	722
800	339	513	670	826
900	382	577	754	929
1000	424	641	838	1032
1100	466	705	922	1135
1200	509	769	1006	1238
1300	551	833	1089	1342
1400	594	897	1173	1445
1600	678	1026	1341	1651
1800	763	1154	1508	1858
2000	848	1282	1676	2064
2200	933	1410	1844	2270
2400	1018	1538	2011	2477
2600	1102	1667	2179	2683
2800	1187	1795	2346	2890
3000	1272	1923	2514	3096
3200	1357	2051	2682	3302
3400	1442	2179	2849	3509
3600	1526	2308	3017	3715
3800	1611	2436	3184	3922
4000	1696	2564	3352	4128
Watts/m 70/55/20	345	519	674	825
Watts/m 55/45/20	222	330	423	510
Water content l/m	1,10	2,18	3,34	4,44
Weight kg/m	7,34	13,97	20,59	27,23
Radiator exponent n	1,27	1,30	1,34	1,38

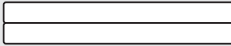
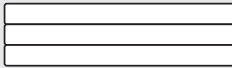
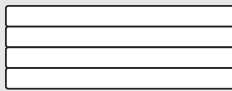

Heating output in compliance with DIN EN 442, and ÖNORM EN 442, at 75/65/20° C

Side panels and top cover are included in the heat output specifications

 Overall depth 163 mm	WVO-design	WVO-design	WVO-design	WVO-design
				
 Overall height [mm]	70	142	214	286
Model	KK-S 22	KK-S 22	KK-S 22	KK-S 22
 Overall length [mm]	Output [Watts]	Output [Watts]	Output [Watts]	Output [Watts]
500	212	321	419	516
600	254	385	503	619
700	297	449	587	722
800	339	513	670	826
900	382	577	754	929
1000	424	641	838	1032
1100	466	705	922	1135
1200	509	769	1006	1238
1300	551	833	1089	1342
1400	594	897	1173	1445
1600	678	1026	1341	1651
1800	763	1154	1508	1858
2000	848	1282	1676	2064
2200	933	1410	1844	2270
2400	1018	1538	2011	2477
2600	1102	1667	2179	2683
2800	1187	1795	2346	2890
3000	1272	1923	2514	3096
3200	1357	2051	2682	3302
3400	1442	2179	2849	3509
3600	1526	2308	3017	3715
3800	1611	2436	3184	3922
4000	1696	2564	3352	4128
Watts/m 70/55/20	345	519	674	825
Watts/m 55/45/20	222	330	423	510
Water content l/m	1,10	2,18	3,34	4,44
Weight kg/m	10,53	19,43	28,34	37,24
Radiator exponent n	1,27	1,30	1,34	1,38

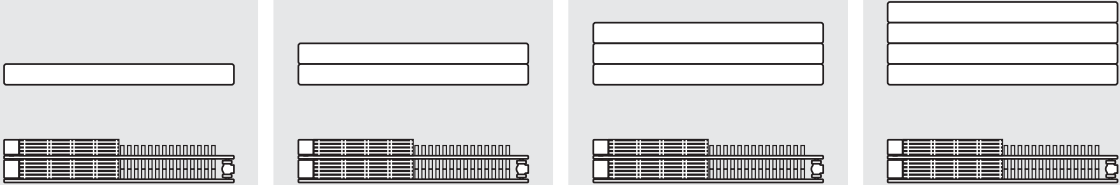

Heating output in compliance with DIN EN 442, and ÖNORM EN 442, at 75/65/20° C

Side panels and top cover are included in the heat output specifications

 Overall depth 150 mm				
	 Overall height [mm]	70	142	214
Model	KK 23	KK 23	KK 23	KK 23
 Overall length [mm]	Output [Watts]	Output [Watts]	Output [Watts]	Output [Watts]
500	262	399	518	631
600	314	478	621	757
700	367	558	725	883
800	419	638	828	1009
900	472	717	932	1135
1000	524	797	1035	1261
1100	576	877	1139	1387
1200	629	956	1242	1513
1300	681	1036	1346	1639
1400	734	1116	1449	1765
1600	838	1275	1656	2018
1800	943	1435	1863	2270
2000	1048	1594	2070	2522
2200	1153	1753	2277	2774
2400	1258	1913	2484	3026
2600	1362	2072	2691	3279
2800	1467	2232	2898	3531
3000	1572	2391	3105	3783
3200	1677	2550	3312	4035
3400	1782	2710	3519	4287
3600	1886	2869	3726	4540
3800	1991	3029	3933	4792
4000	2096	3188	4140	5044
Watts/m 70/55/20	427	645	832	1008
Watts/m 55/45/20	275	410	522	623
Water content l/m	1,10	2,18	3,34	4,44
Weight kg/m	9,20	17,02	24,84	32,66
Radiator exponent n	1,26	1,30	1,34	1,38

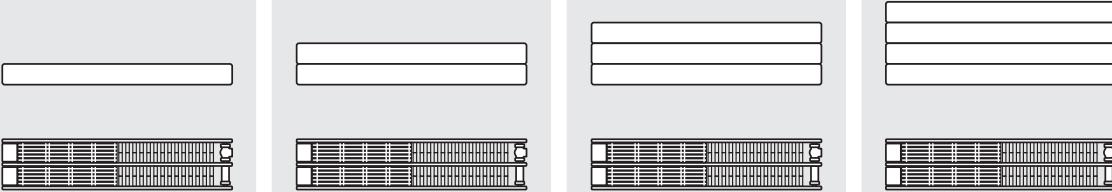

Heating output in compliance with DIN EN 442, and ÖNORM EN 442, at 75/65/20° C

Side panels and top cover are included in the heat output specifications

 Overall depth 175 mm				
	 Overall height [mm]	70	142	214
Model	KK 34	KK 34	KK 34	KK 34
 Overall length [mm]	Output [Watts]	Output [Watts]	Output [Watts]	Output [Watts]
500	331	525	697	862
600	397	630	836	1034
700	463	735	976	1206
800	529	840	1115	1378
900	595	945	1255	1551
1000	661	1050	1394	1723
1100	727	1155	1533	1895
1200	793	1260	1673	2068
1300	859	1365	1812	2240
1400	925	1470	1952	2412
1600	1058	1680	2230	2757
1800	1190	1890	2509	3101
2000	1322	2100	2788	3446
2200	1454	2310	3067	3791
2400	1586	2520	3346	4135
2600	1719	2730	3624	4480
2800	1851	2940	3903	4824
3000	1983	3150	4182	5169
3200	2115	3360	4461	5514
3400	2247	3570	4740	5858
3600	2380	3780	5018	6203
3800	2512	3990	5297	6547
4000	2644	4200	5576	6892
Watts/m 70/55/20	545	856	1123	1377
Watts/m 55/45/20	360	552	707	851
Water content l/m	1,68	3,33	4,99	6,66
Weight kg/m	12,68	23,93	35,18	46,42
Radiator exponent n	1,19	1,26	1,33	1,38

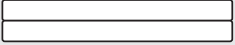
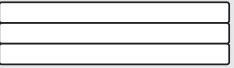
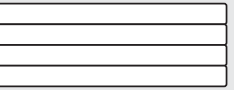

Heating output in compliance with DIN EN 442, and ÖNORM EN 442, at 75/65/20° C

Side panels and top cover are included in the heat output specifications

	WVO-design	WVO-design	WVO-design	WVO-design
Overall depth 245 mm				
 Overall height [mm]	70	142	214	286
Model	KK-S 34	KK-S 34	KK-S 34	KK-S 34
 Overall length [mm]	Output [Watts]	Output [Watts]	Output [Watts]	Output [Watts]
500	331	525	697	862
600	397	630	836	1034
700	463	735	976	1206
800	529	840	1115	1378
900	595	945	1255	1551
1000	661	1050	1394	1723
1100	727	1155	1533	1895
1200	793	1260	1673	2068
1300	859	1365	1812	2240
1400	925	1470	1952	2412
1600	1058	1680	2230	2757
1800	1190	1890	2509	3101
2000	1322	2100	2788	3446
2200	1454	2310	3067	3791
2400	1586	2520	3346	4135
2600	1719	2730	3624	4480
2800	1851	2940	3903	4824
3000	1983	3150	4182	5169
3200	2115	3360	4461	5514
3400	2247	3570	4740	5858
3600	2380	3780	5018	6203
3800	2512	3990	5297	6547
4000	2644	4200	5576	6892
Watts/m 70/55/20	545	856	1123	1377
Watts/m 55/45/20	360	552	707	851
Water content l/m	1,68	3,33	4,99	6,66
Weight kg/m	15,87	29,39	42,92	56,44
Radiator exponent n	1,19	1,26	1,33	1,38



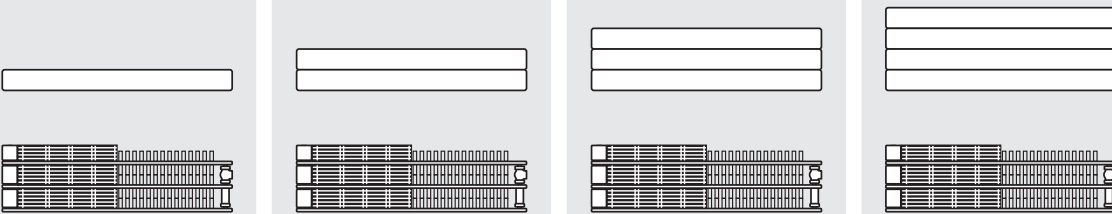

Heating output in compliance with DIN EN 442, and ÖNORM EN 442, at 75/65/20° C

Side panels and top cover are included in the heat output specifications

 Overall depth 232 mm				
	 Overall height [mm]	70	142	214
Model	KK 35			
 Overall length [mm]	Output [Watts]	Output [Watts]	Output [Watts]	Output [Watts]
500	405	599	826	986
600	485	718	991	1183
700	566	838	1156	1380
800	647	958	1321	1577
900	728	1077	1486	1774
1000	809	1197	1651	1971
1100	890	1317	1816	2168
1200	971	1436	1981	2365
1300	1052	1556	2146	2562
1400	1133	1676	2311	2759
1600	1294	1915	2642	3154
1800	1456	2155	2972	3548
2000	1618	2394	3302	3942
2200	1780	2633	3632	4336
2400	1942	2873	3962	4730
2600	2103	3112	4293	5125
2800	2265	3352	4623	5519
3000	2427	3591	4953	5913
3200	2589	3830	5283	6307
3400	2751	4070	5613	6701
3600	2912	4309	5944	7096
3800	3074	4549	6274	7490
4000	3236	4788	6604	7884
Watts/m 70/55/20	661	971	1326	1570
Watts/m 55/45/20	429	619	828	964
Water content l/m	1,69	3,33	4,99	6,66
Weight kg/m	14,54	26,98	39,42	51,86
Radiator exponent n	1,24	1,29	1,35	1,40

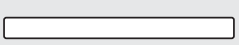
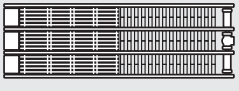

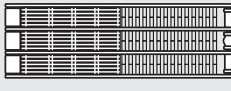
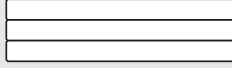
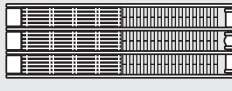
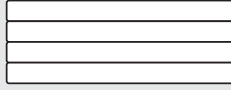
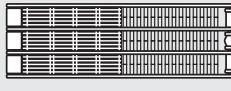

Heating output in compliance with DIN EN 442, and ÖNORM EN 442, at 75/65/20° C

Side panels and top cover are included in the heat output specifications

 Overall depth 257 mm	 	 	 	 
 Overall height [mm]	70	142	214	286
Model	KK 46	KK 46	KK 46	KK 46
 Overall length [mm]	Output [Watts]	Output [Watts]	Output [Watts]	Output [Watts]
500	475	727	1036	1224
600	570	872	1243	1468
700	665	1018	1450	1713
800	760	1163	1658	1958
900	855	1309	1865	2202
1000	950	1454	2072	2447
1100	1045	1599	2279	2692
1200	1140	1745	2486	2936
1300	1235	1890	2694	3181
1400	1330	2036	2901	3426
1600	1520	2326	3315	3915
1800	1710	2617	3730	4405
2000	1900	2908	4144	4894
2200	2090	3199	4558	5383
2400	2280	3490	4973	5873
2600	2470	3780	5387	6362
2800	2660	4071	5802	6852
3000	2850	4362	6216	7341
Watts/m 70/55/20	778	1117	1661	1949
Watts/m 55/45/20	507	748	1034	1197
Water content l/m	2,26	4,53	6,79	9,06
Weight kg/m	18,02	33,89	49,76	65,62
Radiator exponent n	1,23	1,30	1,36	1,40

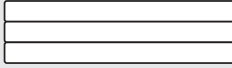
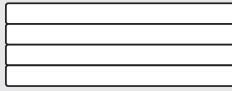

Heating output in compliance with DIN EN 442, and ÖNORM EN 442, at 75/65/20° C

Side panels and top cover are included in the heat output specifications

	WVO-design	WVO-design	WVO-design	WVO-design
 Overall depth 327 mm				
 Overall height [mm]	70	142	214	286
Model	KK-S 47	KK-S 47	KK-S 47	KK-S 47
 Overall length [mm]	Output [Watts]	Output [Watts]	Output [Watts]	Output [Watts]
500	493	761	1151	1334
600	592	913	1381	1600
700	690	1065	1611	1867
800	789	1218	1842	2134
900	887	1370	2072	2400
1000	986	1522	2302	2667
1100	1085	1674	2532	2934
1200	1183	1826	2762	3200
1300	1282	1979	2993	3467
1400	1380	2131	3223	3734
1600	1578	2435	3683	4267
1800	1775	2740	4144	4801
2000	1972	3044	4604	5334
2200	2169	3348	5064	5867
2400	2366	3653	5525	6401
2600	2564	3957	5985	6934
2800	2761	4262	6446	7468
Watts/m 70/55/20	817	1240	1846	2128
Watts/m 55/45/20	545	800	1149	1311
Water content l/m	2,26	4,53	6,79	9,06
Weight kg/m	22,04	41,27	60,50	79,74
Radiator exponent n	1,16	1,26	1,36	1,39

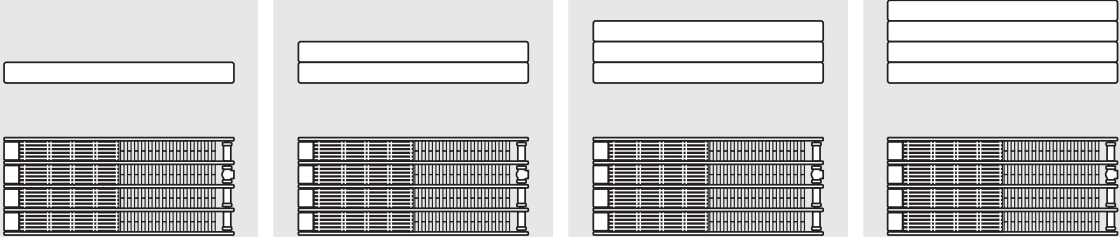

Heating output in compliance with DIN EN 442, and ÖNORM EN 442, at 75/65/20° C

Side panels and top cover are included in the heat output specifications

 Overall depth 339 mm				
	 Overall height [mm]	70	142	214
Model	KK 58	KK 58	KK 58	KK 58
 Overall length [mm]	Output [Watts]	Output [Watts]	Output [Watts]	Output [Watts]
500	512	830	1296	1511
600	614	995	1555	1813
700	716	1161	1814	2115
800	818	1327	2074	2418
900	921	1493	2333	2720
1000	1023	1659	2592	3022
1100	1125	1825	2851	3324
1200	1228	1991	3110	3626
1300	1330	2157	3370	3929
1400	1432	2323	3629	4231
1600	1637	2654	4147	4835
1800	1841	2986	4666	5440
2000	2046	3318	5184	6044
2200	2251	3650	5702	6648
Watts/m 70/55/20	849	1354	2081	2411
Watts/m 55/45/20	569	876	1301	1486
Water content l/m	2,83	5,68	8,52	11,36
Weight kg/m	23,36	43,85	64,34	85,82
Radiator exponent n	1,15	1,25	1,35	1,39



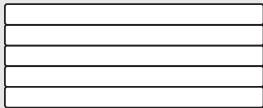
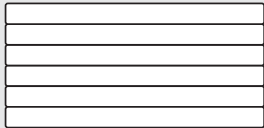
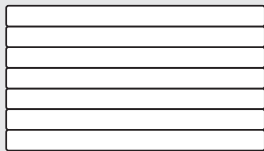



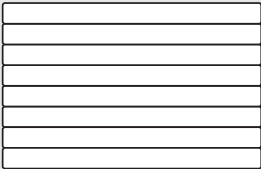

Heating output in compliance with DIN EN 442, and ÖNORM EN 442, at 75/65/20° C

Side panels and top cover are included in the heat output specifications

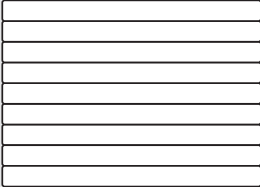
	Overall depth 68 mm			
	Overall height [mm]	358	430	502
Model	KH 10	KH 10	KH 10	
	Overall length [mm]	Output [Watts]	Output [Watts]	Output [Watts]
500	197	229	262	
600	236	275	314	
700	276	321	366	
800	315	366	418	
900	355	412	471	
1000	394	458	523	
1100	433	504	575	
1200	473	550	628	
1300	512	595	680	
1400	552	641	732	
1600	630	733	837	
1800	709	824	941	
2000	788	916	1046	
2200	867	1008	1151	
2400	946	1099	1255	
2600	1024	1191	1360	
2800	1103	1282	1464	
3000	1182	1374	1569	
3200	1261	1466	1674	
3400	1340	1557	1778	
3600	1418	1649	1883	
3800	1497	1740	1987	
4000	1576	1832	2092	
Watts/m 70/55/20	322	374	427	
Watts/m 55/45/20	209	243	276	
Water content l/m	2,76	3,33	3,87	
Weight kg/m	11,91	14,04	16,17	
Radiator exponent n	1,24	1,24	1,25	

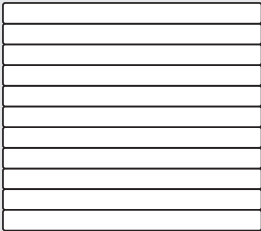

Heating output in compliance with DIN EN 442, and ÖNORM EN 442, at 75/65/20° C

Side panels and top cover are included in the heat output specifications

 Overall depth 68 mm	 	 	 
	 Overall height [mm]	574	646
Model	KH 10	KH 10	KH 10
 Overall length [mm]	Output [Watts]	Output [Watts]	Output [Watts]
500	294	328	398
600	353	393	477
700	412	459	557
800	470	524	636
900	529	590	716
1000	588	655	795
1100	647	721	875
1200	706	786	954
1300	764	852	1034
1400	823	917	1113
1600	941	1048	1272
1800	1058	1179	1431
2000	1176	1310	1590
2200	1294	1441	1749
2400	1411	1572	1908
2600	1529	1703	2067
2800	1646	1834	2226
3000	1764	1965	2385
3200	1882	2096	
3400	1999	2227	
3600	2117	2358	
3800	2234	2489	
4000	2352	2620	
Watts/m 70/55/20	480	534	647
Watts/m 55/45/20	311	344	416
Water content l/m	4,44	4,99	6,12
Weight kg/m	18,29	20,43	24,68
Radiator exponent n	1,25	1,26	1,27



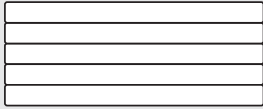
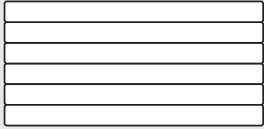
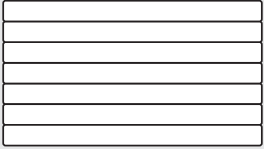



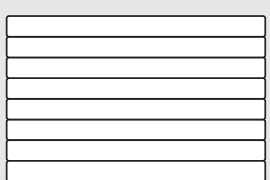

Heating output in compliance with DIN EN 442, and ÖNORM EN 442, at 75/65/20° C

Side panels and top cover are included in the heat output specifications

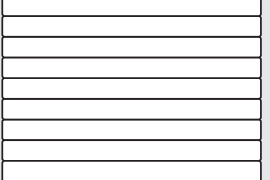
	Overall depth 68 mm			
	Overall height [mm]	358	430	502
Model	KH 11	KH 11	KH 11	
	Overall length [mm]	Output [Watts]	Output [Watts]	Output [Watts]
500	334	380	423	
600	400	456	507	
700	467	532	592	
800	534	608	676	
900	600	684	761	
1000	667	760	845	
1100	734	836	930	
1200	800	912	1014	
1300	867	988	1099	
1400	934	1064	1183	
1600	1067	1216	1352	
1800	1201	1368	1521	
2000	1334	1520	1690	
2200	1467	1672	1859	
2400	1601	1824	2028	
2600	1734	1976	2197	
2800	1868	2128	2366	
3000	2001	2280	2535	
3200	2134	2432	2704	
3400	2268	2584	2873	
3600	2401	2736	3042	
3800	2535	2888	3211	
4000	2668	3040	3380	
Watts/m 70/55/20	540	615	683	
Watts/m 55/45/20	344	391	433	
Water content l/m	2,78	3,33	3,87	
Weight kg/m	16,71	19,85	22,99	
Radiator exponent n	1,30	1,30	1,31	

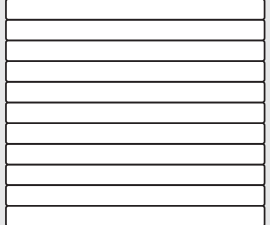





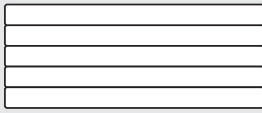

Heating output in compliance with DIN EN 442, and ÖNORM EN 442, at 75/65/20° C

Side panels and top cover are included in the heat output specifications

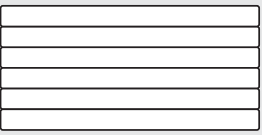
 Overall depth 68 mm	 	 	 
 Overall height [mm]	574	646	790
Model	KH 11	KH 11	KH 11
 Overall length [mm]	Output [Watts]	Output [Watts]	Output [Watts]
500	461	495	553
600	553	593	663
700	645	692	774
800	737	791	884
900	829	890	995
1000	921	989	1105
1100	1013	1088	1216
1200	1105	1187	1326
1300	1197	1286	1437
1400	1289	1385	1547
1600	1474	1582	1768
1800	1658	1780	1989
2000	1842	1978	2210
2200	2026	2176	2431
2400	2210	2374	2652
2600	2395	2571	2873
2800	2579	2769	3094
3000	2763	2967	3315
3200	2947	3165	
3400	3131	3363	
3600	3316	3560	
3800	3500	3758	
4000	3684	3956	
Watts/m 70/55/20	743	797	889
Watts/m 55/45/20	470	503	558
Water content l/m	4,44	4,99	6,12
Weight kg/m	26,15	29,29	33,55
Radiator exponent n	1,32	1,32	1,34

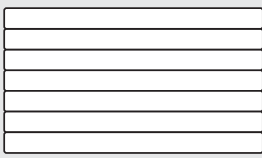





Heating output in compliance with DIN EN 442, and ÖNORM EN 442, at 75/65/20° C

Side panels and top cover are included in the heat output specifications

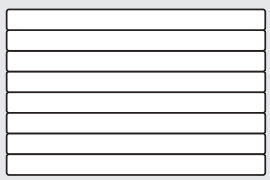
 Overall depth 93 mm	 	 	 
 Overall height [mm]	358	430	502
Model	KH 20	KH 20	KH 20
 Overall length [mm]	Output [Watts]	Output [Watts]	Output [Watts]
500	327	379	430
600	392	454	515
700	458	530	601
800	523	606	687
900	589	681	773
1000	654	757	859
1100	719	833	945
1200	785	908	1031
1300	850	984	1117
1400	916	1060	1203
1600	1046	1211	1374
1800	1177	1363	1546
2000	1308	1514	1718
2200	1439	1665	1890
2400	1570	1817	2062
2600	1700	1968	2233
2800	1831	2120	2405
3000	1962	2271	2577
3200	2093	2422	2749
3400	2224	2574	2921
3600	2354	2725	3092
3800	2485	2877	3264
4000	2616	3028	3436
Watts/m 70/55/20	533	617	699
Watts/m 55/45/20	344	398	449
Water content l/m	5,55	6,66	7,77
Weight kg/m	21,29	25,30	29,31
Radiator exponent n	1,26	1,26	1,27

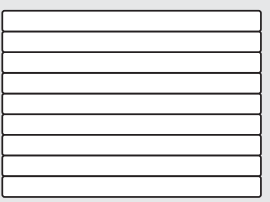
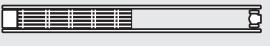
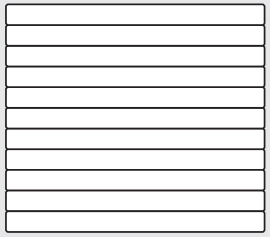
Heating output in compliance with DIN EN 442, and ÖNORM EN 442, at 75/65/20° C

Side panels and top cover are included in the heat output specifications

 Overall depth 93 mm	 	 	 
 Overall height [mm]	574	646	790
Model	KH 20	KH 20	KH 20
 Overall length [mm]	Output [Watts]	Output [Watts]	Output [Watts]
500	480	532	636
600	576	638	763
700	672	744	890
800	768	850	1017
900	864	957	1144
1000	960	1063	1271
1100	1056	1169	1398
1200	1152	1276	1525
1300	1248	1382	1652
1400	1344	1488	1779
1600	1536	1701	2034
1800	1728	1913	2288
2000	1920	2126	2542
2200	2112	2339	2796
2400	2304	2551	3050
2600	2496	2764	3305
2800	2688	2976	3559
3000	2880	3189	3813
3200	3072	3402	
3400	3264	3614	
3600	3456	3827	
3800	3648	4039	
4000	3840	4252	
Watts/m 70/55/20	781	863	1032
Watts/m 55/45/20	502	553	661
Water content l/m	8,88	9,99	12,22
Weight kg/m	33,31	37,32	45,33
Radiator exponent n	1,27	1,28	1,28

Heating output in compliance with DIN EN 442, and ÖNORM EN 442, at 75/65/20° C

Side panels and top cover are included in the heat output specifications



Overall depth
93 mm

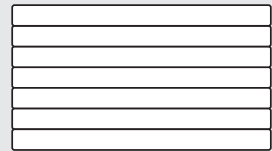
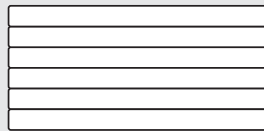
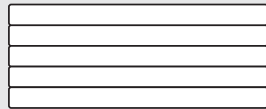

Overall height
[mm]

358

430

502

Model

KH 22

KH 22

KH 22



Overall length
[mm]

Output
[Watts]

Output
[Watts]

Output
[Watts]

500

599

672

737

600

718

806

884

700

838

940

1032

800

958

1074

1179

900

1077

1209

1327

1000

1197

1343

1474

1100

1317

1477

1621

1200

1436

1612

1769

1300

1556

1746

1916

1400

1676

1880

2064

1600

1915

2149

2358

1800

2155

2417

2653

2000

2394

2686

2948

2200

2633

2955

3243

2400

2873

3223

3538

2600

3112

3492

3832

2800

3352

3760

4127

3000

3591

4029

4422

3200

3830

4298

4717

3400

4070

4566

5012

3600

4309

4835

5306

3800

4549

5103

5601

4000

4788

5372

5896

Watts/m 70/55/20

963

1079

1182

Watts/m 55/45/20

605

675

736

Water content l/m

5,55

6,66

7,77

Weight kg/m

30,89

36,93

42,96

Radiator exponent n

1,34

1,35

1,36

Heating output in compliance with DIN EN 442, and ÖNORM EN 442, at 75/65/20° C

Side panels and top cover are included in the heat output specifications



Overall depth
93 mm

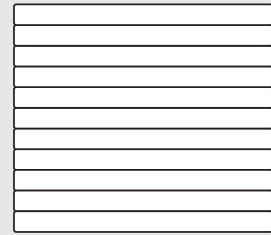
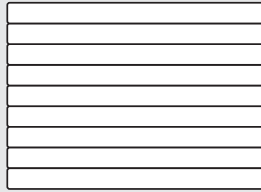
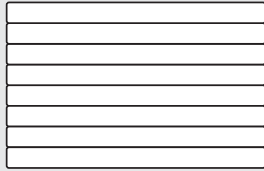

Overall height
[mm]

574

646

790

Model

KH 22

KH 22

KH 22



Overall length
[mm]

Output
[Watts]

Output
[Watts]

Output
[Watts]

500

796

850

943

600

955

1019

1132

700

1114

1189

1320

800

1274

1359

1509

900

1433

1529

1697

1000

1592

1699

1886

1100

1751

1869

2075

1200

1910

2039

2263

1300

2070

2209

2452

1400

2229

2379

2640

1600

2547

2718

3018

1800

2866

3058

3395

2000

3184

3398

3772

2200

3502

3738

4149

2400

3821

4078

4526

2600

4139

4417

4904

2800

4458

4757

5281

3000

4776

5097

5658

3200

5094

5437

3400

5413

5777

3600

5731

6116

3800

6050

6456

4000

6368

6796

Watts/m 70/55/20

1274

1357

1500

Watts/m 55/45/20

790

838

919

Water content l/m

8,88

9,99

12,22

Weight kg/m

49,01

55,05

63,06

Radiator exponent n

1,37

1,38

1,41

Heating output in compliance with DIN EN 442, and ÖNORM EN 442, at 75/65/20° C

Side panels and top cover are included in the heat output specifications



Overall depth
68 mm

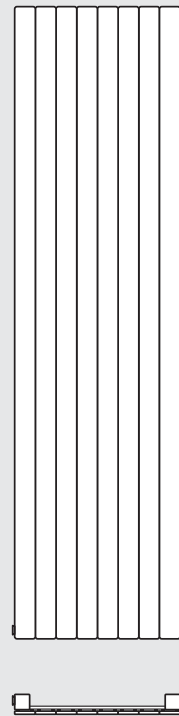
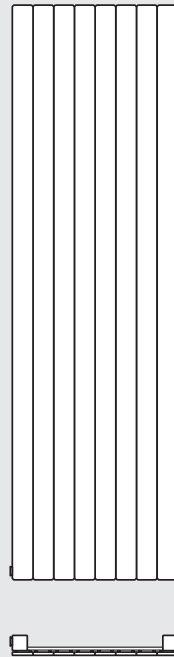
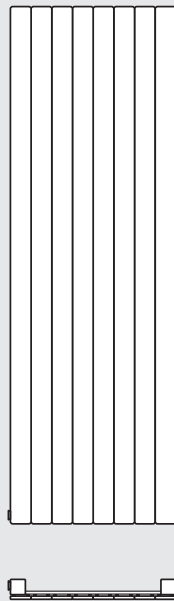
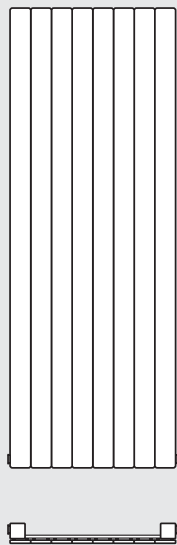

Overall height
[mm]

1600

1800

2000

2200

Model

KS 10

KS 10

KS 10

KS 10



Overall length
[mm]

Output
[Watts]

Output
[Watts]

Output
[Watts]

Output
[Watts]

142

247

281

317

354

214

372

424

478

534

286

497

566

638

714

358

622

708

799

893

430

747

851

960

1073

502

872

993

1120

1253

574

998

1136

1281

1432

646

1123

1278

1442

1612

718

1248

1421

1603

1791

790

1373

1563

1763

1971

862

1498

1706

1924

2151

Watts/m 70/55/20

1384

1577

1781

1994

Watts/m 55/45/20

850

968

1097

1233

Water content l/m

11,37

12,47

13,85

15,24

Weight kg/m

44,45

49,60

54,75

59,70

Radiator exponent n

1,40

1,40

1,39

1,38

Heating output in compliance with DIN EN 442, and ÖNORM EN 442, at 75/65/20° C

Side panels and top cover are included in the heat output specifications



Overall depth 68 mm

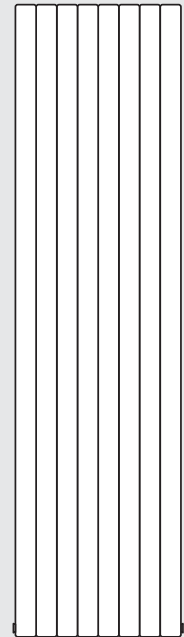
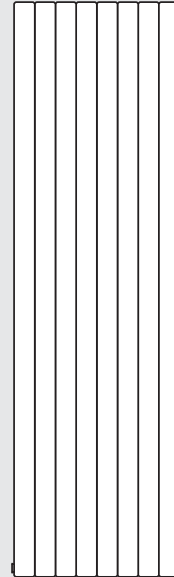
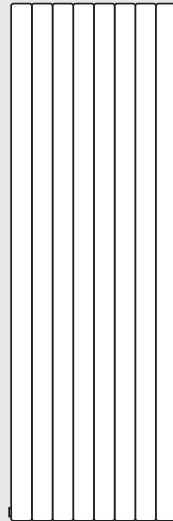
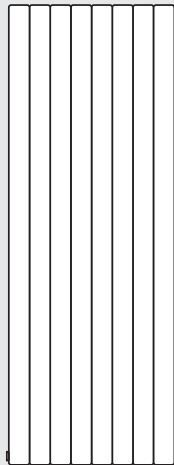

Overall height [mm]

1600

1800

2000

2200

Model

KS 11

KS 11

KS 11

KS 11



Overall length [mm]

Output [Watts]

Output [Watts]

Output [Watts]

Output [Watts]

142

281

314

348

384

214

424

473

524

578

286

566

632

701

773

358

708

791

877

967

430

851

950

1054

1161

502

993

1109

1230

1356

574

1136

1268

1406

1550

646

1278

1427

1583

1745

718

1421

1586

1759

1939

790

1563

1745

1936

2134

862

1706

1904

2112

2328

Watts/m 70/55/20

1584

1768

1964

2173

Watts/m 55/45/20

983

1097

1223

1362

Water content l/m

11,37

12,47

13,85

15,24

Weight kg/m

63,39

68,53

73,69

78,83

Radiator exponent n

1,37

1,37

1,36

1,34

Heating output in compliance with DIN EN 442, and ÖNORM EN 442, at 75/65/20° C

Side panels and top cover are included in the heat output specifications



Overall depth
93 mm

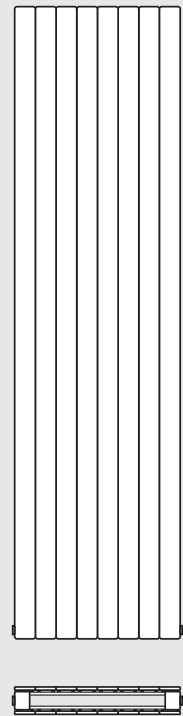
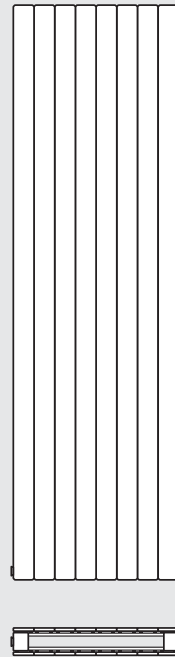
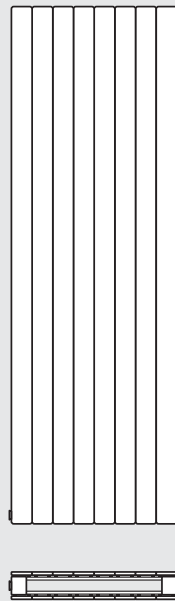
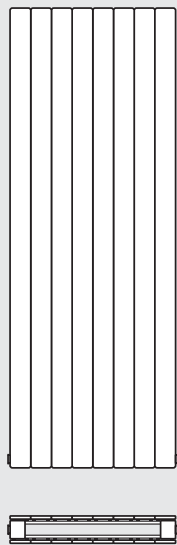

Overall height
[mm]

1600

1800

2000

2200

Model

KS 20

KS 20

KS 20

KS 20



Overall length
[mm]

Output
[Watts]

Output
[Watts]

Output
[Watts]

Output
[Watts]

142

416

469

521

575

214

627

706

786

866

286

839

944

1050

1157

358

1050

1182

1315

1449

430

1261

1419

1579

1740

502

1472

1657

1843

2031

574

1683

1895

2108

2322

646

1894

2132

2372

2614

718

2105

2370

2636

2905

790

2316

2608

2901

3196

862

2527

2845

3165

3488

Watts/m 70/55/20

2332

2629

2929

3233

Watts/m 55/45/20

1427

1615

1805

1999

Water content l/m

22,74

24,34

27,71

30,48

Weight kg/m

85,44

95,46

105,48

115,50

Radiator exponent n

1,41

1,40

1,39

1,38

Heating output in compliance with DIN EN 442, and ÖNORM EN 442, at 75/65/20° C

Side panels and top cover are included in the heat output specifications



Overall depth 93 mm

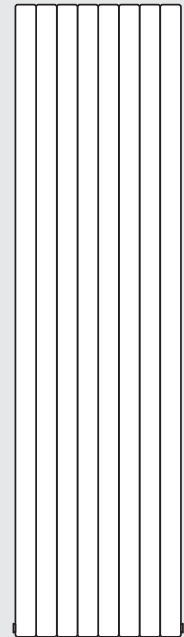
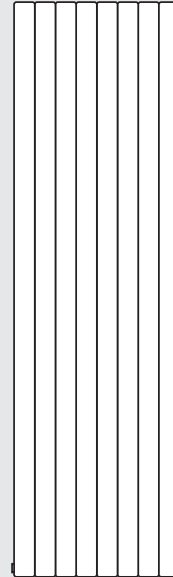
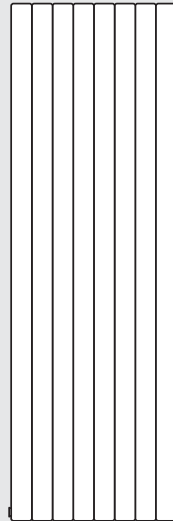
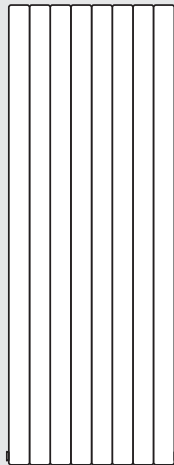

Overall height [mm]

1600

1800

2000

2200

Model

KS 21

KS 21

KS 21

KS 21



Overall length [mm]

Output [Watts]

Output [Watts]

Output [Watts]

Output [Watts]

142

452

510

570

633

214

681

768

859

953

286

911

1026

1147

1274

358

1140

1285

1436

1595

430

1369

1543

1725

1916

502

1598

1801

2014

2236

574

1828

2060

2303

2557

646

2057

2318

2592

2879

718

2286

2576

2881

3199

790

2515

2835

3169

3520

862

2745

3093

3458

3840

Watts/m 70/55/20

2536

2857

3206

3572

Watts/m 55/45/20

1557

1755

1983

2224

Water content l/m

22,74

24,34

27,71

30,48

Weight kg/m

104,37

114,39

124,42

134,44

Radiator exponent n

1,40

1,40

1,38

1,36

Simplified procedure for the domain of standard and low-temperature (ST/LT)

The conversion factors in the table state to which extent the heat emission has to be altered under other operating conditions, compared to the following standard-design data:

supply temperature t_1 75 °C
 return temperature t_2 65 °C
 room temperature t_r 20 °C

Because an average exponent of 1.3 has been used for both the calculation of the performance data and the specification of the conversion factor, a slight performance variation from the calculated value is possible.

The standard heat emission Φ_s of a radiator covering the required heat $\Phi_{HL,i}$ at the chosen operating conditions, is calculated according to the formula:

$$\Phi_s = \Phi_{HL,i} \times f$$

Φ_s = standard heat emission, in accordance with EN 442

$\Phi_{HL,i}$ = required heat, in accordance with EN 12831

f = conversion factor from the table

Example:

The required heat of a room is 1000 W, in accordance with EN 12831.

Design data: t_1 50 °C
 t_2 40 °C
 t_r 20 °C

Factor f according to the table = 2.50

Supply temperature °C	Return temperature °C	Room temperature °C						
		12	15	18	20	22	24	26
90	80	0,61	0,64	0,68	0,71	0,74	0,77	0,81
	70	0,67	0,72	0,76	0,80	0,83	0,87	0,91
80	70	0,74	0,79	0,84	0,88	0,93	0,97	1,03
	60	0,83	0,89	0,96	1,01	1,07	1,13	1,20
	50	0,96	1,04	1,13	1,20	1,28	1,37	1,47
75	65	0,82	0,88	0,95	1,00	1,05	1,12	1,18
	60	0,88	0,94	1,02	1,08	1,14	1,21	1,29
	55	0,94	1,01	1,10	1,17	1,24	1,32	1,42
70	65	0,87	0,94	1,01	1,07	1,13	1,19	1,27
	60	0,93	1,00	1,08	1,15	1,22	1,30	1,39
	55	0,99	1,08	1,17	1,25	1,33	1,42	1,53
	50	1,07	1,17	1,28	1,37	1,47	1,58	1,71
65	60	0,98	1,07	1,16	1,23	1,31	1,40	1,50
	55	1,05	1,15	1,26	1,34	1,43	1,54	1,66
	50	1,14	1,25	1,37	1,47	1,59	1,71	1,86
	45	1,24	1,37	1,52	1,64	1,78	1,94	2,13
60	55	1,13	1,23	1,36	1,45	1,56	1,68	1,82
	50	1,22	1,34	1,48	1,60	1,73	1,87	2,05
	45	1,33	1,47	1,65	1,78	1,94	2,13	2,36
	40	1,47	1,64	1,86	2,03	2,24	2,50	2,80
55	50	1,31	1,45	1,62	1,75	1,90	2,07	2,28
	45	1,43	1,60	1,80	1,96	2,15	2,37	2,64
	40	1,59	1,78	2,03	2,24	2,48	2,78	3,15
50	35	1,78	2,03	2,36	2,64	2,99	3,43	4,02
	45	1,56	1,75	1,98	2,17	2,40	2,67	3,00
	40	1,73	1,96	2,25	2,50	2,79	3,15	3,61
	35	1,94	2,24	2,63	2,96	3,38	3,92	4,64
45	30	2,24	2,64	3,20	3,70	4,39	5,39	6,99
	40	1,90	2,17	2,53	2,83	3,19	3,66	4,25
	35	2,15	2,50	2,96	3,37	3,89	4,58	5,52

$$\Phi_s = \Phi_{HL,i} \times f = 1000 \text{ Watts} \times 2,50 = 2500 \text{ Watts}$$

A radiator has to be installed that emits 2500 W under the standard design (75/65/20).

Exact method for the performance calculation for the domain of standard and low-temperature (ST/LT)

Using the formula $\Phi = \Phi_s \left[\frac{\Delta T}{\Delta T_s} \right]^n$ any performance differing from the standard can be calculated.

Φ = Radiator power [W]

Φ_s = Standard radiator power in accordance with EN 442 [W]

ΔT = Arithmetic radiator excess temperature [K]

ΔT_s = Arithmetic radiator excess temperature 50 K, at a standard state of 75 °C / 65 °C / 20 °C

n = Radiator exponent

Please note: if the condition $c = \frac{t_2 - t_r}{t_1 - t_r} < 0.7$ is met, the excess temperatures will be specified logarithmically.

$$\Delta T_{\text{arithmetic}} = \frac{t_1 + t_2}{2} - t_r$$

$$\Delta T_{\text{logarithmic}} = \frac{t_1 - t_2}{\ln \frac{t_1 - t_r}{t_2 - t_r}}$$

Horizontal design of VONARIS, VONARIS-M and KONTEC

Radiator placement

Placement below a window parapet

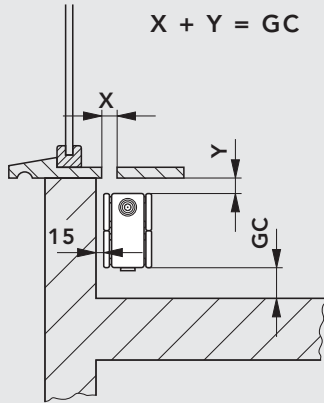

Placement under a bench

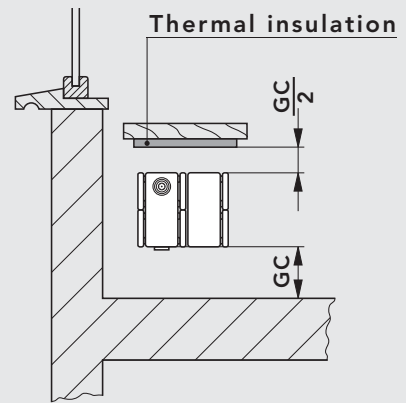

Placement behind a glass surface

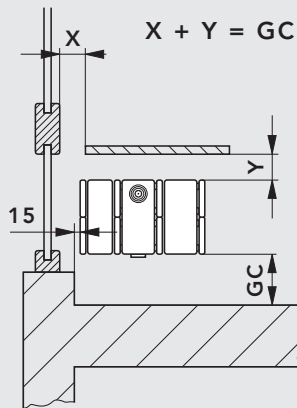

Placement below a shop window

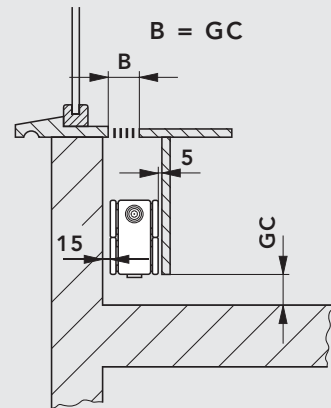

Schematic diagram

Recommended minimum clearance for convectors

GC [mm]	VONARIS			VONARIS-M			KONTEC		
	Model	OH [mm]	↑↓	Model	OH [mm]	↑↓	Model	OH [mm]	↑↓
GC = ground clearance in mm The minimum ground clearance recommended here apply for all images on the pages 113 and 114!	60	VHV 11	214, 286	VHV-M 11	214, 286		KK 11	214, 286	
	60	VHV 20	142	VHV-M 20	142		KK 20	142	
	60	VHV 22	142	VHV-M 22	142		KK 22	70, 142	
	70	VHV 23	142	VHV-M 23	142		KK 23	70, 142	
	80	VHV 20	214, 286	VHV-M 20	214, 286		KK 20	214, 286	
	80	VHV 22	214, 286	VHV-M 22	214, 286		KK 22	214, 286	
	90	VHV 23	214, 286	VHV-M 23	214, 286		KK 23	214, 286	
	100	VHV 34	142	VHV-M 34	142		KK 34	70, 142	
	110	VHV 34	214, 286	VHV-M 34	214, 286		KK 34	214, 286	
	120	VHV 35	142	VHV-M 35	142		KK 35	70, 142	
	130	VHV 35	214, 286	VHV-M 35	214, 286		KK 35	214, 286	
	130	VHV 46	142	VHV-M 46	142		KK 46	70, 142	
	130	-	-	-	-		KK 58	70	
	140	-	-	-	-		KK 46	214, 286	
	140	-	-	-	-		KK 58	142	
150	-	-	-	-		KK 58	214, 286		

Horizontal design of VONARIS, VONARIS-M and KONTEC

Radiator placement

Placement behind a screen

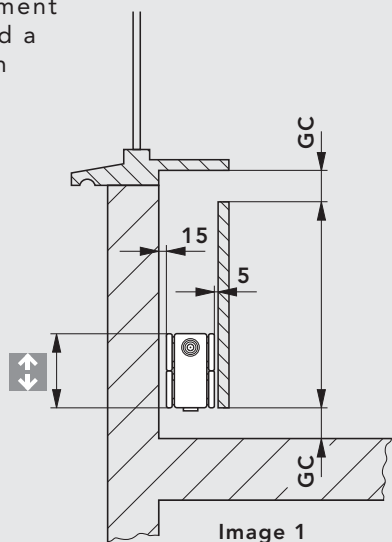

Image 1

Placement behind a desk

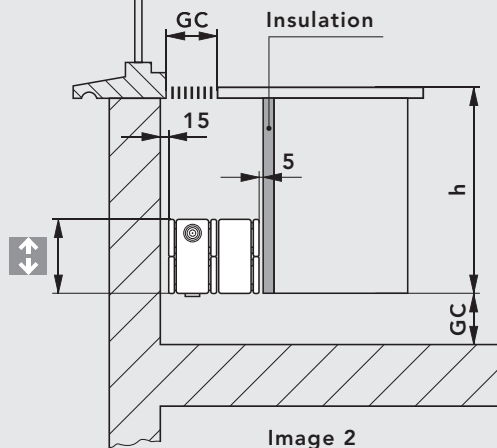

Image 2

Schematic diagram

Note:

Screens and desks should be movable so that the radiators and conduits can be cleaned.

Percentage increase of the radiator's heat emission due to the chimney effect, as illustrated with the placement in picture 1 and picture 2.

h [mm]	Percentage increase of the heat emission			
	OH 70 mm	OH 142 mm	OH 214 mm	OH 286 mm
150	14	-	-	-
200	20	8	-	-
250	26	12	2	-
300	30	15	6	-
350	33	19	9	3
400	36	22	12	6
450	39	25	15	9
500	41	28	17	11
600	46	32	21	14
700	50	35	24	18
800	-	38	27	21

Horizontal design of VONARIS, VONARIS-M and KONTEC

Placement of the radiators in regard to floor conduits

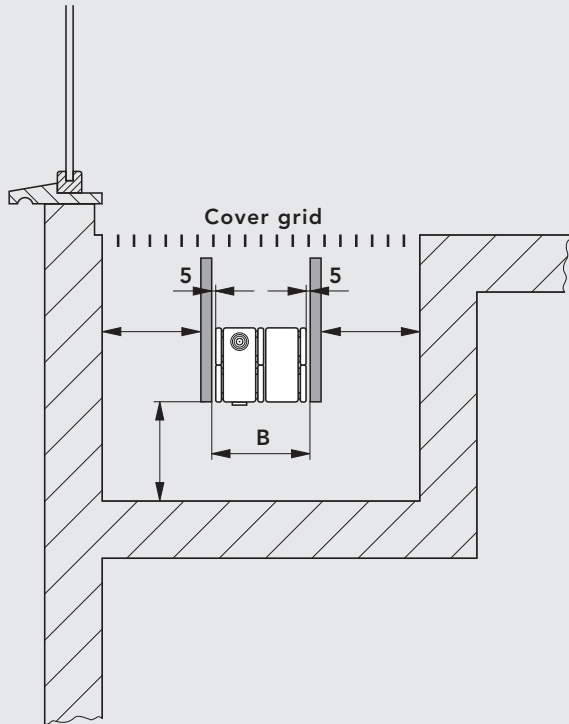

$B = \text{Overall radiator depth} + 10 \text{ mm}$
 $C \geq B$

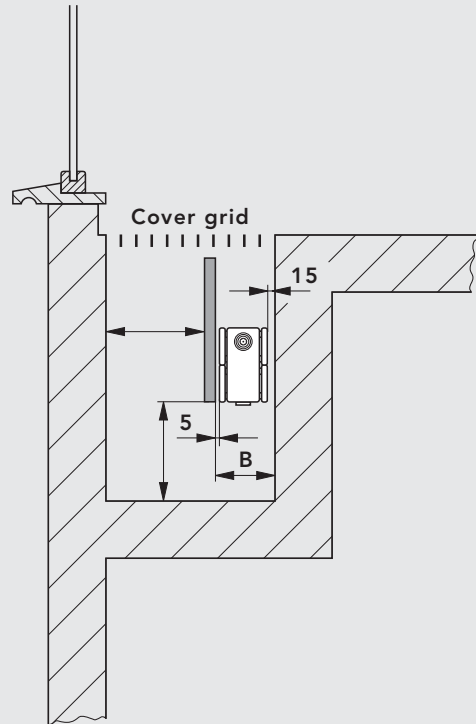

$B = \text{Overall radiator depth} + 20 \text{ mm}$
 $C \geq B$

Schematic diagram

The screening between the radiator surfaces and conduit walls must be made of heat-insulating materials (e. g.: timber, plastics etc.).

Take care that the lower edge of the screening corresponds to the lower edge of the radiator. The top edge of the screening should be fitted as near to the floor conduit cover as possible.

The cover grids of the floor conduit should be designed in a way that the open cross-sectional area amounts to at least 60 %.

We recommend to use cover grids that can easily be taken off in order to facilitate the cleaning of the floor conduit.

The heat emission of radiators installed in floor conduits (subsurface heating) is reduced at about 20 %, compared with the values given in the heat output index.

VONARIS solitary finished radiator										
Item	Number	Description								
		<p>VONARIS solitary finished radiator</p> <p>VONARIS the solitary finished radiator in a resistance-welding design, available as:</p> <p>Horizontal design, with 1 to 4 layers of steel rectangular water-flow pipes arranged one-behind-the-other, each layer consisting of from 2 to 11 pipes arranged one-above-the-other.</p> <p>Standard design: rectangular steel pipes 70 x 11 x 1.5 mm High pressure design: rectangular steel pipes 70 x 11 x 2.0 mm</p> <p>VVO-design: models in the horizontal design and up to an overall height of 286 mm are also available with a rear-welded heat reflector (no water-flow). The VHV 20 model and the VHV 22 model (overall heights 358 to 646 mm) may have a heat reflector fitted subsequently.</p> <p>Vertical design: with 1 or 2 layers of steel rectangular water-flow pipes, arranged one-behind-the-other, each layer consisting of from 3 to 12 steel pipes, arranged side-by-side.</p> <p>Standard design: rectangular steel pipes 70 x 11 x 1.5 mm High pressure design: rectangular steel pipes 70 x 11 x 2.0 mm</p> <p>A 2 mm space between the heating pipes guarantees additional resistance to corrosion.</p> <p>Top-quality electrophoretic undercoat, conforming to DIN 55900 part 1, stoved at 165° C; finished with electrostatic powder coating, conforming to DIN 55900 part 2, in RAL 9016 (on request, and at a supplementary charge, a range of RAL and sanitary ware colours can be offered); stoved at an object temperature of 180° C; equipped with a built-in valve set, suitable for either double-pipe or single-pipe operation, using a one-pipe manifold, with a factory-fitted cartridge valve (already installed) and protective cap.</p> <p>VONARIS solitary finished radiators will normally be delivered with side panels. The horizontal design is also equipped with a top cover. VONARIS solitary finished radiators, are not delivered with brackets as standard (exception: VHV 11, overall height 358 to 790 mm, does include brackets). For the vertical design, brackets are included.</p> <p>The VONARIS solitary finished radiator comes with a drain plug and a pivoting vent plug (with the vertical design, a dummy plug too), all of them factory-sealed.</p> <p>VONARIS solitary finished radiators comply with the former BAGUV regulations, performance conforming to DIN EN 442; triple packed (cardboard packaging, edge protection shrink foil).</p> <p>Connections (horizontal design): 2 x external thread G 3/4", bottom right (by special order, bottom left). Types VHV 20, VHV 22, VHV 34, and VHV 46 are reversible and so can be connected either at bottom right or at bottom left. Connections (vertical design): 2 x external thread G 3/4", bottom right (by special order, bottom left).</p>								
		<table border="0"> <tr> <td>Model:</td> <td>Pressure [bar]:</td> </tr> <tr> <td>Overall height [mm]:</td> <td>Number:</td> </tr> <tr> <td>Overall length [mm]:</td> <td>Colour:</td> </tr> <tr> <td>Radiator power [Watts]:</td> <td>Connections: (bottom right or bottom left)</td> </tr> </table>	Model:	Pressure [bar]:	Overall height [mm]:	Number:	Overall length [mm]:	Colour:	Radiator power [Watts]:	Connections: (bottom right or bottom left)
Model:	Pressure [bar]:									
Overall height [mm]:	Number:									
Overall length [mm]:	Colour:									
Radiator power [Watts]:	Connections: (bottom right or bottom left)									
		<p>Heat Reflector</p> <p>Consists of from 5 to 8 (exception OH 646: has got 9) layers of steel rectangular pipes (no water flow) arranged one-above-the-other; primed and coated in RAL 9016 (on request, and at a supplementary charge, a range of RAL and sanitary ware colours can be offered); equipped with 8 push-in brackets, 8 stabilising brackets, 4 Z-brackets, for installing the heat reflector at the horizontal design; suitable for types VHV 20 (OH 358 to 574 mm) and VHV 22 (OH 358 to 646 mm); packaging: cardboard packaging and shrink foil.</p>								

VONARIS central connection radiator

Item	Number	Description												
		<p>VONARIS central connection radiator</p> <p>VONARIS central connection radiator in a resistance-welding design, available as:</p> <p>Horizontal design, with 1 to 4 layers of steel rectangular water-flow pipes arranged one-behind-the-other, each layer consisting of from 2 to 11 pipes arranged one-above-the-other.</p> <p>Standard design: rectangular steel pipes 70 x 11 x 1.5 mm High pressure design: rectangular steel pipes 70 x 11 x 2.0 mm</p> <p>Vertical design: with 1 or 2 layers of steel rectangular water-flow pipes, arranged one-behind-the-other, each layer consisting of from 3 to 12 steel pipes, arranged side-by-side.</p> <p>Standard design: rectangular steel pipes 70 x 11 x 1.5 mm High pressure design: rectangular steel pipes 70 x 11 x 2.0 mm</p> <p>A 2 mm space between the heating pipes guarantees additional resistance to corrosion.</p> <p>Top-quality electrophoretic undercoat, conforming to DIN 55900 part 1, stoved at 165° C; finished with electrostatic powder coating, conforming to DIN 55900 part 2, in RAL 9016 (on request, and at a supplementary charge, a range of RAL and sanitary ware colours can be offered); stoved at an object temperature of 180° C; horizontal design equipped with a built-in valve set, suitable for either double-pipe or single-pipe operation, using a one-pipe manifold, with a factory-fitted cartridge valve (already installed) and protective cap. Vertical design with enclosed connection set suitable for single-pipe or double-pipe operation, and for angled or through-flow connection; comes with a built-in cartridge valve and a covering cap for the fitting in the corresponding radiator colour. VONARIS central-connection radiators are usually delivered with side panels. The horizontal design also comes equipped with a top cover. With the horizontal design, brackets are not included as a matter of course (exception: VHV-M 11 – overall height 358 to 790 mm, does include brackets). For the vertical design, brackets are included.</p> <p>The VONARIS central connection radiator comes with a drain plug and a pivoting vent plug (with the vertical design, two dummy plugs too), all of them factory-sealed.</p> <p>VONARIS central connection radiators comply with the former BAGUV regulations, performance conforming to DIN EN 442; triple packed (cardboard packaging, edge protection and shrink foil).</p> <p>Connections (horizontal design): 2 x external thread G 3/4", bottom centre of the radiator. Types VHV-M 20, VHV-M 22, VHV-M 34, and VHV-M 46 and without brackets are reversible and so can be connected thus that the valve is placed either on the right or left. Connections (vertical design): 2 x external thread G 3/4", bottom centre of the radiator</p>												
		<table border="0"> <tr> <td>Model:</td> <td>Colour:</td> </tr> <tr> <td>Overall height [mm]:</td> <td>Horizontal design:</td> </tr> <tr> <td>Overall length [mm]:</td> <td>Valve on the right or left:</td> </tr> <tr> <td>Radiator power [Watts]:</td> <td>Vertical design:</td> </tr> <tr> <td>Pressure [bar]:</td> <td>Connection set:</td> </tr> <tr> <td>Number:</td> <td> ZE Double-pipe operation – angled design ZD Double-pipe operation – through-flow design EE Single-pipe operation – angled design ED Single-pipe operation – through-flow design </td> </tr> </table>	Model:	Colour:	Overall height [mm]:	Horizontal design:	Overall length [mm]:	Valve on the right or left:	Radiator power [Watts]:	Vertical design:	Pressure [bar]:	Connection set:	Number:	ZE Double-pipe operation – angled design ZD Double-pipe operation – through-flow design EE Single-pipe operation – angled design ED Single-pipe operation – through-flow design
Model:	Colour:													
Overall height [mm]:	Horizontal design:													
Overall length [mm]:	Valve on the right or left:													
Radiator power [Watts]:	Vertical design:													
Pressure [bar]:	Connection set:													
Number:	ZE Double-pipe operation – angled design ZD Double-pipe operation – through-flow design EE Single-pipe operation – angled design ED Single-pipe operation – through-flow design													

KONTEC convectors and heating panels										
Item	Number	Description								
		<p>KONTEC convectors and heating panels</p> <p>KONTEC convectors and heating panels in a resistance-welding design, available as:</p> <p>Horizontal design, with either 1 to 5 layers of steel rectangular water-flow pipes arranged one-behind-the-other (for convectors), or 1 or 2 such layers (for horizontal heating panels). In each layer, the convectors have between one and four pipes arranged one-above-the-other; the horizontal heating panels have from 5 to 11 pipes.</p> <p>Standard design: rectangular steel pipes 70 x 11 x 1.5 mm High pressure design: rectangular steel pipes 70 x 11 x 2.0 mm</p> <p>WVO design: KONTEC convectors are also available with a welded heat reflector (no water-flow).</p> <p>Heat reflector for horizontal heating panels Consists of from 5 to 8 (exception OH 646: has got 9) layers of steel rectangular pipes (no water flow) arranged one-above-the-other; primed and coated in RAL 9016 (on request, and at a supplementary charge, a range of RAL and sanitary ware colours can be offered); equipped with 8 push-in brackets, 8 stabilising brackets, 4 Z-brackets, for installing the heat reflector at the horizontal design; suitable for types KH 20 (OH 358 to 574 mm) and KH 22 (OH 358 to 646 mm); packaging: cardboard packaging and shrink foil.</p> <p>The vertical design consists of 1 or 2 layers of steel rectangular water-flow pipes, arranged one-behind-the-other, with 2 to 12 steel pipes, arranged side-by-side.</p> <p>Standard design: rectangular steel pipes 70 x 11 x 1.5 mm High pressure design: rectangular steel pipes 70 x 11 x 2.0 mm</p> <p>A 2 mm space between the heating pipes guarantees additional resistance to corrosion.</p> <p>Top-quality electrophoretic undercoat, conforming to DIN 55900 part 1, stoved at 165° C; finished with electrostatic powder coating, conforming to DIN 55900 part 2, in RAL 9016 (on request, and at a supplementary charge, a range of RAL and sanitary ware colours can be offered); stoved at an object temperature of 180° C. KONTEC convectors and heating panels will normally be delivered with side panels. The horizontal design is also equipped with a top cover. Both the horizontal and vertical designs of the heating panels are normally be delivered with brackets.</p> <p>The KONTEC convector and heating panel comes with a drain plug and a pivoting vent plug (exception: with a bottom-only, opposite-end connection, a dummy plug instead of a drain plug), all of them factory-sealed.</p> <p>KONTEC convectors and heating panels comply with the former BAGUV regulations, performance conforming to DIN EN 442; triple packed (cardboard packaging, edge protection and shrink foil). Connections: 2 x internal thread G 1/2", according to the customer's specifications.</p>								
		<table border="0"> <tr> <td>Model:</td> <td>Pressure [bar]:</td> </tr> <tr> <td>Overall height [mm]:</td> <td>Number:</td> </tr> <tr> <td>Overall length [mm]:</td> <td>Colour:</td> </tr> <tr> <td>Radiator power [Watt]:</td> <td>Connections:</td> </tr> </table>	Model:	Pressure [bar]:	Overall height [mm]:	Number:	Overall length [mm]:	Colour:	Radiator power [Watt]:	Connections:
Model:	Pressure [bar]:									
Overall height [mm]:	Number:									
Overall length [mm]:	Colour:									
Radiator power [Watt]:	Connections:									

Guide table for the selection and number of required fastening systems for VONARIS solitary finished radiators

Guide for the selection and number of required **stand consoles** for types VHV and VHV-S (WVO design), up to an overall height of 286 mm

Stand consoles for the horizontal design, up to OH 286 mm

Radiator model	VHV 11		VHV 20		VHV 22		VHV-S 22		VHV 23	
	up to 2000	from 2200	up to 2000	from 2200	up to 2000	from 2200	up to 2000	from 2200	up to 2000	from 2200
 Overall length [mm]										
SK 10 for finished floors	2	3								
SK 11 for unfinished floors	2	3								
SK 12 for finished floors			2	3	2	3			2	3
SK 13 for unfinished floors			2	3	2	3			2	3
SK 14 for finished floors							2	3		
SK 15 for unfinished floors							2	3		

Radiator model	VHV 34		VHV-S 34		VHV 35		VHV 46		VHV-S 47	
	up to 2000	from 2200	up to 2000	from 2200	up to 2000	from 2200	up to 2000	from 2200	up to 2000	from 2200
 Overall length [mm]										
SK 14 for finished floors	2	3	2	3	2	3				
SK 15 for unfinished floors	2	3	2	3	2	3				
SK 16 for finished floors							2	3		
SK 17 for unfinished floors							2	3		
SK 18 for finished floors									2	3
SK 19 for unfinished floors									2	3

Guide for the selection and number of required **stand consoles** for types VHV 11, VHV 20 and VHV 22



Stand consoles suitable for the horizontal design with or without a heat reflector, for types VHV 11, VHV 20 and VHV 22, with an overall height of 358, 430, 502, 574 and 646 mm



Radiator model	VHV 11		VHV 20		VHV 22	
	up to 2000	from 2200	up to 2000	from 2200	up to 2000	from 2200
 Overall length [mm]						
SK 22			2			
SK 22				3		
SK 23	2				2	
SK 23		3				3



Guide table for the selection and number of required fastening systems for VONARIS solitary finished radiators

Guide for the selection and number of required **wall consoles** for types VHV, up to an overall height of 286 mm

Wall consoles for the horizontal design, up to OH 286 mm

Radiator model		VHV 11		VHV 20		VHV 22		VHV 23	
Wall console model		WK 10		WK 10		WK 10		WK 11	
	Overall length [mm]	between 500 and 2000	between 2200 and 4000	between 500 and 2000	between 2200 and 4000	between 500 and 2000	between 2200 and 4000	between 500 and 2000	between 2200 and 4000
Overall height 	142			2	3	2	3	2	3
	214	2	3	2	3	2	3	2	3
	[mm] 286	2	3	2	3	2	3	2	3

Radiator model		VHV 34		VHV 35		VHV 35		VHV 35	
Wall console model		WK 11		WK 12		WK 12		WK 12	
	Overall length [mm]	between 500 and 2000	between 2200 and 4000	between 500 and 2000	between 2200 and 4000	between 500 and 1800	between 2000 and 2600	between 2800 and 3600	between 3800 and 4000
Overall height 	142	2	3	2	3				
	214	2	3	2	3				
	[mm] 286	2	3			2	3	4	5

Radiator model		VHV 46		VHV 46		VHV 46		VHV 46	
Wall console model		WK 12		WK 12		WK 12		WK 12	
	Overall length [mm]	between 500 and 2000	between 2200 and 3000	between 500 and 1800	between 2000 and 2800	3000	between 500 and 1400	between 1600 and 2200	between 2400 and 2800
Overall height 	142	2	3						
	214			2	3	4			
	[mm] 286					5	2	3	4

Guide table for the selection and number of required fastening systems for VONARIS solitary finished radiators

 Guide for the selection and number of required **VONOMAT wall consoles** for types VHV 11 and VHV 23

VONOMAT wall consoles for the overall heights 214, 286, 430, 502, 574, 646 and 790 mm, with brackets

Radiator model		VHV 11		VHV 23	
Overall height [mm]	Overall length [mm]	up to 2000	from 2200	up to 2000	from 2200
	Set of 2 for 214, 286	1		1	
	Set of 3 for 214, 286		1		1
	Set of 2 for 358, 430, 502	1			
	Set of 3 for 358, 430, 502		1		
	Set of 2 for 574, 646, 790	1			
	Set of 3 for 574, 646, 790		1		

 Guide for the selection and number of required **VONOFIX rapid installation consoles** for types VHV 20, VHV 22 and VHV 34

VONOFIX rapid installation consoles for overall heights of 214, 286, 358, 430, 502, 574, 646 and 790 mm

Radiator model		VHV 20		VHV 22		VHV 34	
Overall height [mm]	Overall length [mm]	up to 2000	from 2200 with foot console	up to 2000	from 2200 with foot console	up to 2000	from 2200 with foot console
	VONOFIX 1 (set for 214)	1	1	1	1	1	1
	VONOFIX 2 (set for 286)	1	1	1	1	1	1
	VONOFIX 2 (set for 358)	1	1	1	1		
	VONOFIX 3 (set for 430)	1	1	1	1		
	VONOFIX 3 (set for 502)	1	1	1	1		
	VONOFIX 4 (set for 574)	1	1	1	1		
	VONOFIX 4 (set for 646)	1	1	1	1		
	VONOFIX 5 (set for 790)	1	1	1	1		

 Guide for the selection and number of required **wall mounting brackets** for types VSV 10, VSV 11, VSV 20 and VSV 21

Wall mounting brackets for the vertical design

Radiator model		VSV 10		VSV 11		VSV 20		VSV 21	
Overall length [mm]	Overall length [mm]	214	from 286	214	from 286	214	from 286	214	from 286
	WA 10, set	1		1		1		1	
	WA 11, set of 2		1		1		1		1

Guide table for the selection and number of required fastening systems for VONARIS central connection radiators



Guide for the selection and number of required **stand consoles** for types VHV-M up to an overall height of 286 mm.



Stand consoles for the horizontal design, up to OH 286 mm



Radiator model		VHV-M 22		VHV-M 34		VHV-M 46	
 Overall length [mm]		up to 2000	from 2200	up to 2000	from 2200	up to 2000	from 2200
SK 12 for finished floors		2	3				
SK 13 for unfinished floors		2	3				
SK 14 for finished floors				2	3		
SK 15 for unfinished floors				2	3		
SK 16 for finished floors						2	3
SK 17 for unfinished floors						2	3

Guide for the selection and number of required **VONOMAT wall consoles** for types VHV-M 11, VHV-M 20, VHV-M 22 and VHV-M 34

VONOMAT wall consoles for overall heights of 214, 286, 358, 430, 502, 574, 646 and 790 mm, with brackets

Wall console model		VONOMAT 300					
Radiator model		VHV-M 11		VHV-M 22		VHV-M 34	
 Overall length [mm]		up to 2000	from 2200	up to 2000	from 2200	up to 2000	from 2200
Overall height  [mm]	Set of 2 for 214, 286			1		1	
	Set of 3 for 214, 286				1		1
	Set of 2 for 358	1					
	Set of 3 for 358		1				

Wall console model		VONOMAT 400					
Radiator model		VHV-M 11		VHV-M 20		VHV-M 22	
 Overall length [mm]		up to 2000	from 2200	up to 2000	from 2200	up to 2000	from 2200
Overall height  [mm]	Set of 2 for 358, 430, 502			1		1	
	Set of 3 for 358, 430, 502				1		1
	Set of 2 for 430, 502, 574	1					
	Set of 3 for 430, 502, 574		1				

Wall console model		VONOMAT 600					
Radiator model		VHV-M 11		VHV-M 20		VHV-M 22	
 Overall length [mm]		up to 2000	from 2200	up to 2000	from 2200	up to 2000	from 2200
Overall height  [mm]	Set of 2 for 574, 646, 790			1		1	
	Set of 3 for 574, 646, 790				1		1
	Set of 2 for 646, 790	1					
	Set of 3 for 646, 790		1				

Guide table for the selection and number of required fastening systems for VONARIS central connection radiators

 Guide for the selection and number of required **VONOFIX rapid installation consoles** for types VHV-M 20, VHV-M 22 and VHV-M 34

VONOFIX rapid installation consoles for overall heights of 214, 286, 358, 430, 502, 574, 646 and 790 mm

Radiator model		VHV-M 20		VHV-M 22		VHV-M 34	
Overall height [mm]	Overall length [mm]	up to 2000	from 2200 with foot console	up to 2000	from 2200 with foot console	up to 2000	from 2200 with foot console
	VONOFIX 1 (set for 214)			1	1	1	1
	VONOFIX 2 (set for 286)			1	1	1	1
	VONOFIX 2 (set for 358)	1	1	1	1		
	VONOFIX 3 (set for 430)	1	1	1	1		
	VONOFIX 3 (set for 502)	1	1	1	1		
	VONOFIX 4 (set for 574)	1	1	1	1		
	VONOFIX 4 (set for 646)	1	1	1	1		
	VONOFIX 5 (set for 790)	1	1	1	1		

 Guide for the selection and number of required **wall fastening brackets** for types VSV-M 10, VSV-M 11, VSV-M 20 and VSV-M 21

Wall fastening brackets for the vertical design

Radiator model		VSV-M 10*		VSV-M 11*		VSV-M 20		VSV-M 21	
Overall length [mm]	Overall length [mm]	214	from 286	214	from 286	214	from 286	214	from 286
	WA 10, set	1		1		1		1	
	WA 11, set of 2		1		1		1		1

***Note:** when installing the VSV-M 10 and VSV-M 11 models with an angled connection set (ZE, EE), please use the appropriate drill consoles and angled fishplates to ensure that the required distance from the wall is maintained.

Guide table for the selection and number of required fastening systems for KONTEC convectors

Guide for the selection and number of required **stand consoles** for KONTEC convectors, types KK and KK-S (WVO design)

Stand consoles for convectors without brackets

Radiator model	KK 11		KK 20		KK 22		KK-S 22	
 Overall length [mm]	up to 2000	from 2200	up to 2000	from 2200	up to 2000	from 2200	up to 2000	from 2200
SK 10 for finished floors	2	3						
SK 11 for unfinished floors	2	3						
SK 12 for finished floors			2	3	2	3		
SK 13 for unfinished floors			2	3	2	3		
SK 14 for finished floors							2	3
SK 15 for unfinished floors							2	3

Radiator model	KK 23		KK 34		KK-S 34		KK 35	
 Overall length [mm]	up to 2000	from 2200	up to 2000	from 2200	up to 2000	from 2200	up to 2000	from 2200
SK 12 for finished floors	2	3						
SK 13 for unfinished floors	2	3						
SK 14 for finished floors			2	3	2	3	2	3
SK 15 for unfinished floors			2	3	2	3	2	3

Radiator model	KK 46		KK-S 47		KK 58			
 Overall length [mm]	up to 2000	from 2200	up to 2000	from 2200	up to 2000	from 2200		
SK 16 for finished floors	2	3						
SK 17 for unfinished floors	2	3						
SK 18 for finished floors			2	3	2	3		
SK 19 for unfinished floors			2	3	2	3		

Guide for the selection and number of required **VONOMAT** wall consoles for KONTEC convectors, type KK



VONOMAT wall consoles for convectors with an overall height of 214 and 286, with brackets



Radiator model	KK 11		KK 20		KK 22		KK 23		KK 34	
 Overall length [mm]	up to 2000	from 2200	up to 2000	from 2200	up to 2000	from 2200	up to 2000	from 2200	up to 2000	from 2200
Set of 2	1		1		1		1		1	
Set of 3		1		1		1		1		1



Guide table for the selection and number of required fastening systems for KONTEC convectors



Guide for the selection and number of required wall consoles for KONTEC convectors, type KK

Wall consoles for convectors without brackets

Radiator model		KK 11		KK 20		KK 22		KK 23		KK 34	
Wall console model		WK 10		WK 10		WK 10		WK 11		WK 11	
 Overall length [mm]		between 500 and 2000	between 2200 and 4000	between 500 and 2000	between 2200 and 4000	between 500 and 2000	between 2200 and 4000	between 500 and 2000	between 2200 and 4000	between 500 and 2000	between 2200 and 4000
Overall height  [mm]	70			2	3	2	3	2	3	2	3
	142			2	3	2	3	2	3	2	3
	214	2	3	2	3	2	3	2	3	2	3
	286	2	3	2	3	2	3	2	3	2	3

Radiator model		KK 35		KK 35		KK 35		KK 46		KK 46	
Wall console model		WK 12		WK 12		WK 12		WK 12		WK 12	
 Overall length [mm]		between 500 and 2000	between 2200 and 4000	between 500 and 1800	between 2000 and 2600	between 2800 and 3600	between 3800 and 4000	between 500 and 2000	between 2200 and 3000	between 500 and 1900	between 2000 and 2800
Overall height  [mm]	70	2	3					2	3		
	142	2	3					2	3		
	214	2	3							2	3
	286			2	3	4	5				

Radiator model		KK 46		KK 46		KK 58		KK 58		KK 58	
Wall console model		WK 12		WK 12		WK 13		WK 13		WK 13	
 Overall length [mm]		3000	between 500 and 1400	between 1500 and 2200	between 2400 and 2800	between 500 and 2000	2200	between 500 and 1700	between 1800 and 2200	between 500 and 1100	between 1200 and 1700
Overall height  [mm]	70					2	3				
	142							2	3		
	214	4								2	3
	286	5	2	3	4		6				

Radiator model		KK 58		KK 58		KK 58	
Wall console model		WK 13		WK 13		WK 13	
 Overall length [mm]		between 1800 and 2200	between 500 and 800	between 900 and 1300	between 1400 and 1700	between 1800 and 2000	
Overall height  [mm]	70						
	142						
	214	4					
	286		2	3	4	5	

Guide table for the selection and number of required fastening systems for KONTEC convectors

Guide for the selection and number of required fastening systems for KONTEC heating panels

Stand consoles, suitable for horizontal heating panels with or without heat reflector, for types KH 11, KH 20 and KH 22

Radiator model	KH 11		KH 20		KH 22	
 Overall length [mm]	up to 2000	from 2200	up to 2000	from 2200	up to 2000	from 2200
SK 22			2			
SK 22				3		
SK 23	2				2	
SK 23		3				3

 Guide for the selection and number of required **wall fastening brackets** for vertical KONTEC heating panels, type KS

Wall fastening brackets for vertical heating panels

Radiator model	KS 10		KS 11		KS 20		KS 21	
 Overall length [mm]	up to 214	from 286	up to 214	from 286	up to 214	from 286	up to 214	from 286
WA 10, Set	1		1		1		1	
WA 11, Set of 2		1		1		1		1

 Guide for the selection and number of required **Vonomat wall consoles** for horizontal KONTEC heating panels, type KH

Vonomat wall console, suitable for all horizontal heating panels with brackets

Radiator model	KH 10		KH 11		KH 20		KH 22	
 Overall length [mm]	up to 2000	from 2200	up to 2000	from 2200	up to 2000	from 2200	up to 2000	from 2200
Set of 2	1		1		1		1	
Set of 3		1		1		1		1

Heat reflector for the horizontal design of types VHV 20*, VHV 22, KH 20* and KH 22

Overall length ↔ [mm]	Overall height ↑↓ [mm]				
	358	430	502	574	646
500					
600					
700					
800					
900					
1000					
1100					
1200					
1300					
1400					
1600					
1800					
2000					
2200					
2400					
2600					
2800					
3000					
3200					
3400					
3600					
3800					
4000					

*Note: with types 20 the heat reflector is available only up to an overall height of 574 mm.

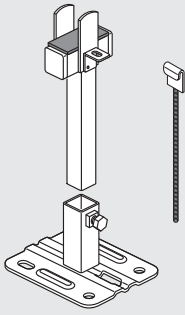
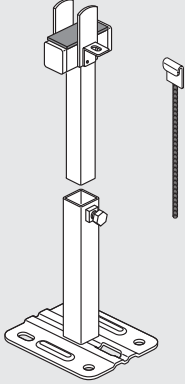
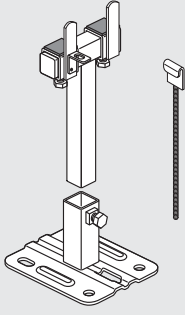
Image	Order number	Article description
	<p>H00F1AF01A</p>	<p>Stand console SK 10, for finished floors</p> <p>VONARIS model: VHV 11, with an OH of 214 and 286 mm</p> <p>KONTEC model: KK 11</p> <p>consisting of: 1 piece of stand base (80 mm), 1 piece of stand top (175 mm), with a soundproof support and 1 piece of integrated connection locking device, zinc-plated and coated in RAL 9016**</p>
	<p>H00F1AR01A</p>	<p>Stand console SK 11, for unfinished floors</p> <p>VONARIS model: VHV 11, with an OH of 214 and 286 mm</p> <p>KONTEC model: KK 11</p> <p>consisting of: 1 piece of stand base (175 mm), 1 piece of stand top (200 mm), with a soundproof support and 1 piece of integrated connection locking device zinc-plated and coated in RAL 9016**</p>
	<p>H00F1AF02A</p>	<p>Stand console SK 12, for finished floors</p> <p>VONARIS model: VHV 20, VHV 22 and VHV 23, with an OH of 142, 214 and 186 mm</p> <p>VONARIS-M model: VHV-M 22, with OH of 214 and 286 mm</p> <p>KONTEC model: KK 20, KK 22, KK 23</p> <p>consisting of: 1 piece of stand base (80 mm), 1 piece of stand top (175 mm), with 2 soundproof supports and 1 piece of integrated connection locking device, zinc-plated and coated in RAL 9016**</p>

Note: for the recommended number of required consoles see pages 119, 122 and 124.

**Also available in colour design at an extra charge (exception: positioners)

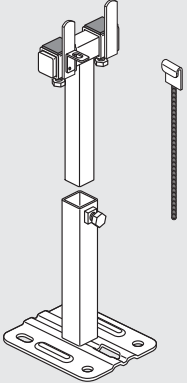
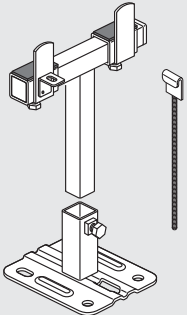
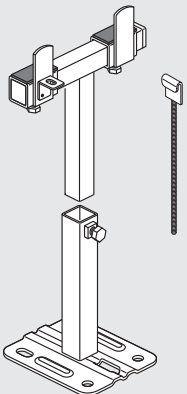
Image	Order number	Article description
	<p>H00F1AR02A</p>	<p>Stand console SK 13, for unfinished floors</p> <p>VONARIS model: VHV 20, VHV 22 and VHV 23, with an OH of 142, 214 and 286 mm</p> <p>VONARIS-M model: VHV-M 22, with OH of 214 and 286 mm</p> <p>KONTEC model: KK 20, KK 22, KK 23</p> <p>1 piece of stand base (175 mm), 1 piece of stand top (200 mm), with 2 soundproof supports and 1 piece of integrated connection locking device, zinc-plated and coated in RAL 9016**</p>
	<p>H00F1AF03A</p>	<p>Stand console SK 14, for finished floors</p> <p>VONARIS model: VHV-S 22, VHV 34, VHV-S 34 and VHV 35, with an OH of 142, 214 and 286 mm</p> <p>VONARIS-M model: VHV-M 34 with an OH of 142, 214 and 286 mm</p> <p>KONTEC model: KK-S 22, KK 34, KK-S 34, KK 35</p> <p>consisting of: 1 piece of stand base (80 mm), 1 piece of stand top (175 mm), with 2 soundproof supports and 1 piece of integrated connection locking device, zinc-plated and coated in RAL 9016**</p>
	<p>H00F1AR03A</p>	<p>Stand console SK 15, for unfinished floors</p> <p>VONARIS model: VHV-S 22, VHV 34, VHV-S 34, and VHV 35 with an OH of 142, 214 and 286 mm</p> <p>VONARIS-M model: VHV-M 34 with OH of 142, 214 and 286 mm</p> <p>KONTEC model: KK-S 22, KK 34, KK-S 34, KK 35</p> <p>consisting of: 1 piece of stand base (175 mm), 1 piece of stand top (200 mm), with 2 soundproof supports and 1 piece of integrated connection locking device, zinc-plated and coated in RAL 9016**</p>

Note: for the recommended number of required consoles see pages 119, 122 and 124.

**Also available in colour design at an extra charge (exception: positioners)

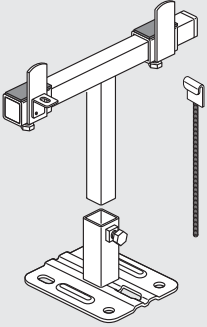
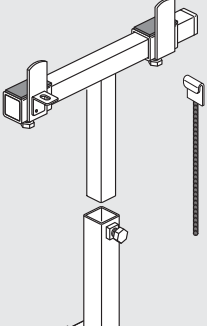
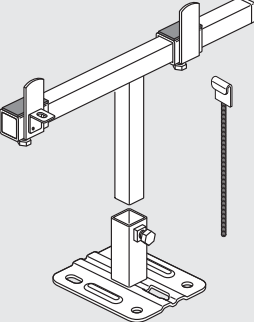
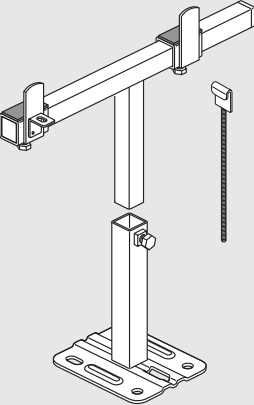
Image	Order number	Article description
	H00F1AF04A	<p>Stand console SK 16, for finished floors</p> <p>VONARIS model: VHV 46 with an OH of 142, 214 and 286 mm</p> <p>VONARIS-M model: VHV-M 46 with an OH of 142, 214 and 286 mm</p> <p>KONTEC model: KK 46</p> <p>Consisting of: 1 piece of stand base (80 mm), 1 piece of stand top (175 mm), with a soundproof support and 1 piece of integrated connection locking device, zinc-plated and coated in RAL 9016**</p>
	H00F1AR04A	<p>Stand console SK 17, for unfinished floors</p> <p>VONARIS model: VHV 46 with an OH of 142, 214 and 286 mm</p> <p>VONARIS-M model: VHV-M 46 with an OH of 142, 214 and 286 mm</p> <p>KONTEC model: KK 46</p> <p>Consisting of: 1 piece of stand base (175 mm), 1 piece of stand top (200 mm), with a soundproof support and 1 piece of integrated connection locking device, zinc-plated and coated in RAL 9016**</p>
	H00F1AF05A	<p>Stand console SK 18, for finished floors</p> <p>VONARIS model: VHV-S 47</p> <p>KONTEC model: KK-S 47, KK 58</p> <p>Consisting of: 1 piece of stand base (80 mm), 1 piece of stand top (175 mm), with 2 soundproof supports and 1 piece of integrated connection locking device, zinc-plated and coated in RAL 9016**</p>
	H00F1AR05A	<p>Stand console SK 19, for unfinished floors</p> <p>VONARIS model: VHV-S 47</p> <p>KONTEC model: KK-S 47, KK 58</p> <p>Consisting of: 1 piece of stand base (175 mm), 1 piece of stand top (200 mm), with a soundproof support and 1 piece of integrated connection locking device, zinc-plated and coated in RAL 9016**</p>





Note: for the recommended number of required consoles see pages 119, 122 and 124.

**Also available in colour design at an extra charge (exception: positioners)

Image	Order number	Article description
	H00F1AA00A	<p>Covering surround ASK 10 Covering made of plastic in white, suitable for the base plate of the stand consoles SK 10, SK 12, SK 14, SK 16 and SK 18</p>
	H00SKMS00A	<p>Installation template VHV-M for stand consoles, types 22–46, for SK 12 to SK 17</p>
	H00SKVL00A	<p>Extension spacers for stand consoles, 1 VHV-M set Overall length from between 1600 and 2400 mm, right and left</p>
	H00MW0120A	<p>Installation frames for VONARIS, 3/4" 120 mm design, incl. BYPASS</p>
	H00MW0200A	<p>Installation frames for VONARIS, 3/4" 200 mm design, incl. BYPASS</p>

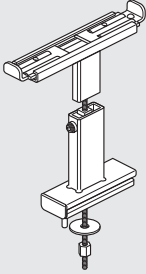
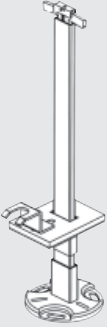
Note: for the recommended number of required consoles see pages 119, 122, 124 and 126.

**Also available in colour design at an extra charge (exception: positioners)

Image	Order number	Article description
	H00T1A000A	<p>Window sill support FBT 20 Window sill support for subsequent installation with:</p> <p>VONARIS model: VHV/VHV-S 22-47 up to an overall height of 286 mm</p> <p>VONARIS-M model: VHV-M 22-46 up to an overall height of 286 mm</p> <p>KONTEC model: KK/KK-S 22-58 up to an overall height of 286 mm</p> <p>Consisting of: 1 piece of window sill base, window sill top, as well as 1 piece of thread rod with washer and nut, coated in RAL 9016**</p>
	H00F1AS00A	<p>Stand Console SK 22 Stand console for the horizontal design without brackets, and with or without heat reflector, for OH of 358, 430, 502 and 574 mm, finished in white</p> <p>VONARIS model: VHV 20</p> <p>KONTEC model: KH 20</p> <p>Consisting of: 1 piece of base plate and 1 piece of standpipe, soundproof, with a connection locking device</p>
	FBSSP32ZB	<p>Stand Console SK 23 Stand console for the horizontal design without brackets, and with or without heat reflector, for OH of 358, 430, 502, 574 and 646 mm, finished in white</p> <p>VONARIS model: VHV 11 and VHV 22</p> <p>KONTEC model: KH 11 and KH 22</p> <p>Consisting of: 1 piece of base plate and 1 piece of standpipe, soundproof, with a connection locking device</p>
	FBSDE31ZA	<p>Standpipe cladding, white for stand consoles SK 22 and SK 23 (subsequent installation possible)</p>
	FBSFR31ZA	<p>Covering surround ASK 11 made of plastic in white, for stand consoles SK 22 and SK 23 (subsequent installation possible)</p>

Note: for the recommended number of required consoles see pages 119, 120, 125 and 126.

**Also available in colour design at an extra charge (exception: positioners)

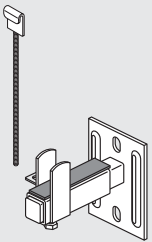
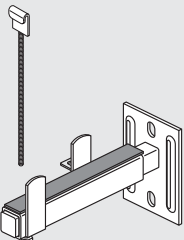
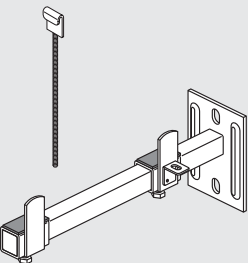
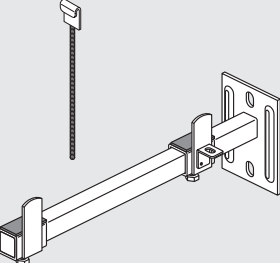
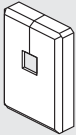
Image	Order number	Article description
	<p>H00W1A001A</p>	<p>Wall console WK 10</p> <p>VONARIS model: VHV 11 with OH 214 and 286 mm, VHV 20, VHV 22, with OH 142, 214 and 286 mm</p> <p>KONTEC model: KK 11, KK 20 and KK 22</p> <p>Consisting of: 1 piece of wall console, 1 piece of adjustable retaining plate with soundproof support, and 1 piece of connection locking device, zinc-plated and coated in RAL 9016**</p>
	<p>H00W1A002A</p>	<p>Wall console WK 11</p> <p>VONARIS model: VHV 23 and VHV 34</p> <p>KONTEC model: KK 23 and KK 34</p> <p>Consisting of: 1 piece of wall console, 1 piece of adjustable retaining plate with soundproof support, and 1 piece of connection locking device, zinc-plated and coated in RAL 9016**</p>
	<p>H00W1A003A</p>	<p>Wall console WK 12</p> <p>VONARIS model: VHV 35 and VHV 46</p> <p>KONTEC model: KK 35 and KK 46</p> <p>Consisting of: 1 piece of wall console, 1 piece of adjustable retaining plate with 2 soundproof supports, and 1 piece of connection locking device, zinc-plated and coated in RAL 9016**</p>
	<p>H00W1A004A</p>	<p>Wall console WK 13</p> <p>KONTEC model: KK 58</p> <p>Consisting of: 1 piece of wall console, 1 piece of adjustable retaining plate with 2 soundproof supports, and 1 piece of connection locking device, zinc-plated and coated in RAL 9016**</p>
	<p>H00W1AA00A</p>	<p>Covering surround AWK</p> <p>Covering made of plastic in white, suitable for the wall panel of the wall consoles WK 10 to WK 13</p>

Note: for the recommended number of required consoles see pages 120 and 125.

**Also available in colour design at an extra charge (exception: positioners)

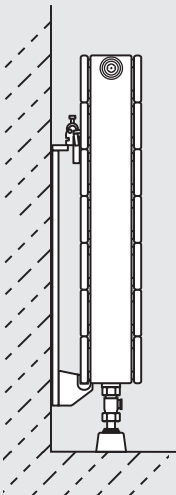
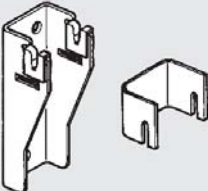
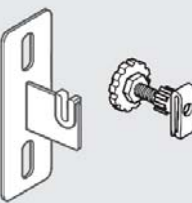
Image	Order number	Article description
 	<p>H00R2A001A H00R3A001A</p> <p>H00R2A002A H00R3A002A</p> <p>H00R2A003A H00R3A003A</p> <p>H00R2A004A H00R3A004A</p> <p>H00R2A005A H00R3A005A</p>	<p>VONOFIX rapid installation console, suitable for</p> <p>VONARIS model: for types ,VHV 20 and VHV 22, with OH between 214 and 790 mm, and VHV 34, with OH 214 and 286 mm</p> <p>VONARIS-M model: for types VHV-M 20, with OH between 358 and 790 mm, VHV-M 22, with OH between 214 and 790 mm, and VHV-M 34, with OH 214 and 286 mm</p> <p>Consisting of: 2 pieces of wall consoles (zinc-plated), with sound-absorbing filters, 2 pieces of stabilising brackets, 2 pieces of push-in brackets, screws and dowels. (From an overall length of 2200 mm onwards, additionally 1 piece of foot console).</p> <p>VONOFIX 1-rapid installation console for OH 214 mm up to Overall length 2000 mm from Overall length 2200 mm</p> <p>VONOFIX 2-rapid installation console for OH 286 und 358 mm up to Overall length 2000 mm from Overall length 2200 mm</p> <p>VONOFIX 3-rapid installation console for OH 430 und 502 mm up to Overall length 2000 mm from Overall length 2200 mm</p> <p>VONOFIX 4-rapid installation console for OH 574 und 646 mm up to Overall length 2000 mm from Overall length 2200 mm</p> <p>VONOFIX 5-rapid installation console for OH 790 mm up to Overall length 2000 mm from Overall length 2200 mm</p>
	<p>H00U2A000A</p>	<p>Wall mounting brackets WA 10 for vertical heating panels with OL 142 and 214 mm; exception: VSV-M 10 and VSV-M 11, with angular connection set, and VSV 10, VSV 11, KS 10 and KS 11, with angular connection (please note: wall clearance!).</p> <p>Consisting of: 1 piece of console, spacers, screws and dowels, soundproof</p>
	<p>H00W2A000A</p>	<p>Wall mounting brackets WA 11 for vertical heating panels with OL from 286 mm; exception: VSV-M 10 and VSV-M 11, with angular connection set, and VSV 10, VSV 11, KS 10 and KS 11, with angular connection (please note: wall clearance!).</p> <p>Consisting of: 2 pieces of consoles each, spacers, screws and dowels, soundproof</p>

Note: for the recommended number of required consoles see pages 121, 123 and 126.

**Also available in colour design at an extra charge (exception: positioners)

Sanitary-ware colours.

RAL colours.

Metallic colours.

The colours shown here are not binding. Chromatic aberrations are possible due to typographic reasons. Additional colours are available on request! Technical information subject to change.



VOGEL&NOOT

Rettig Austria GmbH Vogel und Noot Straße 4, 8661 Wartberg, Austria
T: +43 3858 601-0, F: -1298, marketing@vogelundnoot.com, www.vogelundnoot.com



heatingthrough**innovation.**